



TECHNICAL MANUAL

VERSION 12

12: ROOF TERRACES AND BALCONIES

12.

Roof Terraces and Balconies

Contents

Functional Requirements

12.1 Roof Terraces

12.2 Balconies

Limitations of Functional Requirements

1. These Functional Requirements do not and will not apply to create any Policy liability for any remedial works carried out by the Contractor or otherwise, nor to any materials used in those remedial works.
2. The guidance provided in this Section, is guidance that provides a suggested solution to meeting the Functional Requirements. If an alternative solution is selected, then this must still meet the Functional Requirements.
3. Means of escape, passive and active systems are not covered by the Warranty.

Workmanship

1. A flat roof membrane manufacturer's approved installer must be used for all roof terrace coverings.
2. Roof terrace membranes will be required to be weather and waterproof and, tested at completion where stipulated in the guidance.
3. All workmanship must be within the tolerance requirements set out in this Technical Manual.
4. All work is to be carried out by a technically competent person in a workmanlike manner.
5. Concreting shall not take place during cold weather periods where the working temperature is below 2°C or where ground conditions are frozen.

Materials

1. All materials should be stored, installed and protected correctly in a manner that will not cause damage or deterioration of the product.
2. All materials, products and building systems shall be appropriately tested and approved for their intended purpose.
3. All load bearing structural elements providing support to the Home will have a service life of not less than 60 years, unless specifically agreed otherwise with us. All other parts of the Home will have a lesser durability and need planned maintenance, repair or replacement during that reduced period.
4. Whilst there is and can be no Policy responsibility and/or liability for any roof covering, window/ door or 'decorative external cladding' (i.e. cladding which is decorative only and the substrate wall provides the main weather proof barrier) to achieve a performance service life of 60 years or less, such elements shall be designed and constructed so they have an intended service life of not less than where stipulated within this Manual.
5. Timber should be adequately treated or finished to resist insect attacks and be suitable for the position used within the structure. All timber treatment should be in accordance with relevant British Standards and Codes of Practice.
6. Timber used in the building to provide support to the structure must be appropriately seasoned to prevent excessive shrinkage and movement.
7. All materials should be suitable for the relative exposure of the building in accordance with the relevant British Standards.

Design

1. For Warranty purposes, cold deck roof terraces are not acceptable.
2. Roof terrace and balcony structures and coverings, shall be designed and constructed so that they:
 - a. Are structurally sound;
 - b. Satisfactorily resist the passage of moisture due to rain and snow to the inside of the building, and to materials which might be adversely affected by such moisture;
 - c. Have an adequate thermal performance where applicable;
 - d. Adequately discharge rainwater to a suitable outfall.
3. In addition to point 2d: shall, unless specifically agreed otherwise with the Warranty provider, comply with the requirements of BS 6229 and be designed to have a minimum finished fall of 1 in 80.
4. Roof terraces and balconies must have appropriate guarding meeting the requirements of Building Regulations.
5. The following additional elements shall be supported by structural calculations designed by an Engineer:
 - a. Structural elements outside the parameters of Building Regulations.
 - b. Specialist structural works.
 - c. Reinforced concrete elements.
 - d. Precast structural elements.
 - e. Any engineered beams/posts manufactured off-site.
6. Damp proofing works should prevent any external moisture passing into the internal environment of the building.
7. Projects consisting of non-standard/modern methods of construction must be supported with evidence of valid independent third party product conformity certification before an offer of Warranty is provided. These types of constructions must be declared before commencement.

12.

Roof Terraces and Balconies

12.1 Roof Terraces

Provision of information

A full set of design drawings and specifications shall be made available to the Warranty Provider and all other interested parties prior to the associated works starting on site. This may include:

1. A full set of detailed drawings including:
 - a) Plan showing direction of falls and position of outlets and overflows.
 - b) Sections showing roof terrace build up and how falls are to be created. Sectional details should show all components to be used in roof terrace build up (insulation type and thickness, Vapour control layer, waterproofing membrane/ layers etc.).
 - c) Site specific detailing for all junctions, outlets, threshold and upstand interfaces with the façade.
 - d) Details of the provision of pedestrian surface support structure (where appropriate).
 - e) Details of the provision of guarding including parapet walls and balustrading used as guarding. This should be designed in accordance with BS EN 1991-1-1 to resist horizontal loading and as required by the Building Regulations.
 - f) Details of all fire stopping which should include specification and a detailed location layout drawing showing positioning of all fire stopping.
2. Third party accreditation for the waterproofing membrane/layer.
3. Details of all fixings, their frequency and fixing method, including those for insulation and surfacing. Fixing methodology should be supported by appropriate wind uplift calculations.
4. Outline of method and plan for testing the integrity of the waterproofing layer.
5. In all circumstances, the roof terrace membrane system will need to be installed by an approved contractor who is recognized by the manufacturer as competent. Evidence of the manufacturer's approval of the contractor to install their products should be provided to the Warranty Surveyor.

The Warranty Surveyor, at their discretion, may also request supporting information that demonstrates suitability for use of any materials or systems contained within the above.

Definitions

For the purposes of this Technical Guidance, the following definitions shall apply:

Roof terraces: an accessible amenity above ground level which is exterior to and with direct access from a building which forms part of a roof or forms the entire roof to other occupied parts of a building. This section provides specific advice and requirements in respect of roof terraces.

Condensation: process whereby water is deposited from air containing water vapour when its temperature drops to or below dew point.

Filter layer: construction material (usually a geotextile) that substantially reduces the transfer of mineral and organic material to the insulation in an inverted warm deck roof.

Flat roof: a roof having a pitch no greater than 10° to the horizontal.

Insulation cricket: wedge of shallow-fall insulation material, designed to divert the flow of rainwater on a roof.

Interstitial condensation: condensation occurring within or between the layers of the building envelope.

Protection layer: construction material (usually a geotextile all rigid board) that isolates another construction material from mechanical damage.

Separation layer: construction material (usually a geotextile) that separates two construction materials that are not chemically compatible.

Structural deck: continuous layer of the construction (comprising concrete, profiled metal or timber panel) supported by the building structure and which supports the roof system.

Thermal bridge: part of a roof of lower thermal resistance than its surrounding elements, which may result in localised cold surfaces on which condensation, mould growth or staining may occur.

Air vapour control layer (AVCL): construction material (usually a membrane) that substantially reduces the movement of water vapour through the roof system.

Water flow reducing layer (WFRL): construction material (usually a sheet membrane) that substantially reduces the transfer of rain water to the insulation in an inverted warm deck roof.

Structure general

The roof terrace structure should be designed for strength and stiffness in accordance with the Code of Practice for the relevant structural material used.

Relevant structural material on roof terrace structure strength and stiffness should be assessed in accordance with BS EN 1992-1-1, BS EN 1993-1-1, BS EN 1994-1-1, BS EN 1995-1-1, BS EN 1999-1-1 and their UK National Annexes.

A roof deck may be classed as air permeable and likely to allow internal air pressures to impinge on the roof system from below. Wind uplift pressure exerted on the underside of any layer of the construction (which is substantially air-impermeable), such as the vapour control layer or the waterproof layer. This should be resisted by adequate mechanical or fully bonded connections between the air impermeable layer and the deck. Particular consideration should be provided at corners of buildings or where funnelling may occur due to adjacent buildings or topography.

The roof terrace design should take account of possible differential movements within the slab/deck and at junctions with supporting structure, parapets, kerbs and upstands.

Note: Such movements might be caused by movement of the structural frame or by changes of temperature and moisture content.

Loading

Statutory requirement

The design for loading should comply with the current Building Regulations.

The terrace shall be constructed so that the combined dead, imposed and wind loads are sustained and transmitted by it to the ground safely, and without causing such deflection or deformation of any part of the building, or such movement of the ground, as to impair the stability of any part of another building.

Dead and imposed loads upon a roof terrace should be assessed in accordance with BS EN 1991-1-1 + UK National Annex; taking due consideration of any added surfacing, paving slabs, gravel or other materials contributing to the final loading. Snow loads should be assessed in accordance with BS EN 1991-1-3 + UK National Annex. Wind loads should be assessed in accordance with BS EN 1991-1-4:2005 + A1:2010 + UK National Annex.

The roof terrace structure should be constructed so that it has sufficient structural load transfer to the wall, allowing the roof terrace structure to act as a horizontal diaphragm capable of transferring the wind forces to buttressing elements of the building.

Resistance to imposed loads

At the earliest possible stage, the designer should define the range of potential imposed loads for which the balcony is to be designed such as planters, storage and public access. In the absence of such a performance requirement the loading limits of the balcony should be defined.

Allowances for the prevention of wind uplift

The resistance to wind uplift of the waterproof covering and finishes on a flat roof terrace should be assessed in accordance with BS 8217 and BS EN 16002. The designer must consider the dead weight of materials above the weatherproof surface layer and their method of attachment to the slab or deck and prevent wind uplift in the design.

It is necessary that the design for the roof terrace build up has adequate provision to resist wind uplift by being adequately anchored to the main structure. In all situations a calculation of wind uplift at each zone of the roof terrace to BS EN 1991-1-4 should be undertaken by a suitably competent person. Wind load acting on a terrace will be affected significantly by the design of the perimeter, geometry and finishes on the elevations of the building. Any relevant changes to materials in the build-up of the walls or floors is likely to necessitate a review of the calculated input to ensure that the assumptions initially held remain valid.

Balustrade fixings

Fixings for balustrades must be carefully designed to ensure appropriate fixings are robust and do not comprise the waterproof membrane. Any penetration through the waterproof membrane are to be sealed correctly in accordance product manufacturer's recommendations.

Insulation

The insulation should be specified taking into account the roof type, having regard to its load-bearing capacity and, where relevant, its water absorption characteristics. Compressible materials cannot support imposed loads and are not suitable in warm deck roofs. Warm roofs require the use of rigid insulation, and should be suitably specified to support the any anticipated loads from trafficking across the roof. Insulation in an inverted roof should also have high resistance to water absorption, freeze/thaw cycling and be shielded from UV light.

Design

The principal thermal insulation is placed immediately below the roof terrace covering, resulting in the structural deck and support being at a temperature close to that of the interior of the building.

The design should ensure that:

- The waterproof membrane has sufficient resistance to temperature to suit the conditions created by a substrate of insulation.
- The insulation has sufficient mechanical characteristics to resist loading.
- The AVCL is provided by the deck or by a membrane placed above the deck.
- The structural deck is maintained at a temperature above that which could cause condensation to occur at this level during service.

Cold deck roof systems are not permitted on roof terraces that form part of the roof to other occupied parts of the building.

Warm deck

Waterproof membrane



Thermal insulation

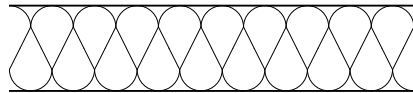

Air vapour control layer (if feasible)



Structural deck

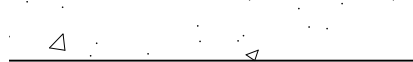

Warm deck roof terrace

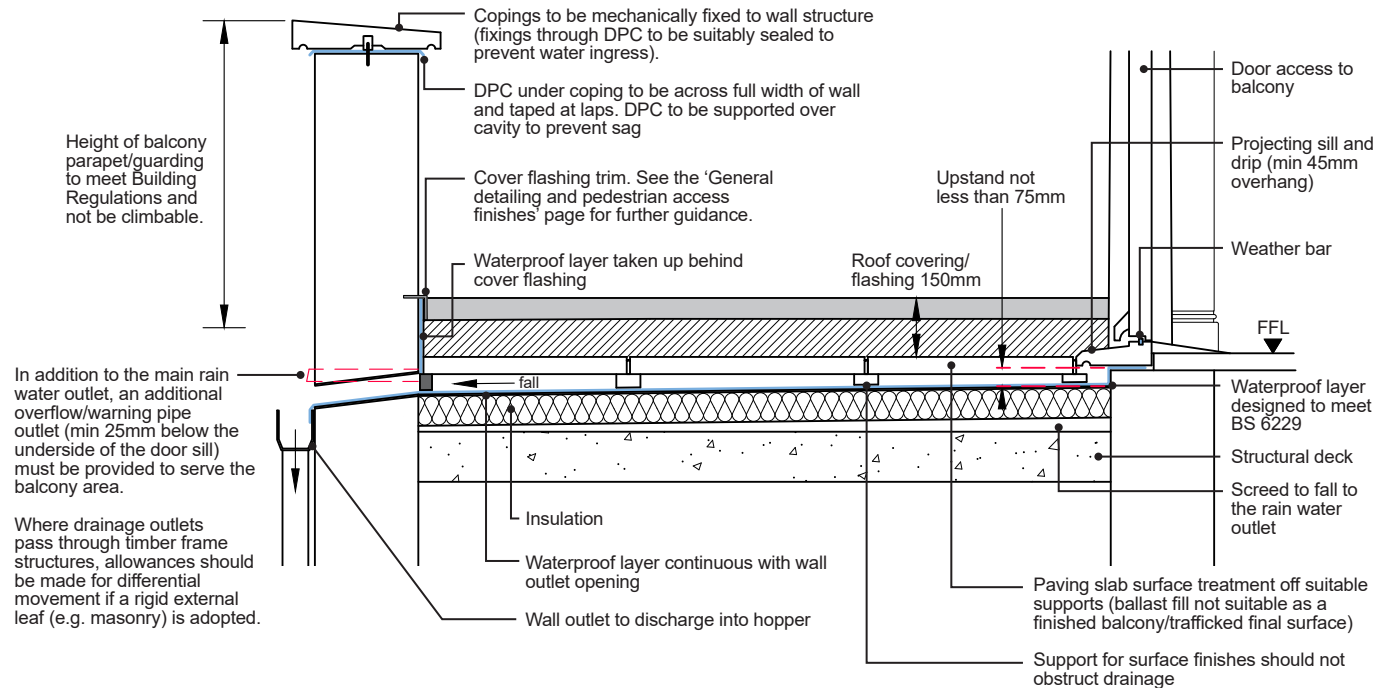

Notes

- Insulation above structural deck and waterproof layer to be suitable for exposure to moisture and of sufficient loading to compress the substrate and promote moisture migration to an outlet.
- Waterproof membrane must be laid to a fall - to a suitable outlet. All joints formed must be sealed in accordance with the manufacturer's requirements and not result in water being trapped/ponding.
- Membrane not to be laid in air temperatures less than 5°C. All membranes are to be fully bonded and a sample of peel tests should be undertaken as verification of workmanship.
- Where structural deck is constructed over accommodation below the design, construction should meet sound insulation requirements.
- Structural deck to be an engineered design for the loading/intended use which should be structurally stable over the lifespan of the building.
- A spreader plate or additional protection to any waterproof membrane will be required to protect the insulation under paving supports to spread loads to prevent sag and ponding.
- Where the penetration to form the outlet is made through the wall construction, which is constructed of steel frame care should be taken to prevent thermal bridging.
- Hopper construction should include a flashing apron and the hopper should be accessible for clearing debris on a regular basis.

Design

A variant of the warm deck roof terrace in which the principal thermal insulation is placed above the waterproof membrane, resulting in the waterproof membrane, structural deck and structural support being at a temperature close to that of the interior of the building. Generally, the principal insulation is secured by separate ballast (paving, gravel, or blue/green roof - minimum 80 kg/m²).

A filter membrane or WCM should be provided to control mineral and organic material passing into and below the insulation joints. A WCM is recommended because it will provide improved rain water run-off, which may allow for a reduced thickness of insulation and reduced loading of ballast. If a WCM is included, it is essential that the drainage design facilitates the rapid transfer of rain water across the product and to rain water outlets.

Cold deck roof systems are not permitted on terraces that form part of the roof to other occupied parts of the building. In these circumstances the selection of system type (warm deck or inverted warm deck) should be based upon the following criteria:

Inverted warm deck

Ballast

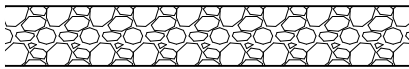

Filter layer or water control membrane

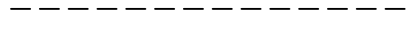

Thermal insulation

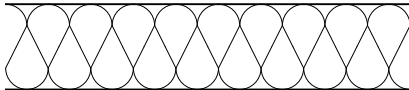

Waterproof membrane



Structural deck

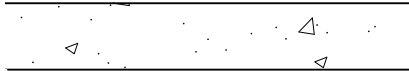

Inverted warm deck roof terrace

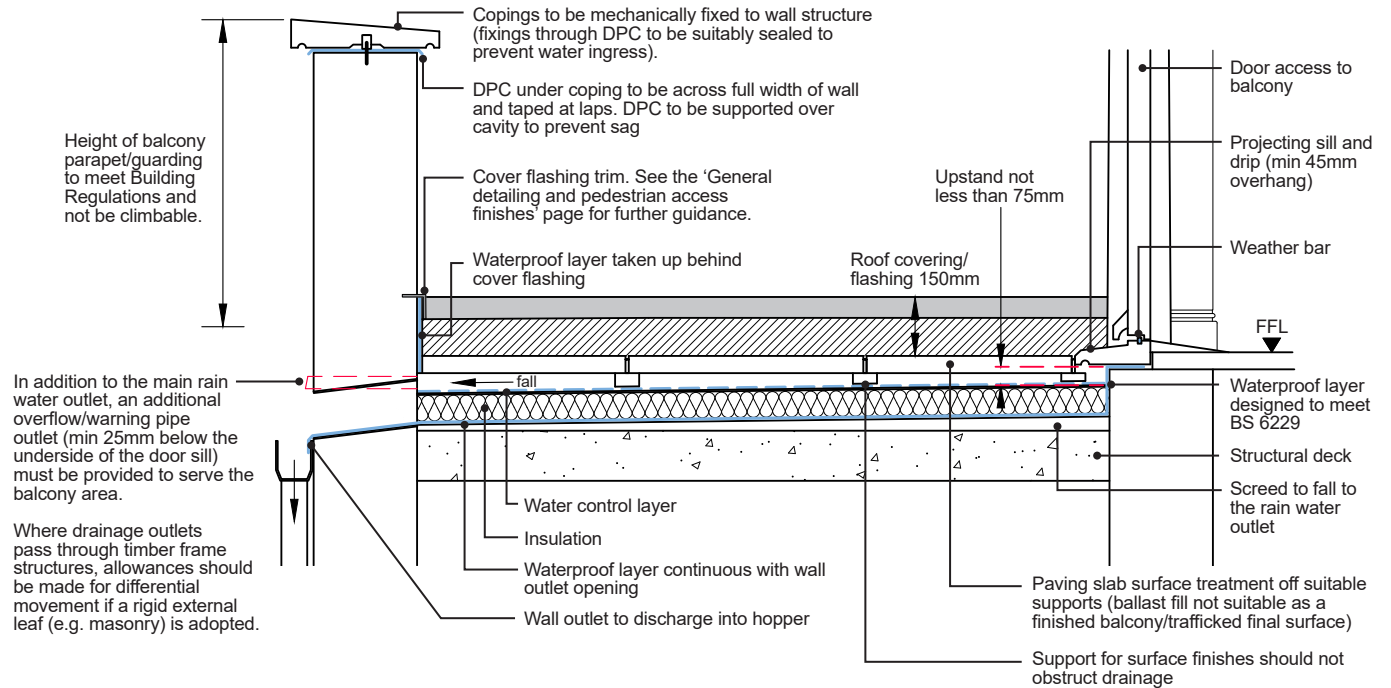

Notes

- Insulation above structural deck and waterproof layer to be suitable for exposure to moisture and of sufficient loading to compress the substrate and promote moisture migration to an outlet. Waterproof membrane must be laid to a fall - to a suitable outlet. All joints formed must be sealed in accordance with the manufacturer's requirements and not result in water being trapped/ponding.
- Membrane not to be laid in air temperatures less than 5°C. All membranes are to be fully bonded and a sample of peel tests should be undertaken as verification of workmanship.
- Where structural deck is constructed over accommodation below the design, construction should meet sound insulation requirements.
- Structural deck to be an engineered design for the loading/intended use which should be structurally stable over the lifespan of the building.
- A spreader plate or additional protection to any waterproof membrane will be required to protect the insulation under paving supports to spread loads to prevent sag and ponding.
- Where the penetration to form the outlet is made through the wall construction, which is constructed of steel frame care should be taken to prevent thermal bridging.
- Hopper construction should include a flashing apron and the hopper should be accessible for clearing debris on a regular basis.

Hybrid roof terraces

Many roofs combine the features of two or more of the roof types previously described. Examples include structural decks of high thermal resistance combined with additional insulation, and existing roofs to which thermal insulation is added. Once assessed in terms of their thermal and water vapour transmission characteristics, such roofs will generally fall into one of the categories described.

In some constructions, the waterproof membrane is placed between two layers of insulation, combining the properties of warm roof terrace and inverted warm roof terrace construction. This form of construction should be avoided wherever possible.

There is an increased risk of interstitial condensation with a hybrid roof and therefore, where these types of roof systems are used, a full condensation risk analysis should be carried out by the methods laid out in BS EN ISO 13788 and BS 5250. No interstitial condensation should occur in the model and where moisture is present and evaporates in the summer months an assessment of the potential degradation of the materials used as part of the build-up should occur so it can be expected that the lifespan and durability of the materials still meets the functional requirements of the Technical Manual.

Limitations of this guidance

The guidance for timber structures forming a roof terrace is limited to any building with a height of no more than three storeys above the lowest adjacent external ground level.

Structure

The design of the terrace should be designed by an Engineer in accordance with BS EN 1995-1: Eurocode 5 design of timber structures. General. Common rules and rules for buildings.

The structural deck should be designed by an Engineer. It is important to ensure that the structural deck is installed and fixed in accordance with the Engineer's design.

If joists are spanning intermediate beams it is important that the joists are fixed to these beams. This must be carried out in accordance with the Engineers specification.

The Designer must establish the intended loadings expected on the roof terrace including loads from finishing surfaces such as paving slabs and/ or ballast as well as any potential planting.

The likely maximum potential deflection of the deck should be confirmed to ensure a minimum 1:80 as built fall is maintained. The designer should consider the impact of long term creep in the design of all joists and the impact on falls this may have in the long term. Secondary joists that span intermediate horizontal primary beams must be mechanically fixed in accordance with the Engineers specification. Fasteners are to be sufficiently protected from corrosion and specified according to the external exposure and environment.

For further guidance on structural design requirements and loadings, please refer to the 'Roof Terraces and Balconies – Roof Terraces: Definitions and general principles' section.

Timber grading and treatment

All structural timber used should be stress graded. All such timber must be stamped as either 'DRY' or 'KD' (Kiln Dried). The use of ungraded, or 'green', timber is not acceptable.

Preservative treatment of roof terrace timbers is normally only required under relevant standards and Codes of Practice, however in some instances may be considered good practice. Further information can be found in 'Appendix C - Materials, Products, and Building Systems'.

Lateral restraint of walls

Walls should be adequately restrained at floors, ceilings and verges in accordance with the relevant Building Regulations.

Restraint can be provided by:

- Lateral restraint straps.
- Restraint type joist hangers.
- Other forms of restraint proven by the Engineer.

Please refer to the 'External Walls' section for further guidance.

Typical warm deck construction

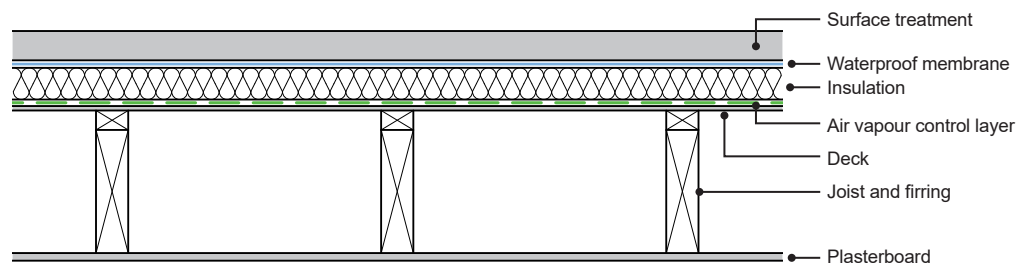

Typical inverted warm deck construction

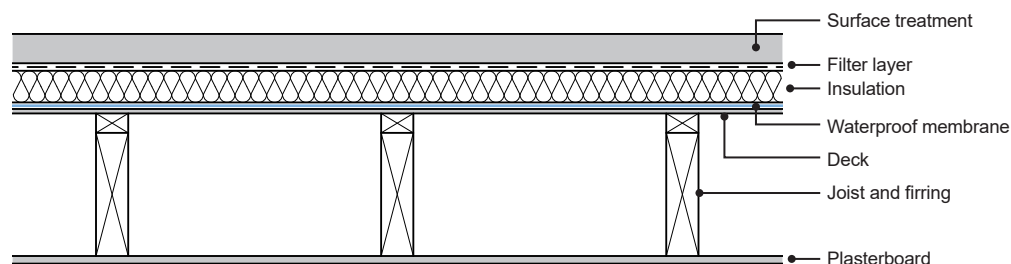

Typical warm deck construction

Note: Permanent waterproofing should not be installed until the moisture content of the deck is as per the membrane manufacturer's recommendations. Preparation of the receiving substrates should also be as per the membrane manufacturer's guidance.

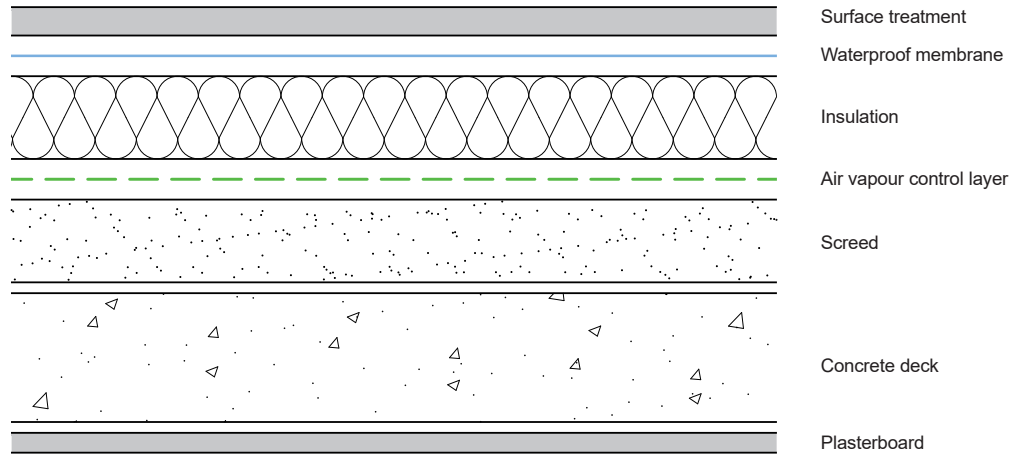

Typical inverted warm deck construction

Note: Permanent waterproofing should not be installed until the moisture content of the deck is as per the membrane manufacturer's recommendations. Preparation of the receiving substrates should also be as per the membrane manufacturer's guidance.

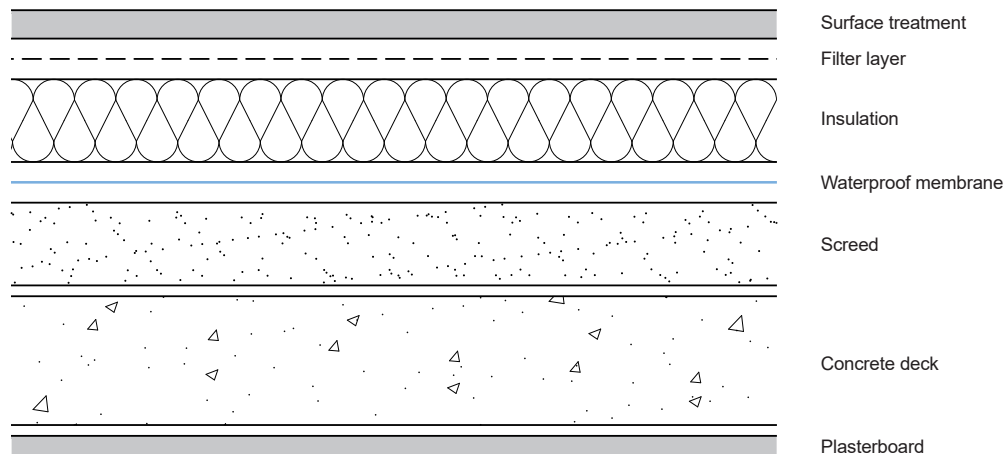

For in situ concrete decks it is important that:

- The form work is adequately and accurately constructed.
- The mix should be one that has relatively low shrinkage characteristics.
- The slab should be adequately protected until cured.

Pre cast concrete decks should:

- Have a minimum of 90mm bearing unless justified by the design.
- Be grouted in accordance with the design, and,
- Allowance for movement should be provided at abutments.

Structural deck

General

At the earliest practical stage, the likely deflection in the deck, and the tolerance in the level of its finish, should be confirmed, because this informs the design for drainage. If the deck is intended to receive mechanical fasteners for the attachment of roof system components such as insulation, or equipment such as fall-arrest line posts, its resistance to pull-out should also be confirmed to enable design for resistance to wind load.

Concrete

Precast concrete construction should be designed in accordance with BS 8110. Information on span capability and the installation requirements of precast panels can be obtained from manufacturer's. Information on the location of required movement joints should be obtained early in the design process as they have implications for drainage layout and detailing. Precast panels installed to a fall can provide a simple layout but without cross falls.

In-situ concrete construction should be designed in accordance with BS 8110. Concrete decks should be laid to falls wherever possible, concrete may be more difficult to lay to a fall, and it is common to create falls in the insulation (warm roofs only) or by using an additional screed. Information on compressive strength, resistance to point load and drying periods of wet screeds can be obtained from suppliers and relevant trade associations.

Where structural movement joints are required in large concrete decks, a clearly defined movement joint detail should be constructed to a design and with the materials that afford durability equivalent to that of the roof system.

In precast panel decks the locations of any anticipated differential movement e.g. at perimeter or abutment interfaces or between adjacent panels that are subject to differential loading, must be identified in order that stress is not transferred to the waterproof membrane.

Screeds

Screeds should be suitably specified for the anticipated loadings, further information can be found in 'Appendix C - Materials, Products, and Building Systems'. Moisture from the construction can become trapped in a roof if the waterproof layer is applied before a concrete slab or screed has had sufficient time to dry out. In situ concrete slabs and cementitious screeds contain large volumes of water which, if not allowed to dry out, can prevent adhesion of the waterproof layer. If bonding to the slab, it is advised that an adhesion test be carried out.

Lateral restraint of walls

Walls should be adequately restrained at floors, ceilings and verges in accordance with the relevant Building Regulations.

Restraint can be provided by:

- Lateral restraint straps.
- Restraint type joist hangers.
- Other forms of restraint proven by the Engineer.

Please refer to the 'External Walls' section for further guidance.

Typical warm deck construction

Falls can be created by firrings or tapered insulation.

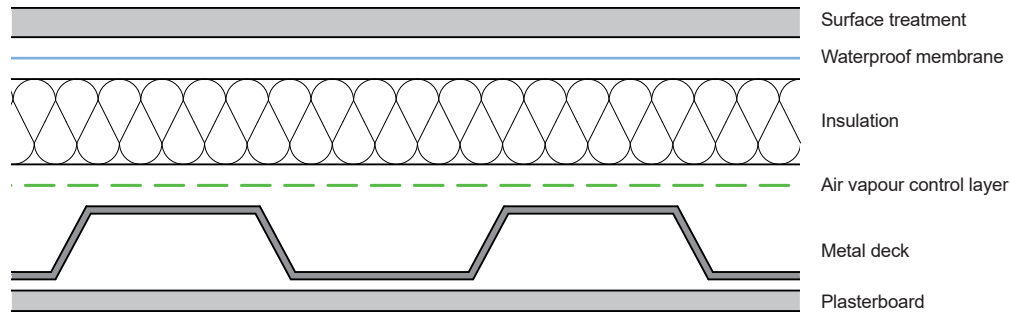
**Typical inverted warm deck construction**

Falls can be created by firrings or tapered insulation.

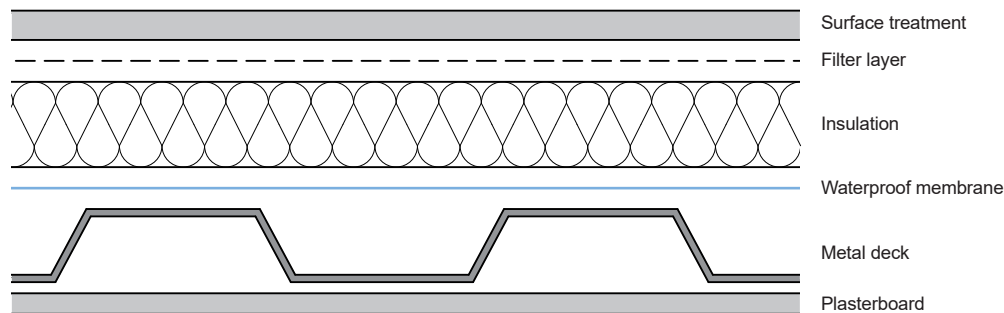
**Structural deck****General**

At the earliest practical stage, the likely deflection in the deck, and the tolerance in the level of its finish, should be confirmed, because this informs the design for drainage. If the deck is intended to receive mechanical fasteners for the attachment of roof system components such as insulation, or equipment such as fall-arrest line posts, its resistance to pull-out should also be confirmed to enable design for resistance to wind load.

Profiled metal (steel or aluminium)

Profiled metal decks should have a crown width at least 50% of the profile width. To provide a sound base for the insulation and waterproofing system, and to avoid reduced drainage performance, the mid-span deflection of the metal deck should not exceed 1/200 of the span under uniformly distributed design loads. When considering the deck profile and the necessity for side lap stitching and metal deck closures, reference should be made to the manufacturer's of the deck, insulation and waterproof membrane.

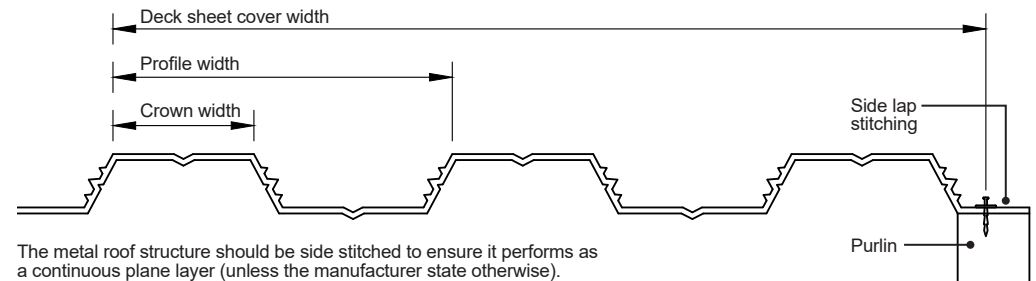
Profiled metal decks: critical dimensions

The metal roof structure should be side stitched to ensure it performs as a continuous plane layer (unless the manufacturer state otherwise).

Profiled metal decks should conform to the following standards:

- Galvanised steel: minimum recommended thickness 0.7mm to BS EN 10346 Fe E280G Z275. Typical gauge range 0.7mm-1.2mm.
- Plain aluminium: minimum recommended thickness 0.9mm to BS EN 485-2 AA3004 H34. Reference should also be made to BS EN 1396 as appropriate.

It is important that the deck have adequate provisions to resist wind uplift by being adequately anchored to the main structure.

Lateral restraint of walls

Walls should be adequately restrained at floors, ceilings and verges in accordance with the relevant Building Regulations.

Restraint can be provided by:

- Lateral restraint straps.
- Restraint type joist hangers.
- Other forms of restraint proven by the Engineer.

Please refer to the 'External Walls' section for further guidance.

Thermal performance

Design for thermal performance must comply with current relevant Building Regulations, as appropriate.

Thermal insulation

The thermal insulation should be selected with regard to the following minimum criteria:

- Thermal insulation components are to have third party product approval confirming suitability for use in proposed situation.
- Thermal resistance (and therefore thickness) to suit minimum clearances at details.
- Resistance to compression and point loads from surface finishes/supports.
- Compatibility with the AVCL and waterproof membrane.
- Compatibility with adhesives (if insulation or waterproof covering is adhered).
- Contribution to the external fire performance of the system.
- Acoustic properties: resistance to external sound is not currently regulated. However, there may be a need to consider attenuation from balconies.
- A spreader plate will be required to protect the insulation under paving supports to spread loads to prevent sag and ponding.

Note: The alternative of a separate acoustic attenuation layer should be considered where appropriate.

Thermal transmittance

Design for thermal transmittance should take account of the effect of thermal bridging within the roof field and at interfaces between the roof system and adjoining elements, such as parapet walls or abutments.

In particular, allowance should be made for the effect of:

- Thermal bridging by metal fasteners used to secure insulation and/or membrane. Thermal break telescopic tube fasteners are recommended to avoid this.
- Thermal bridging due to drainage of rain water or snow-melt through insulation in inverted roofs. The use of a WFRL beneath ballast to reduce thermal bridging is recommended.
- The locations of above average thermal transmittance at sumps, gutters or areas of minimum thickness of tapered insulation.

Manufacturer's of thermal insulation and WFRLs provide certification and calculations of the effects of thermal bridging by fasteners and drainage respectively. Further advice is available in Building Research Establishment BR 262 Thermal insulation: avoiding risks.

Installation of thermal insulation

The attachment of the thermal insulation should be designed to resist calculated wind load by a declared margin of safety. This includes consideration of dead loads required in all roof zones in ballasted warm roofs and inverted warm roofs.

Air permeability

Relevant contract drawings should define the position of the component - the air barrier - that determines resistance to air permeability. This may be achieved by an additional, purpose designed membrane or by an additional function of another component, such as the deck or waterproof membrane.

Control of condensation

Any provision required to control interstitial condensation within the roof should be determined to the calculation method defined by BS 5250, but with ambient conditions set in BS 6229. The calculated maximum accumulation of moisture within thermal insulation should not exceed 350g/m² and there shall be no net accumulation in any annual cycle.

Air vapour control layer (AVCL)

The AVCL should be selected with regard to the following minimum criteria:

- Ease with which it can be sealed at laps and at abutments to other elements.
- The method of attachment.
- Condensation risk, expressed as calculated vapour pressure based on notional conditions pertaining to the project building.
- Compatibility with the waterproof membrane and thermal insulation.

The following is a minimum recommended specification. The actual specification will depend on the level of vapour resistance required, based on calculation, and the type of deck.

The attachment of the AVCL should be designed to resist calculated wind load by a declared margin of safety. All laps should be sealed and the AVCL should be sealed to the adjoining element, which forms the continuation of the resistance to air permeability. The AVCL should be extended behind all thermal insulation, including insulation placed on vertical surfaces such as parapet walls. Where the roof system is penetrated by a detail such as a pipe or duct, a suitable method for providing continuous vapour control should be provided, and this method should be followed in practice.

Where a reinforced bitumen membrane AVCL is used, its installation should be in accordance with BS 8217.

Minimum recommended specification for AVCL for warm deck roofs

Roof system type	Deck type	AVCL	Attachment
Reinforced bitumen ⁽¹⁾ membrane	Profiled metal	S2P3 ⁽²⁾	Partial bond by 3G or approved proprietary alternative
	Concrete	S2P3	Fully bonded
	Timber panel	S2P3	Partial bond by 3G or approved proprietary alternative
High density polyethylene	All	200µ	Loose laid beneath mechanically fixed insulation
High density polyethylene and metal foil laminate	As per certification	Proprietary	Fully bonded to prepared substrate all as per manufacturer's instructions
Coated metal foil laminate - self-adhesive	As per certification	Proprietary	Fully bonded to prepared substrate all as per manufacturer's instructions

Notes:

- (1) Reinforced bitumen membranes: minimum recommended specification based on classification in BS 8747.
 (2) S and P are classifications 1-5 of Strength (tensile strength and elongation) and resistance to puncture (static and dynamic); the higher the rating, the higher the performance.

Falls and drainage statutory requirement

Design for drainage of the flat roof covering should comply with the current relevant Building Regulations.

British and industry standards

The requirements of BS 6229 should prevail in respect of balconies and roof terraces, whether or not they form part of the entire roof to occupied parts of a building, and irrespective of the type of waterproof membrane.

Wherever practical, balconies, terraces, and podium decks should be designed to fall away from the building elevation. If this is not practical for reasons of continuity of rainwater services, the falls should be arranged across the balcony, parallel to the elevation.

BS 6229 states that a minimum finished fall at any point of 1:80 (1.25%) should be achieved.

Since adjoining roof planes at 1:80 will meet at a mitre of less than 1:80, the intended finished fall at such intersections should be considered at an early stage.

Design falls should take account of any potential deflection and construction tolerances. In the absence of detailed calculations, this may necessitate design falls of twice the minimum finished falls (1:40 or 2.5%).

Cut-to-falls systems are often produced to a 1:60 (1.7%) fall or 1:40 (2.5%) fall. However the use of these systems does not remove the need to check that deck deflection and tolerance is overcome and that a resulting fall in the waterproof membrane of a minimum of 1:80 is achieved. Allowance for deflection is particularly important in designing inverted roofs where calculation of dead loading should be based upon the ballast type and depth to be used.

The manufacturers of certain waterproofing products have certification for their use in 'completely flat' or 'zero falls' applications. However, for the purposes of this standard, the design conditions of BS 6229 shall be assumed to prevail in all balcony/terrace situations.

Consideration should also be given to:

- The available upstand height at the high end of the falls. This may be a limiting factor on the length/size of the balcony/terrace area to be drained. If necessary additional rainwater outlets should be provided.
- Avoidance of ponding behind wide obstructions to the drained slope such as plant plinths or roof lights. Additional rainwater outlets and/or insulation crickets should be provided.
- Avoidance of gutters by designing with intersecting roof planes.
- Falls between rain water outlets along a perimeter.

Since the primary function of the roof is to exclude water, it is important to consider how best to direct this into the drainage system.

Ponding on membrane roofs must be avoided because:

- It encourages the deposit of dirt and leaves, which can be unsightly, may obstruct outlets and/or become a slip hazard.
- In the event of damage, the interior will suffer increased water ingress.
- The load may cause progressive deflection of the deck.
- Ice or algae may create a slip or wind hazard, particularly on walkways.

Independent research has shown that roofs with extensive ponding require increased maintenance input.

Waterproof coverings of all types are tested for water absorption and water tightness as part of third-party certification. However, the construction process, including the installation of components and the forming of seams, is clearly facilitated in dry, well-drained conditions.

Note: Rainwater outlets and downpipes can constitute thermal bridges which may increase the risk of localized condensation; an assessment might be required to determine whether insulated outlets are to be used.

Creation of falls

Roof falls may either be created during the construction of the deck or alternatively by using tapered insulation systems (warm deck systems only).

The creation of falls in the deck should always be attempted because it has the following advantages:

- There will be a consistent thermal environment across the roof.
- The AVCL will also be to a fall.

- If mechanical fasteners are to be used for the waterproof membrane, their length will be constant, which facilitates planning and installation.

Cementitious screeds provide a stable substrate to mitred and general falls of 1:80 and are recommended. Screeds should be in accordance with BS 8204. Lightweight screeds should be overlaid with a 1:6 (cement to sand) screed topping of a minimum 10mm thickness.

Tapered insulation schemes, suitable for warm deck roofs only, have the following advantages:

- It is possible to create effective drainage layouts to complex plan areas.
- Mitred falls can be created easily to direct rain water to single points where outlets are to be located.

Where falls are created by tapered insulation, the design should ensure that the average U-value and maximum U-value at any point, required by SBEM or SAP calculation, is achieved.

Where the roof finish is to include paving on supports, consideration should be given to the height difference created by the falls and spacing of rainwater outlets so that the maximum height of paving supports is not exceeded, the minimum height of upstands is not affected or trip hazards created. On large balconies and roof terraces it may be necessary to increase the number of outlets in order to reduce maximum roof zone depth.

Drainage

Drainage design should be based upon calculations in accordance with BS EN 12056 Part 3 given a design head of water (typically 30-35mm). Rain water outlet capacity should be taken from properly certificated information provided by manufacturer, and the resulting number and layout of outlets should allow for obstruction and drag due to any additional surface finishes, such as walkways.

The drainage above the waterproof covering and below any raised decking finishes must not be restricted or blocked by the decking supports. The decking supports must allow free drainage of all areas of the roof to the designated outlets:

- Rainwater outlets should be readily accessible without disruption to the pedestrian finish. On finishes raised above the waterproof membrane (warm deck roofs) or Water Control Membrane (inverted roofs), this may be achieved by a suitably marked paving slab or demountable section of decking.
- Where rainwater downpipes from other higher roof areas, balconies or terraces discharge via a lower balcony or terrace, an open downpipe shoe is not permitted. The downpipe should be connected directly to the downpipe serving the lower balcony or terrace.

Rainwater outlets

The following should be confirmed by reference to the manufacturer's information or independent certification, as appropriate:

- Capacity in litres per second at a range of typical water heads.
- Compatibility with the waterproof membrane.
- Integral insulation to avoid condensation.
- Method of attachment.
- Rainwater outlets for inverted roofs should be of the dual height type, designed to maximise removal of rainwater at WFRL level.

Overflows

Roofs which drain to a single internal outlet or combined outlets connected into a single downpipe, should be provided with an overflow to drain and warn of outlet/downpipe blockage and so avoid the risk of flooding or structural overloading. The capacity of the overflow should be not less than that of the outlet or combined outlets, and its discharge should be visible but directed away from the building.

Overflows should be conspicuously positioned for inspection and as close to the outlets as practicable to avoid rainwater build up on roofs.

The overflow level should be set at the design water level for the rainwater outlets, which in most instances is 30-35mm above the outlet. Where there is a sump included at the rainwater outlet position, the overflow should be set at the level of the lip into that sump.

The level of overflows should be 25 mm below the underside of the any sill positions e.g. thresholds.

Box gutters

It is not generally necessary to provide separate box gutters where two planes of roofing intersect, or where a single plane falls to an abutment. In the latter case, there will be no fall between outlets, so consideration should be given to creating these in the structure or insulation. Box gutters are slow, difficult to construct and introduce unnecessary complexity. The need to maintain a fall in gutters and comply with the energy requirements of the Building Regulations may be difficult to achieve.

Drainage layout options

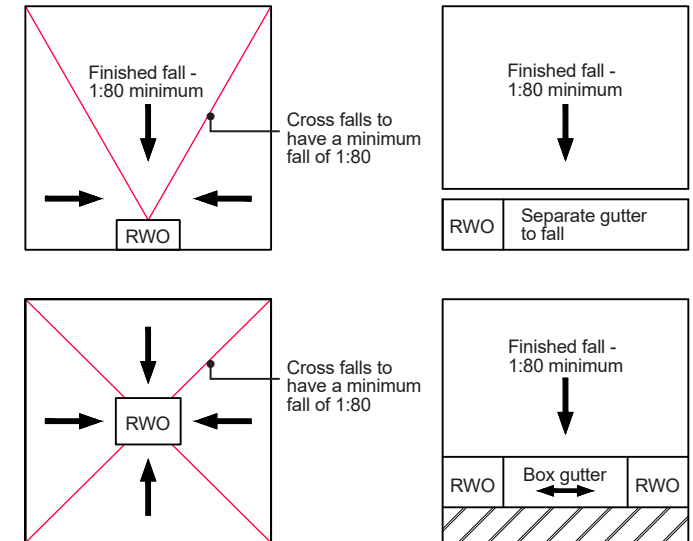

Note: Gutters must also have a minimum 1:80 fall towards the RWO.

Drainage layout options are for illustrative purposes only and should be further developed by a suitably experienced drainage designer prior to roofing work commencing.

Where RWOs are shown, they may or may not be sumped and will be dependent on the drainage design.

Siphonic drainage

All waterproof membranes are compatible with siphonic roof drainage systems, which for larger roofs offer many advantages:

- Very high capacity, enabling fewer outlets and therefore less detailing work on-site.
- Smaller bore horizontal collector pipe work, enabling reduced roof void depth.
- Self-cleaning in many situations.

Note: Siphonic drainage is generally not appropriate for inverted roofs.

For further information see www.siphonic-roof-drainage.co.uk

These roof proposals are to be considered on a case by case basis and full design and calculations should be submitted for Warranty approval before construction begins on site.

Materials

Compatibility of components

The selection of components within the roofing system should be discussed in detail with the membrane manufacturer or appropriate trade association to ensure chemical and mechanical compatibility between components, since the incorrect specification may lead to reduced performance or premature failure of the roofing system. The correct choice of insulation is also important when it is to be adhered to the substrate. In case of doubt, the insulation manufacturer or relevant trade association should be consulted.

General

Materials for use in flat roofing systems are suitable only if the manufacturer has declared compliance with the relevant harmonised European Assessment Document EAD (previously a European Technical Assessment Guideline, ETAG) and has an affixed CE Mark to the product. All waterproof membrane products shall also have a certificate of fitness for purpose issued by a member of the European Union of Agrément (UEAtc). This may comprise a British Board of Agrément certificate or an equivalent certificate of another UEAtc member.

Requirement

The waterproof membrane should be selected with regard to the following minimum criteria:

- Anticipated service life based on independent certification.
- Minimum maintenance.
- Ease of adaptation and repair.

External fire performance

All roof coverings within close proximity of buildings must achieve the fire designation required by the relevant Building Regulations.

Statutory requirement

Design for external fire performance must comply with current Building Regulations.

Certification of system

The manufacturer of the waterproof membrane must demonstrate by reference to independent test certification that the system of waterproofing and insulation (type and thickness) for a particular project meets or exceeds the minimum level of fire performance defined by the Building Regulations.

Polymeric single ply membranes

The manufacturer should declare compliance with the harmonised European Product Specification for single ply membranes, BS EN 13956, which defines requirements for testing and declaration of characteristic values.

There is no relevant British Standard. Products suitable for roofing should have current certification as detailed in 'Appendix C'.

Such certification should be accompanied by full instructions for installation.

There is no British Standard for the installation of single ply membranes. Installation should be in accordance with the Single Ply Roofing Association's Design Guide to Single Ply Roofing and with the specific instructions of the membrane manufacturer.

The attachment of the single ply membrane should be designed to resist calculated wind load by a declared safety factor of two times (200%). This design will normally be provided by the membrane manufacturer.

Whatever the means of attachment, specific restraint is always required at the roof perimeter, at changes of slope and around details. This ensures that any tension in the membrane in the roof field or upstand is not transferred to the other as a peeling action.

Perimeter restraint is achieved by several methods, depending upon the manufacturer:

- Individual fasteners, protected by a flashing.
- A linear bar, protected by a flashing.
- Clamping underneath a mechanically fastened, membrane-laminated trim, with the line of fixings waterproofed by a cover strip.
- Welding the field sheet to a membrane-coated metal trim secured to the deck (with thermal break fasteners where appropriate). This is not recommended for fully adhered membranes.

If the remainder of the roof system is to be bonded, it is essential that the design resistance to wind load is also achieved for the attachment of these components.

Irrespective of the wind uplift considerations or distribution requirements for securing the membrane, the fixing of the insulation boards should always be considered separately, unless specifically sanctioned by the membrane manufacturer. The number and distribution of mechanical fasteners required to fix the insulation boards may vary with the insulation type, geographical location of the building, topographical data and the height of the roof concerned.

The upper termination of the single ply membrane at linear details such as plinths, parapets, abutments and door openings should be secured by one of the following mechanical means:

- Clamping beneath a metal rail, e.g. a parapet capping or roof light frame.
- Welding to a membrane-metal laminate trim (itself mechanically fixed).
- Mechanical fixing using individual fasteners or a mechanically fixed termination bar.

The welding of single ply membranes is a critical process. The following should be considered:

- Supply of certification for each installer indicating successful completion of the manufacturer's product specific training.
- Provision of consistent electrical power supply.
- Production and retention of test weld samples at the start of each day.
- Declared procedures for repair of weak welds or damage.

Methods of restraint of a single-ply membrane at perimeters

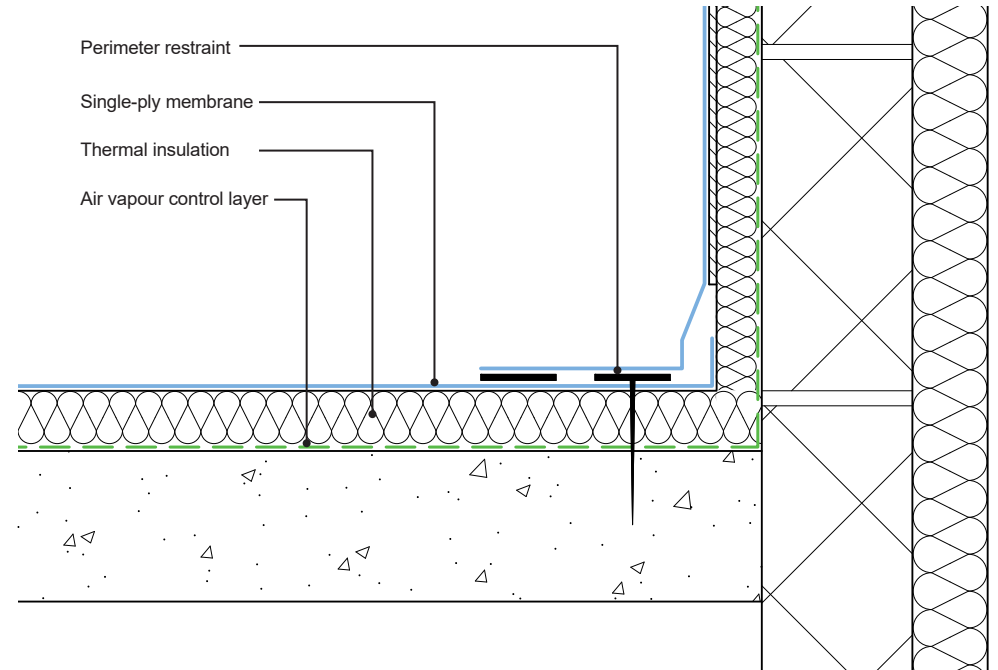

Warm roof systems with polymeric single ply membranes

Where the insulation is mechanically fixed, the number and arrangement of fasteners required to resist wind load will be prescribed by the manufacturer, applying a safety factor of two to the design load on each fastener. This arrangement may vary across the roof according to wind load, but should be followed in all areas. Thermal break fasteners shall be used wherever feasible.

Where the insulation is adhered, the adhesive should be approved by the insulation manufacturer and should be laid at the coverage rate and pattern designed to achieve calculated wind load with a safety factor of two times (200%). The contractor should allow for temporary loading as required to achieve a suitable adhesion and to achieve the best possible level in the upper surface of the insulation.

Liquid applied membranes

Liquid applied membranes consist of a material or combination of materials where at least the main component is a liquid form. There is no harmonised European Product Specification for liquid applied membranes for roofing. There are many types of liquid applied membranes and many may be covered by European Assessment Document (EAD) 030350-00-0402 'Liquid Applied Roof Waterproofing Kits' (EADs are the basis for issuing European technical assessment (ETA's) certificates).

European Assessment Document (EAD) 030350-00-0402 should be used for systems that are:

- Polymer modified bitumen emulsions and solutions.
- Glass reinforced resilient unsaturated polyester resins.
- Flexible unsaturated polyesters or Reactive poly(methyl) methacrylate (PMMA)
- Hot applied polymer modified bitumen.
- Polyurethane, Polyurea or Polyaspartic.
- Silane modified polymers (SMP)/Silane Terminated Polymers (STP).
- Water dispersible polymers.
- Thermoplastic block copolymer.

European Assessment Document (EAD) 030019-00-0402 should be used for systems that are:

- Polysiloxane (waterproofing on the basis of a silicone).

The manufacturer of a product for use in flat roofing should declare compliance with the relevant parts of the relevant European Assessment Document (EAD). In the absence of this declaration, the product should have a current certificate of fitness for purpose issued by one of the following:

- British Board of Agrément.
- Another member of the UEAtc.
- Another notified body.

Such certification should be accompanied by full instructions for installation.

Further information on these generic types of liquid applied membranes can be found on the Liquid Roofing and Waterproofing Association (LRWA) website www.lrwa.org.uk.

Installation of liquid applied membranes

There is no British Standard for the installation of liquid-applied membranes. Installation should be in accordance with the Liquid Roofing and Waterproofing Association guidance, as follows:

- Guidance Note No. 2 - Substrates for liquid applied waterproofing.
- Guidance Note No. 4 - Roof, Balcony and Walkway Refurbishment Using Liquid applied Waterproofing Systems.
- Guidance Note No. 5 - Health and Safety Provision for LAWS on Roofs, Balconies and Walkways.
- Guidance Note No. 6 - Safe Use of Liquid applied Waterproofing Systems.
- Guidance Note No 11 – Use of Adhesives for Liquid Flat Roof Systems.
- Guidance Note No 12 – Termination of Waterproofing at Cills and Thresholds.
- Guidance Note No 13 – Drying of Existing Roof Substrates Prior to Installation of Liquid Waterproofing Systems.
- Guidance Note No 16 – Walls Built onto Waterproofing Systems.
- Guidance Note No 17 – Best Practice for the Installation of a Flues Passing Through a Flat Roof.

A consistent film thickness is essential for reliable and durable liquid-applied membranes.

The following should be considered:

- Supply of a card for each installer indicating successful completion of the manufacturer's product-specific training.
- The coverage rate in kg/m² must be declared before work starts.
- During installation assessment of wet film thickness by one of the following methods as appropriate:
- Gauge pin.
- 'Comb' type measurer.
- Visual inspection.

In all cases, where a LARWK roof product/system is proposed, the designer will be required to distribute the following information to all appropriate contractors, site supervisors and suppliers, in a clearly understandable format to demonstrate the installed system provides an adequate level of performance:

- A full third party product conformity approval certificate for the system.
- A full specification for the proposed works prior to works starting on site – this must be accompanied by a full set of drawings covering aspects of detailing.
- The installing contractor must provide evidence of inclusion into an Approved Installer scheme, which is controlled and verified by the system manufacturer.

Insulation for use with liquid applied membranes

Any proposal that requires on site installation of an OSB or plywood sheet over a proprietary rigid insulation board **should only be accepted** when supported by a site specific Condensation Risk Analysis calculation.

The type of insulation used for liquid applied membrane must be confirmed by the manufacturer of both the liquid applied membrane and insulation board manufacturer as being compatible. The insulation core must also be capable of giving support to the completed liquid applied membrane in order to ensure that applied loads do not give rise to cracking or indentation of the finished waterproofing system.

It should be noted that some liquid applied membranes use an adhered carrier or preparation membrane prior to application of the liquid applied membrane. Where this is the case, confirmation should be sought from the manufacturer of the insulation board regarding the compatibility of any roofing system primers or adhesives used for the attachment of the carrier material.

In both instances, the manufacturers of the insulation board should provide any performance data for inclusion into the specification which has been produced for the roofing system.

Insulation products must be manufactured in controlled factory conditions, with manufacturing facilities holding evidence of appropriate Factory Control Certification from a UKAS accredited 3rd Party which confirms they are manufactured to the relevant industry standard. The product itself must be covered by a full third party product conformity approval certificate.

Typically acceptable build-ups

Cold flat roof build ups are not acceptable for roof terraces.

For the purposes of Warranty, a warm flat roof build up is recommended for site applied liquid applied membrane roof coverings. The insulation should be compatible with the liquid applied membrane and method of application.

Detailing

The Warranty Surveyor must receive a full set of sectional drawings, which should be accompanied by the specification. These sectional details should be produced by the system manufacturer for all aspects of detailing specific to the project.

Compatibility with other materials – penetration detailing

For instances where the liquid applied membrane is required to bond onto lead pipe sleeves, flashings, steel balusters, anchoring system, etc., the liquid applied membranes guidance should always be sought prior to works taking place. Incompatible material will often need special preparation and need to be primed with a system specific primer to facilitate a good adhesion of the liquid applied membrane to the material in question.

EPDM roof coverings

EPDM roof coverings are not acceptable where used on a:

- Balcony/terrace decks
- Blue roof
- Green roof
- Podium deck

Site-applied hot-melt coverings

There is no harmonised European Product Specification for site-applied hot-melt waterproofing systems. Hot applied polymer modified bitumen (hot melt) is covered by European Assessment Document (EAD) 030065-00-0402 'Composite Roof Waterproofing Kits'. EADs are the basis for issuing European technical assessment (ETA's) certificates.

The manufacturer of a product for use in flat roofing should declare compliance with the relevant parts of the relevant European Assessment Document (EAD). In the absence of this declaration, the product should have a current certificate of fitness for purpose issued by one of the following:

- British Board of Agrément.
- Another member of the UEAtc.
- Another notified body.

Evidence of appropriate certification should be provided to demonstrate its suitability for its proposed use.

As these systems comprise a multi-layer application (usually a base coat, reinforcement and top coat), a detailed specification for the system should be available prior to commencement of the works to ensure suitability for the project to be confirmed. Reference should be made to independent certification and the manufacturer's detailed instructions.

Mastic asphalt

There is no harmonised European Product Specification for mastic asphalt for roofing. Products used for flat roofing should comply with BS 6925: 1988 Specification for mastic asphalt for buildings and civil engineering (limestone aggregate).

Proprietary grades of polymer modified mastic asphalt are produced for roofing and paving applications. There is no British Standard or European Standard for these products.

- Products suitable for roofing should have current certification as detailed in 'Appendix C'.

The separating membrane should be one of the following, and should be laid directly under the mastic asphalt:

- Sheathing felt, comprising a base of flax or jute, or other suitable fibres, impregnated with bitumen.
- Glass fibre tissue.

Bitumen-coated plain expanded metal lathing should be in accordance with BS EN 13658-2.

Stone chippings (bedded) for use as a protective topping should be washed, crushed rock, normally 10mm-14mm nominal size aggregate, bedded in a proprietary gritting solution over the mastic asphalt membrane.

Generally, mastic asphalt on sheathing felt provides sufficient dead load to resist wind load, but this should be demonstrated by calculations in all situations.

Installation of mastic asphalt

The number of coats should be appropriate to the waterproofing requirements and traffic conditions of the roof. When laid to falls of 1:80 or more, mastic asphalt roofing is laid in two coats to a thickness of 20mm, on a separating membrane of sheathing felt, all in accordance with BS 8218.

On sloping and vertical surfaces over 10° pitch, the mastic asphalt should be laid in three coats to a thickness of 20mm without a separating membrane.

On sloping and vertical surfaces of timber or lightweight concrete, the mastic asphalt should be laid in three coats to a thickness of 20mm on expanded metal lathing over a separating membrane of sheathing felt.

Reinforced bitumen membranes

The manufacturer should declare compliance with the harmonised European Product Specification for reinforced bitumen membranes, BS EN 13707, which defines requirements for testing and declaration of characteristic values. There is no relevant British Standard.

Products suitable for roofing should have current certification by one of the following:

- British Board of Agrément.
- Another member of the UEAtc.
- Another notified body.

In addition, specifications for systems of multi-layer reinforced bitumen membranes for flat roofing should comply with BS 8747.

Minimum recommended specification for reinforced bitumen membranes

Roof system type	Deck type	Insulation type ⁽¹⁾	Venting layer ⁽²⁾	Underlayer ⁽³⁾	Cap sheet ⁽⁴⁾
Warm deck	Profiled metal	Thermoplastic foam	3G	S2P3 ⁽⁵⁾	S4P4 ⁽⁵⁾
		Mineral fibre	-	S2P3	S4P5
	Concrete	Thermoplastic foam	-	S2P3	S4P4
		Mineral fibre	-	S2P3	S4P4
	Timber panel	Thermoplastic foam	3G	S2P3	S4P5
		Mineral fibre	-	S2P3	S4P4
Inverted warm deck	Profiled metal	Extruded Polystyrene (XPS)	3G	S2P3	S4P5
	Concrete		-	S2P3	S4P5
	Timber panel	Deck type not suitable for inverted roofs			

Notes:
 (1) Insulation type: Thermoplastic foam: PIR, EPS, PF. Mineral fibre: MW.
 (2) Venting layer: BS 8747 3G or proprietary equivalent with suitable certification.
 (3) Under layer: as defined in BS 8747. SBS-modified products are recommended.
 (4) Cap sheet: as defined in BS 8747. SBS-modified products are recommended.
 (5) S and P are classifications 1-5 of Strength (tensile strength and elongation) and resistance to puncture (static and dynamic); the higher the rating, the higher the performance.

Bitumen membranes should be protected from solar radiation. This should be by integral protection provided in the product in the form of:

- Mineral granules.
- Metal foil.

The use of solar reflective paint is not permitted. The use of stone chippings is not recommended unless required to achieve enhanced external fire performance. If used, chippings should be washed, crushed rock, normally 10mm-14mm nominal size aggregate, bedded in a proprietary gritting solution.

Warm roof systems with reinforced bitumen membrane waterproofing

The limiting wind load for the different methods of attachment of insulation is prescribed by BS 8217 as follows:

- Partial bitumen bond: up to 2.4kN/m².
- Full bitumen bond: up to 3.6kN/m².

Where the method of attachment is outside the scope of BS 8217, the manufacturer should demonstrate that the method provides sufficient resistance to wind load.

Reinforced bitumen membranes installation

Installation should be in accordance with BS 8217. In case of doubt, or where the waterproof membrane is beyond the scope of the Standard, the advice of the Flat Roofing Alliance (National Federation of Roofing Contractors) should prevail.

The safe use of gas torches, and the positioning, monitoring and transferring hot bitumen to the work face, should be adopted, all in accordance with the Health and Safety Executive/Flat Roofing Alliance Code of Practice for Safe Handling of Bitumen.

The practice of applying reinforced bitumen membranes by torching onto thermoplastic foam insulation is not permitted, unless the boards are manufactured with a covering of reinforced bitumen membrane.

Fixing of guarding/balustrades

Fixings for balustrades must be carefully designed to ensure appropriate fixings are robust and any penetration through waterproof roof coverings is fully sealed correctly to prevent any risk of moisture penetration. A pinch pocket with an upstand of 150mm is a suitable method of sealing these details.

Protection of waterproof system during construction

At the earliest possible stage, the anticipated loading of the balcony, terrace or podium area by plant and access during service should be assessed in terms of:

- Load, e.g. foot traffic, equipment.
- Frequency.
- Risk of impact.

If such usage is intense or long-lasting during the construction phase, consideration should be given to temporary works only, with completion occurring after all non-roofing usage has ceased as follows:

- Warm deck roof system: installation of temporary vapour control layer (VCL) to be overlaid when remainder of system is installed.
- Inverted warm deck roof system: overlay of completed waterproof membrane with geotextile and continuous temporary decking, such as plywood, oriented strand board or compatible recycled thermoplastic board.

Responsibility for temporary protection and a method statement for its use should be agreed prior to the commencement of works. Suitable materials should be selected in consultation with membrane manufacturer as appropriate, for example:

- Linked recycled thermoplastic sheets.
- Rolled recycled thermoplastic or elastomeric sheets.

Particular consideration should be given to locations of concentrated access, such as step-out areas onto the roof or where wheeled equipment may be used.

Provision for access

Statutory requirement

Roof terraces should have suitable access and drainage meeting the requirements of the current Building Regulations.

Ancillary components

Lightning protection

Where provided, the manufacturer's information or independent certification should be followed. Guidance may be found in BS EN 62305. We would require details of:

- Design in compliance with BS EN 62305.
- Method of attachment to the waterproof membrane, including arrangements for self-ballasting of conductors and finials (centres, compressive loads).
- Recommended detailing at penetration of roof system.

Detailing

The following key principles should be followed in the design of all details:

- Upstands to extend 150mm above finished roof level, except at door access to roof terraces.
- Downstands (of separate metal or other flashings) should lap the upstand by a minimum of 75mm.
- Where the terrace forms part of the entire roof of an occupied building, a continuous barrier to air leakage should be maintained.
- Reliance on sealants as the sole means of protection from moisture ingress is not an acceptable approach.

The total roof terrace zone depth should be assessed at critical points, to ensure there is enough space to provide a 150mm upstand to provide waterproofing protection above finished roof level. It is important that this minimum 150mm upstand is maintained at all points around the waterproofed area. A 75mm upstand may be permissible at door thresholds subject to review.

The following design features for a successful design of a level threshold are essential:

- Minimum clearances are maintained to enable the waterproof membrane to be installed.
- Continuity of the membrane across the whole field area of the roof terrace. All Terminations of the waterproof membrane at interfaces to other elements are to consider potential expansion and contraction of the membrane used.
- Sills are adequately supported to ensure no damage to the sill over the long term.
- Thermal bridging is avoided through provision of continuity of the thermal line or thermal breaks as appropriate to minimise heat loss and condensation risk.

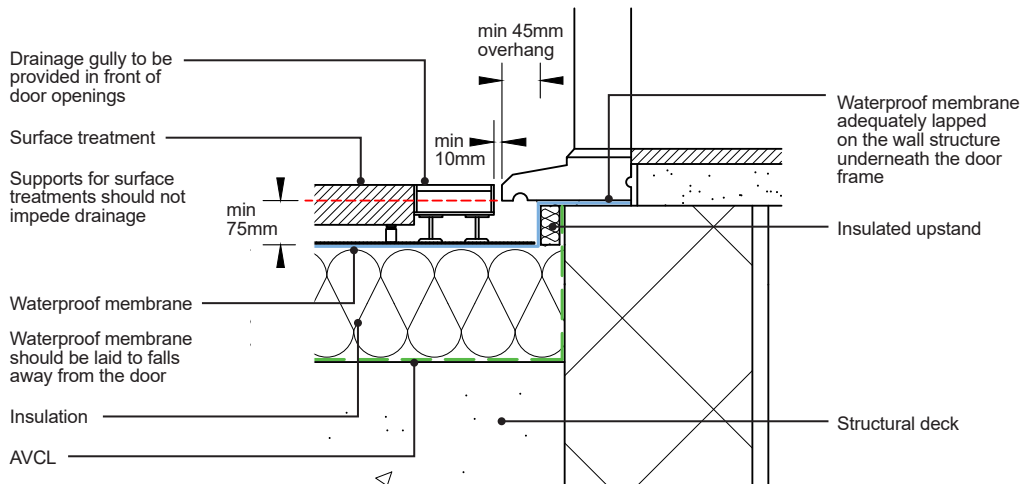
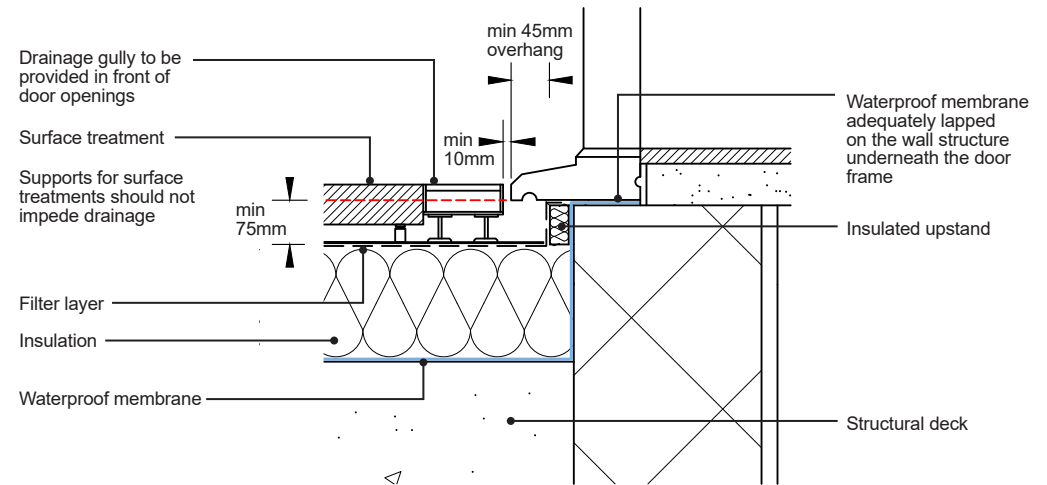
Upstand at door access - Warm deck roof - Level threshold**Upstand at door access - Inverted warm deck roof - Level threshold**

Penetration through a roof terrace

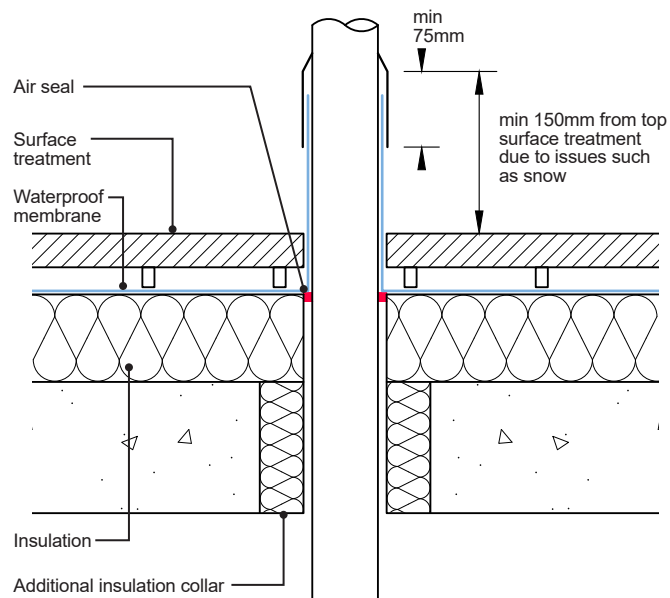

Notes:

- Upstands to extend 150mm above the finished roof level.
- Downstands (of separate metal or other flashings) should lap the upstand by a minimum 75mm.
- A fillet is required at the base of the upstand for certain types of waterproof membrane. Roof membrane manufacturer specification should be followed.
- An effective seal is required between the air vapour control layer and pipe. Clearly it is difficult to dress a sheet material around a pipe. The method for doing so should be stated in the contract drawings and/or specification.

Special design features

Special design features are essential, depending upon the generic type of waterproof membrane, including:

- Minimum clearances to enable the waterproof membrane to be installed.
- Termination of the waterproof membrane at interfaces to other elements.
- Penetrations.
- Supports.

Mechanical and electrical services

Detailed design should take account of the installation of such equipment by other (usually following) trades, as follows:

- Service entry/exit points should be suitably weathered to enable connection without loss of integrity of the waterproof membrane and without the involvement of the roofing specialist.
- The upstand of the waterproof membrane at risers should be arranged to enable a separate downstand or weathering flashing to be formed in ductwork.
- Sufficient clearance should be provided to horizontal ductwork to ensure it does not rest upon the waterproof membrane or roof finish.

Support for renewable energy capture equipment

Renewable energy capture equipment includes photovoltaic panels and multi-panel arrays, solar thermal panels and multi-panel arrays and wind turbines. All such equipment should be secured to a frame and/or posts that transfer their load directly to the structure. The roof system and waterproof membrane should be designed to enable equipment to be de-mounted without loss of the roof's waterproofing integrity and without the involvement of the roofing specialist. Support systems based on 'top-fixed' plate and post components should be accompanied by documentation to demonstrate their compatibility with the waterproof membrane.

Principles: Flat roof interface to pitched roof

Flat roof abutting a pitched roof

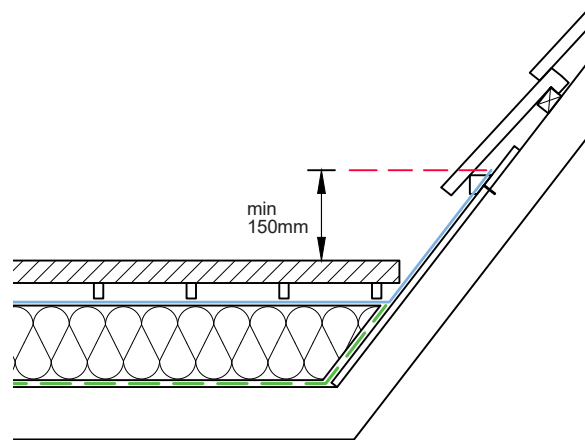

Pitched roof abutting a flat roof

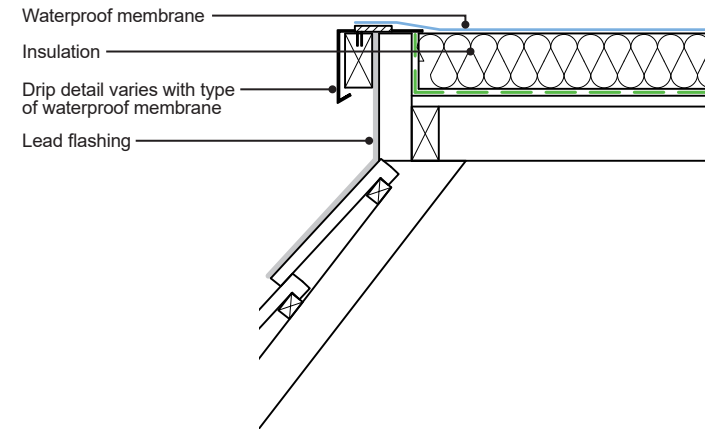

Edge protection/guarding

The guarding to the perimeter of a roof terrace should be designed to minimise laps and complex junctions to achieve waterproofing integrity. Installation of balustrade or glazing stanchions may occur after the installation of the roof system, this should be avoided where possible.

Acceptable examples include the following, in order of preference:

Full-height parapet walls:

- Stanchions or rails secured to low parapet walls above the level of the waterproof membrane (incorporated in copings or secured to elevation).
- Stanchions secured, clamped and sealed to stainless steel bolts set in raised plinths, which were constructed prior to application of the waterproof membrane (suitable for warm deck and inverted warm deck roof systems).
- Stanchions secured, clamped and sealed to stainless steel bolts set at deck level, which were installed prior to application of the waterproof membrane (suitable for warm deck roof systems only).

If the design requires a collar of waterproof membrane at the stanchion, the stanchion should be of circular section at this point and should incorporate a weathering apron.

For further guidance, please refer to the 'External Walls – Parapets' section.

Fall-arrest and edge protection equipment

The following should be confirmed by reference to the manufacturer's information or independent certification, as appropriate:

- Compliance with BS EN 795.
- Method of attachment.
- Compatibility with the waterproof membrane.
- Means of forming a water tight seal to the waterproof membrane.

Upstand to decking and paving finishes - e.g. where access is required

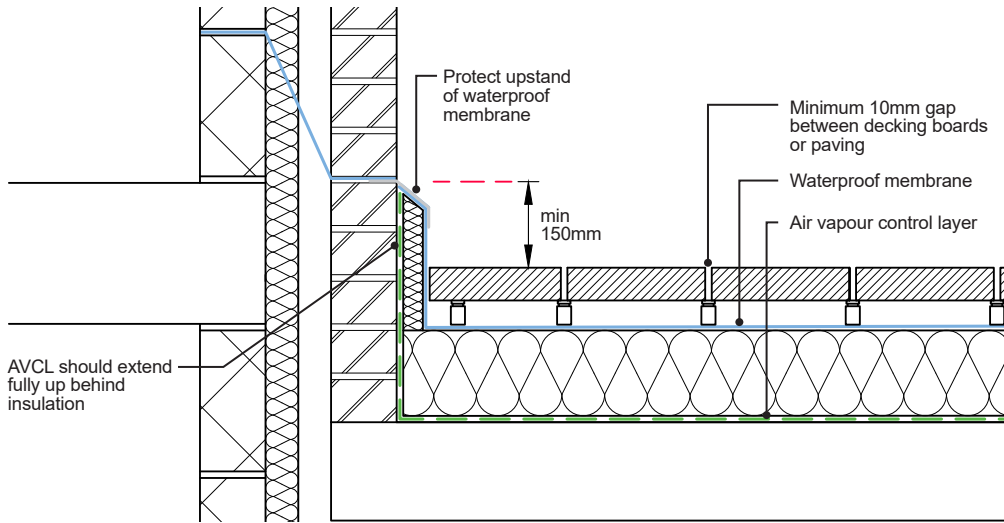

Allowance for movement where a timber frame with masonry cladding abuts a flat roof

Where a timber frame structure abuts a masonry structure allowance should be made to accommodate movement in the timber frame and ensure the appropriate cover is maintained.

For detailing with parapet wall construction, see the 'External Wall - Parapets' section.

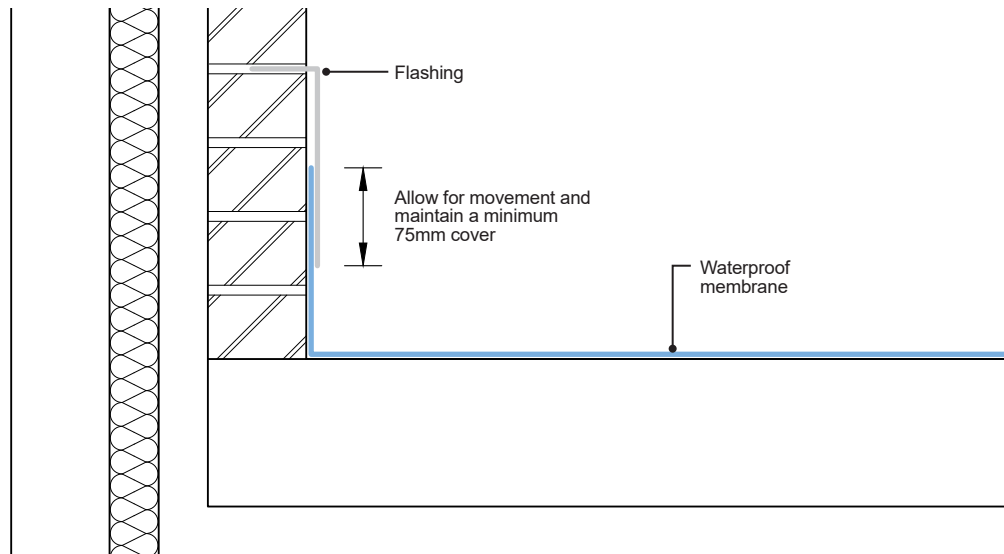

Pedestrian surface finishes

- The design should include protection to suit the anticipated conditions as appropriate.
- Pedestrian access finish and there supports should not impeded the ability for the terrace to drain to all outlets.
- Supports or pedestals to pedestrian finishes should not be mechanically fixed through the waterproof membrane.
- All pedestrian access finishes should comply with the relevant Building Regulations in regards to combustibility requirements in regards to a relevant boundary.

Pedestrian finishes for roof terraces

Finish	Roof system type		Waterproof membrane type			
	Warm	Inverted	Single ply membrane	Bitumen membrane	Mastic asphalt	Liquid applied
Porous concrete tiles adhered to waterproof membrane (1)	Y	N	N	Y	Y(2)	Y
Fired tiles bedded in screed and grouted (1)	Y	N	Y	Y	Y(2)	Y
Precast concrete paving slabs on adjustable supports (3,4)	Y	Y	Y	Y	Y	Y

Notes:

- (1) Product should be certified for use with waterproof membrane.
- (2) Consideration should be given to the effects of solar gain on the stability of mastic asphalt under point loading in this situation.
- (3) Paving support pad bearing area should be suitable for the compressive strength of the insulation under design loadings.
- (4) Bearers should not impede drainage, and should be sized to suit the compressive strength of the insulation under design loadings.

Non-access areas: stone ballast

Stone ballast for inverted warm deck roofs and ballasted warm deck roofs should be clean, rounded aggregate graded 20mm-40mm and as free from fines as practicable. Ballast should be applied over a protection layer on warm ballasted systems and over a filter layer or WCM on inverted warm roofs and suitably provided to prevent wind uplift.

Access areas: concrete paving slabs

Concrete paving slabs for use as walkways or as paving on terrace decks should conform to BS EN 1340, and be laid in accordance with the manufacturer's instructions.

It is recommended that concrete paving is laid on support pads as this allows adjustment, reducing risk of trip hazard. Recommendations are as follows:

- The height of support pads should not exceed the maximum recommended by the manufacturer.
- Paving should not be cut.
- Paving should be firmly butted up against support pad separating pegs.
- Support pad separating pegs should provide clear space for rapid disposal of rain water between paving slabs.
- Provision for movement at perimeters should comprise either a 75mm margin of washed stone or a compressible rubberised fill. In either case drainage should not be obstructed and a suitable restraint trim should be used to ensure stone does not fall beneath the paving adjacent.

Access areas: flexible walkway tiles

Evidence of the compatibility of the tile with the waterproof membrane is required.

Testing

Final inspection

At practical completion of the balcony/terrace, all areas should be clear of stored material, other site operations and all protection. A thorough, recorded, visual inspection of all areas, including details, should be carried out with representation from the General Contractor and Roofing Contractor in attendance.

Parameters for testing

Upon completion testing of the flat roof covering will be required to be carried out as per the following criteria.

Testing of roof terraces (All types of materials)

Testing is required in the following situations:

- On Low rise housing: Detached/semi-detached/terraced housing 3 stories or less in height (including the ground storey) when:
 - The roof/roof terrace areas exceed 50m² or,
 - Where the project consists of 10 or more properties: one test per ten houses (with a minimum of two tests per site) are required.
- On large developments: Apartments etc. over 3 stories in height (including the ground storey), where the total combined roof terrace areas exceeds 50m². In this case, a minimum of 20% of the roof areas must be tested.
- On developments involving our Major Projects team, all roof terraces will require low voltage testing.
- Where, after the completion of the site risk assessment, the Warranty Surveyor has identified areas of complexity (for example service penetrations, abutments with claddings and/or penetrations from fixed items such as guarding) in relation to the roof and its ancillary components that present a higher risk to Warranty.

These areas of complexity may be resultant of elements of:

Design where:

- If the roof terrace includes features beyond a typical wall abutment e.g. (but not limited to); variations of upstand constructions/penetrations/fixings/external permanent machinery/balustrading fittings etc.
- If the waterproof membrane is to be covered over (by pedestrian finishes or solar panels). Note: Inverted roofs of straightforward design and with continuous hot-applied waterproof membrane could be exempted.

Construction where:

- If there are to be/have been, follow on trades on the roof terrace after completion of the roof terrace covering.
- If secondary items such as fall protection devices, PV supports, balustrades etc. are to be attached.

In all circumstances, testing should be carried out when the first roof terraces are completed in order to determine if there are any inherent issues with the design or workmanship. Where there is a failure the root cause should be determined and appropriate remedial actions should be taken. The Warranty Surveyor may request an increase in the amount of testing required.

Procurement of testing services

If testing to demonstrate waterproofing integrity is required it should be undertaken by a suitably qualified and experienced third-party who is independent of the installing contractor.

The testing service provider should provide evidence of the following:

- Efficacy of the method proposed in the circumstances of the project.
- Detailed testing regime that includes integrity testing of detailing specifically where the Warranty Surveyor has raised these as elements of particular complexity within the site risk assessment.
- Experience and training of operator.
- Membership of an appropriate trade association that sets a Code of Conduct for the service.

Methods of test

Low voltage earth leakage

Low voltage earth leakage is a safe and effective method for the testing of waterproofing integrity in roofs where the waterproof membrane is an electrical insulator and the deck provides an electrical earth. It is not suitable for testing flat roofs where the waterproof membrane has been overlaid with insulation and ballast (inverted roofs) or ballast only (ballasted warm roofs); therefore, testing should be carried out prior to completion of the roofing system.

Voltage field mapping

Voltage field mapping uses a generator, trace wire and field electrodes on a roof with a thin layer of water spread across the selected test area. The trained operator uses electrodes and generated voltage flow to determine the presence and precise location of defects in the area being tested.

High voltage electrical discharge

High voltage electrical discharge method is a versatile and effective method of testing. It can be used on steep slopes or inverted surfaces, provided the underlying structure will provide the necessary ground. Can be used for single ply (check with the relevant manufacturer before testing), reinforced bitumen membranes and liquid applied coatings.

Vacuum

Vacuum testing of seams of membranes manufactured off-site is an effective means of quality assessment, but is not recommended as a method of demonstrating the integrity of flat roofs.

Flood testing

Flood testing is not recommended as a method of demonstrating the integrity of flat roofs. It may be used to test balconies.

Approved installers

In all circumstances, the roof terrace membrane system will need to be installed by an approved contractor who is recognized by the manufacturer as competent. Evidence of the manufacturer's approval of the contractor to install their products should be provided to the Warranty Surveyor.

Typically, this is in the form of an identity card, which features the installer's name; a passport-style photograph; a unique card number; an expiry date; the manufacturer's name and logo; and lists the products and/or systems for which the installer has been trained.

Periodic inspections

Periodic inspections should be completed in line with the advice provided within the Operation and Maintenance Manual for the project, by an appropriately skilled or trained party. The operations and maintenance manual should be provided to the home owner upon completion.

As a minimum it is advisable that a roof terrace is inspected at least twice yearly. Typically in the autumnal period of the year to ensure outlets are operational and the roof terrace is free draining to deal with any subsequent inclement weather conditions in coming winter months. A further inspection is then carried out in spring to discover and rectify any damage due to weather. Extra inspections are advisable following any extreme weather events or where it is suspected that vandalism, and/or theft may have occurred on the roof terrace.

As a minimum, it is advisable that any inspections should include the following elements:

- An examination of ceilings for signs of water damage;
- An examination of external walls, eaves, critical junctions and soffits for signs of movement;
- Signs of damage to the roof surface and subsequent layers of construction along with associated flashings;
- Mounted or ballasted roof top installations e.g. safety equipment, communications and renewable energy installations should be examined to ensure their attachment and associated work remains waterproof.
- Extensive build-up of leaves, moss, plants or debris should be recorded along with any influencing factors such as the effect of overhanging trees, mounted plant items, etc.

It is advisable that when additional construction work is planned on or near to the roof, an appropriate and specific inspection regime is established to cover the aspects of risk associated with the work at hand.

12.

Roof

**Terraces and
Balconies**

12.2

Balconies

Provision of information

A full set of design drawings and specifications shall be made available to the Warranty Provider and all other interested parties prior to the associated works starting on site. This may include:

1. A full set of detailed drawings including:
 - a) Balcony identification plan clearly indicating all balcony types e.g. projecting balconies, inset balconies, access decks/ walkways, Juliet balconies.
 - b) Plan showing direction of falls and position of outlets and overflows.
 - c) Details of all critical junctions including support of the threshold and any upstand interfacing with the façade.
 - d) Details of the provision of pedestrian surface support structure (where appropriate).
 - e) Details of the provision of guarding including parapet walls and balustrading used as guarding, should be designed in accordance with BS EN 1991-1-1 to resist horizontal loading and as required by the Building Regulations.
 - f) Details of all fire stopping which should include specification and a detailed location layout drawing showing positioning of all fire stopping.
2. A detailed drainage strategy for all balconies.
3. A full structural design by an Engineer.
4. Details of fixings, their frequency and fixing method, including those for surfacing materials.

The Warranty Surveyor, at their discretion, may also request supporting information that demonstrates suitability for use of any materials or systems contained within the above.

Definitions

Balcony - A balcony is a building component which is an accessible external amenity platform above ground level which is exterior to and with direct access from a building. A balcony can project beyond the walls of a building; it can be formed within a recess of a building; or it can be a hybrid of both as further explained in this section. A balcony does not form part of the thermal envelope, e.g. not forming a roof.

Balconies may take the form of:

- **Access balcony:** providing pedestrian access to two or more dwellings. (Sometimes referred to as a 'walkway' or 'access deck').
- **Projecting balcony:** an accessible external amenity platform affixed to the exterior of a building above ground level exterior to and with direct access from a building.
- **Enclosed balcony:** protected from rain by a roof or balcony above and walls or weather screens to the sides, (sometimes referred to as a 'winter garden').
- **Free-standing:** fully, or partially, supported independent of the building structure.

A 'balcony' formed over an accommodation is a 'Terrace', please see the 'Roof Terraces and Balconies – Roof Terraces' section.

Examples of different balcony types

1. Access balcony
2. Projecting balcony
3. Enclosed balcony
4. Free-standing balcony

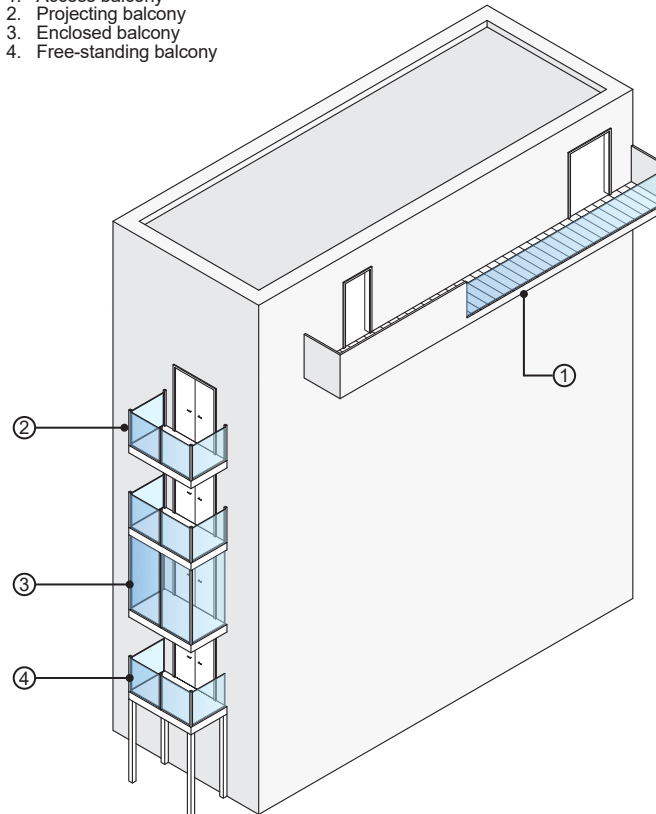

General design requirements

Balconies which follow the guidance in this section will be generally acceptable to meet the Functional Requirements of this Technical Manual.

The designer must be aware of the specific scope of the applicable Warranty Policy in context of the limitations of the Technical Manual guidance compared with additional requirements contained within other standards e.g. BS 8579, which may extend beyond the scope of our requirements. The designer may consider their own design aims, beyond the minimum requirements of the Technical Manual in any specification and in this instance BS 8579 may be consulted by the designer.

List of standards

- BS 6229 Flat roofs with continuously supported flexible waterproof coverings. Code of practice.
- BS 8579 Guide to the design of balconies and terraces.

Structural Design Requirements

Balconies should be designed to meet the following requirements:

- Balconies should be designed to meet BS EN 1991-1-1, BS EN 1991-1-3, BS EN 1991-1-4 and BS 8579 for balconies. Due consideration of any added surfacing; paving slabs, decking boards etc. Snow loads should be assessed in accordance with BS EN 1991-1-3 + UK National Annex. Wind loads should be assessed in accordance with BS EN 1991-1-4.
- Balconies should be designed to address both short term and long-term deflection to provide an effective drainage strategy with no back falls or ponding.
- The resistance to wind uplift of the waterproof covering and finishes on a balcony should be assessed having regard to the dead weight of those materials and to the nature, type and disposition of their attachment to the slab or deck, in accordance with BS 8217 and BS EN 16002.
- Balconies should be designed to have adequate crack control/dimensional stability to avoid damage to directly applied AVCL and waterproofing layer, particularly liquid applied waterproofing.
- It is common for several designers to be involved in different elements of the balcony structural design; for example, interfaces with the main structure, guarding and balustrading design etc. There are risks associated with methods of procurement which introduce multiple interfaces. There should always be one party with a responsibility to assure that the final design, as a whole, is acceptable.

Balconies are usually designed to limited load capacities and as such additional excessive loads should be anticipated to avoid any potential structural failures. Examples include planters or using the balcony for storage purposes.

Durability

All structural components must have a service life of at least 60 years unless otherwise stated.

Prefabricated balcony structures should have third party accreditation and have a service life of at least 60 years.

Timber durability

For Warranty purposes, timber should only be considered for projects up to 2.4m from the external ground level. Please note, the use of Timber for non-structural components may be restricted by relevant Building Regulation and other legislative requirements.

Please refer to 'Appendix C' for further guidance on service life requirements for the use of timber in balconies.

All structural timber used should be stress graded. All such timber must be stamped as either 'DRY' or 'KD' (Kiln Dry). The use of ungraded, or 'green', timber is not acceptable.

The design should be in accordance with:

- The Code of Practice 'Balconies on new homes' published by TDCA, or an Engineer's design.

The balcony design should take account of possible differential movements within the slab/deck and at junctions with supporting structure, parapets, kerbs and upstands.

Note: Such movements might be caused by movement of the structural frame or by changes of temperature and moisture content.

Preventing water ingress

Care should be taken to prevent water ingress from the balcony area to the internal habitable space, structure or building envelope to which the balcony structure is attached. Junctions with the main structure and threshold detailing should be considered during the design stage.

Junctions with main structure and threshold detailing

Where a waterproofing layer is used, a 75mm upstand should be formed with the waterproofing layer. The door threshold sill and drip should form a minimum 45mm overhang. A 10mm gap between the drainage gully and door threshold sill should be provided.

The same principles apply for off-site prefabricated balconies, the manufacturer should be consulted for specific detailing.

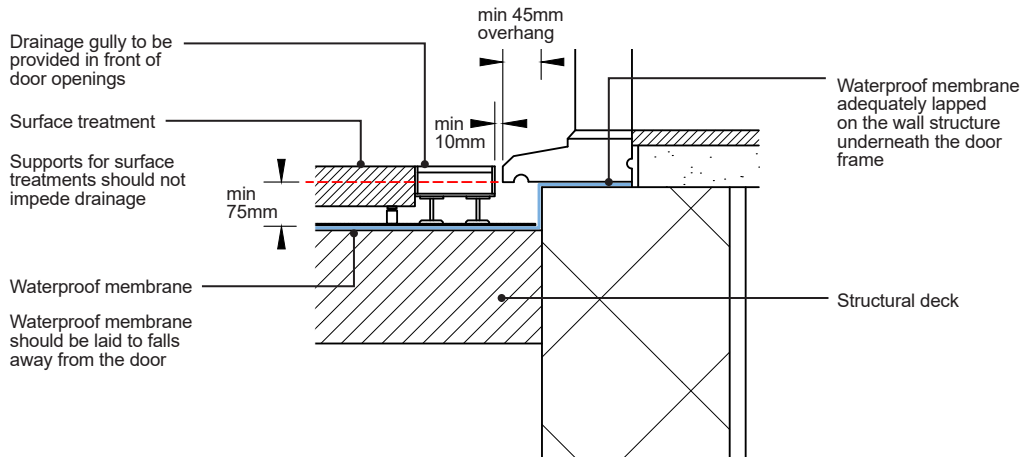

British and industry standards

The requirements of BS 6229 should prevail in respect of balconies irrespective of the type of waterproof membrane.

Falls

- Balconies should be designed to fall away from the building elevation.
- A minimum finished fall at any point of 1:80 (1.25%) should be achieved.
- Since adjoining roof planes at 1:80 will meet at a mitre of less than 1:80, the intended finished fall at such intersections should be considered at an early stage.
- Design falls should take account of any potential deflection and construction tolerances. In the absence of detailed a justification, this may necessitate design falls of twice the minimum finished falls (1:40 or 2.5%).
- The manufacturers' of certain waterproofing products have certification for their use in 'completely flat' or 'zero falls' applications. For Warranty purposes, all balconies must be designed to 1:80 falls to avoid backfalling.

Consideration should also be given to:

- The available upstand height at the high end of the falls. This may be a limiting factor on the length/size of the balcony/terrace area to be drained. If necessary additional rainwater outlets should be provided.
- Avoidance of ponding behind wide obstructions to the drained slope such as plant plinths. Additional rainwater outlets should be provided.
- Falls between rain water outlets along a perimeter.

Waterproof coverings of all types are tested for water absorption and water tightness as part of third-party certification. However, the construction process, including the installation of components and the forming of seams, is clearly facilitated in dry, well-drained conditions.

Creation of falls

Falls may either be created during the construction of the deck or by applied cementitious screeds. Cementitious screeds provide a stable substrate to mitred falls with minimal tolerances, and are recommended. Screeds should be in accordance with BS 8204.

Paving support systems must be designed so that they take into account the maximum height formed when considering the falls for the balcony.

Drainage design for balconies

The following drainage approaches are suitable for Warranty:

- Positively drained
- Edge drained
- Free drained

Positively drained

All inset or semi inset balconies must be positively drained. Other drainage approaches are not acceptable in this arrangement.

With a positively drained balcony design, water is collected on a waterproof surface and directed to a piped outlet into the wider drainage network. An over flow is used to warn of outlet/downpipe blockage and so avoids the risk of flooding to the balcony area.

A positively drained balcony design should be based upon calculations in accordance with BS EN 12056 Part 3. Rain water outlet capacity should be taken from properly certificated information provided by a manufacturer, the resulting number and layout of outlets should avoid the potential for obstruction, for example by the decking supports. Sub frames or pedestal deck systems must be designed to mitigate the potential risks of point loads on the waterproofing product which could cause localised degradation to the waterproofing system.

The drainage above the waterproof covering and below any raised decking finishes must not be restricted or blocked by the decking supports. The decking supports must allow free drainage of all areas of the roof to the designated outlets:

- Rainwater outlets should be readily accessible without damage of the pedestrian finish. This may be achieved by a suitably marked paving slab or demountable section of decking.
- Rainwater from higher roof areas and/or higher balcony areas must not discharge directly onto a lower balcony construction unless formally agreed with the Warranty Provider prior to works commencing.

Rainwater outlets

The following should be confirmed by reference to the manufacturer's information or independent certification, as appropriate:

- Capacity in litres per second at a range of typical water heads.
- Material compatibility with the waterproof membrane.
- Method of attachment within the substrate.

The outlet should not be positioned adjacent to the threshold. It is recommended that the outlet is positioned at any point between the leading edge and 1/3 of the length of the balcony from the threshold as per the below detailing.

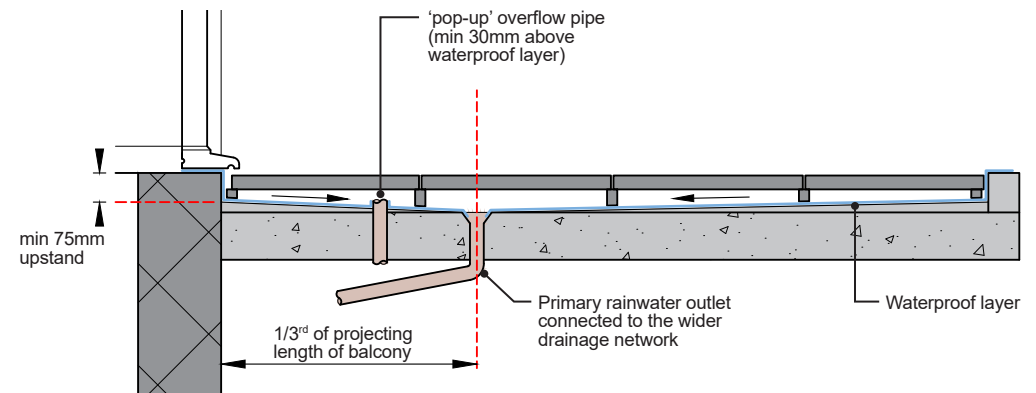

Red line shows 1/3rd of projecting length of the balcony. Details relating to pedestrian surface and guarding omitted for clarity.

Overflows

A conspicuous overflow should be provided. It is recommended a pop up overflow pipe protruding 30mm above the waterproofing layer is provided. It should be positioned in the zone between the threshold and 1/3 of the projecting length along the balcony. It may be offset along this position but its height must be a minimum of 25mm below any thresholds.

Balconies which drain to a single internal outlet or combined outlets connected into a single downpipe, must be provided with a conspicuous overflow. Its function is to drain and warn of outlet/downpipe blockage and so avoid the risk of surcharging the upstand which can lead to moisture ingress. The capacity of the overflow should be not less than that of the outlet or combined outlets and its discharge should be visible but directed away from the building.

Edge drainage

This is a design approach which allows water to quickly pass through a pedestrian surface through to a soffit collection tray or impervious surface laid to falls. Where it is then momentarily collected and drained away from the weatherproof envelope of the building so that it does not cascade onto another balcony and discharges to a lower level where the water is appropriately managed.

Where edge drainage is proposed, the following should be considered:

- The minimum finished fall should be 1:80. Design falls should take account of any potential deflection and construction tolerances. In the absence of detailed calculations, this may necessitate design falls of twice the minimum finished falls (1:40 or 2.5%). Falls should follow the same direction as the cantilever of the balcony to prevent back falls in drainage or ponding as loads are applied.
- A minimum 30mm projection of the principle water collecting surface should be present beyond the adjacent vertical surface. It should also be turned down to form a drip.
- For effective edge drainage, a linear gap is to be provided and must create at least a permanent 20mm wide opening at the leading edge. It should be continuous across the entirety of the width of the balconies leading edge. Chutes or pipes draining directly to an open area are not acceptable. Any edge draining approaches should ensure as much as practicable that drainage should not be interrupted, for example by any supporting structure or similar.
- Edge drainage should be evenly distributed.
- Balcony projections for edge drainage should be restricted to 2500mm.
- No other roofs or balconies should be designed to deliberately drain onto an edge drained balcony.
- A 6-8mm gap should be provided between each non-combustible decking board. The gaps should not create a health and safety risk to users' e.g. risk of entrapment of walking sticks, stiletto heels, or wheelchairs.
- Where decking boards are used at the pedestrian surface level, grooved decking boards should orientated to promote the shedding of water at the leading edge of the projecting balcony.
- At the base of any stack of balconies, provision for landscaping drainage must be provided as part of the design to ensure that water does not pond at ground or podium level. Paths should be avoided in areas beneath balcony stacks that utilise an edge drained approach. Where paths cannot be avoided, a suitable protection method for pedestrians should be provided.

Free drainage

Where a free draining approach is used, water is not collected on a membrane or impervious surface but allowed to dissipate through a number of perforations in the balcony substrate, meaning that any hydraulic head of water is avoided. The pedestrian surface is designed to ensure that water is not collected and stored in any way. The pedestrian surface and the water collecting surface are the same.

Where this approach is proposed:

- Balcony surfaces must be orientated to fall away from the building so that water cannot track back toward the building. Standing water is not acceptable.
- The support arms must be designed to:
 - Prevent water tracking along their underside toward the building. Where this risk is not managed, water may run down the façade, giving a greater likelihood of penetrative damp and staining.
 - Drip edge breaks in the support structure and component design to allow water to track away from the building will mitigate this risk.
- A structural upstand of not less than 75mm consisting of a fully bonded waterproof outer membrane that has 3rd party accreditation for that use is to be provided where level thresholds are required.
- A 10mm gap between the façade and pedestrian surface is to be provided to avoid run off water overly wetting the façade. Supporting bracketry connections to the main building are to be sealed so that they are weathertight to any potential moisture ingress entering the building.
- The free draining approach must meet all of the following criteria:
 - a) As-built gaps between planks or slabs should be between 6 mm to 8 mm to achieve effective drainage whilst minimizing the risk of discomfort to users with enhanced needs. This spacing must be closely controlled.
 - b) As-built gaps of 10 mm to 12 mm should be maintained around the perimeter of the pedestrian surface to facilitate good drainage and the sides of any balcony proposed must not abut the weatherproof envelope.
 - c) Where the design is to provide perforated draining, the position and sizing of the perforations or open grid should be consistently and regularly applied across the entire surface of the balcony. Openings, either perforated or linear, should provide a total free draining area of at least 5% of the overall surface area and provide a solution which ensures water is instantly dissipated from the pedestrian surface.
- Where non-combustible decking boards are used at the pedestrian surface level, grooved decking boards should be orientated to promote the shedding of water at the leading edge.
- The design should ensure that the supporting structure does not locally interfere with the drainage path or prevent free draining of the balcony area.

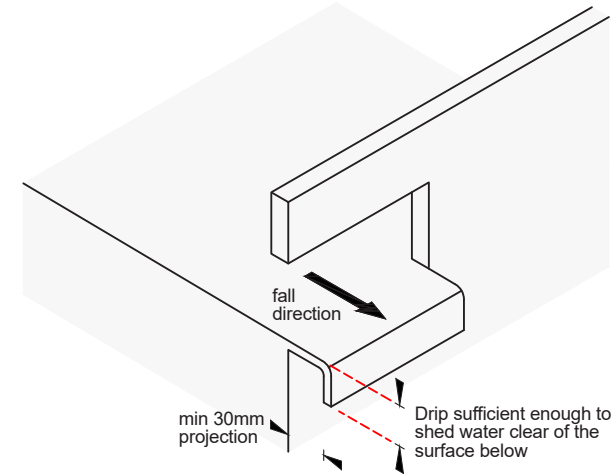
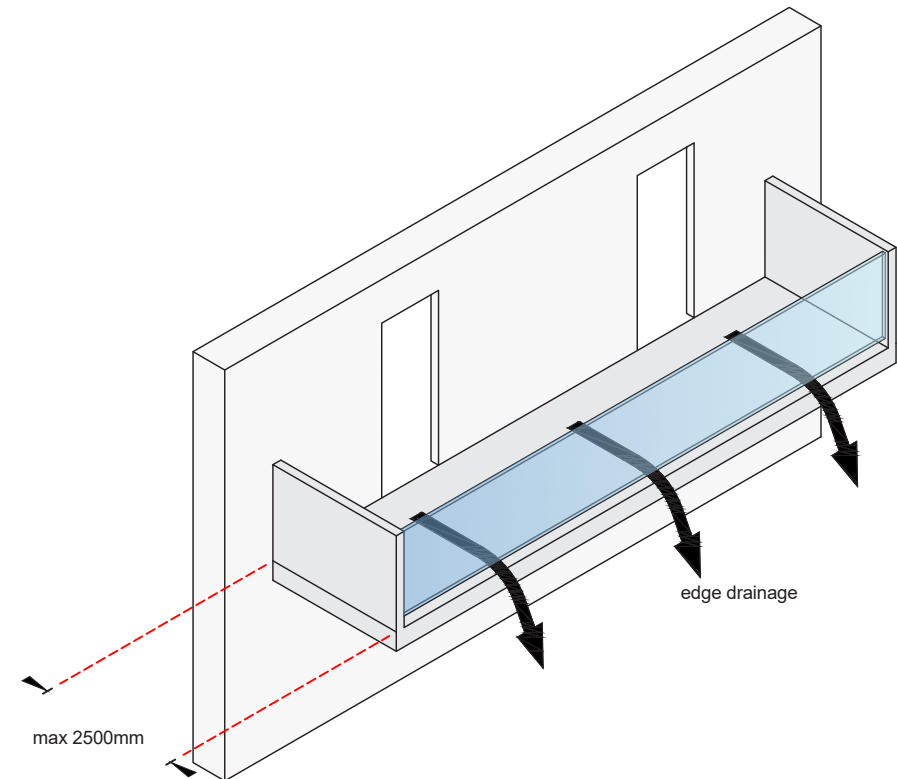
Typical edge drainage detail**Balcony projections for edge drainage should be restricted to 2500mm**

Guarding

General

Balconies to which persons have regular access other than for maintenance should be guarded to minimise the risk of falling.

General principles

The following should be considered where any type of guarding is specified:

- The guarding should meet the requirements of the relevant Building Regulations e.g. height requirements, guarding configuration requirements, etc.
- All guarding (including parapet walls and balustrading systems) should be designed in accordance with BS EN 1991-1-1 to resist horizontal loading.
- The guarding should be not prevent the balcony area from draining rainwater or overflows from functioning in the event of an outlet being blocked.

Where guarding is attached to a climbable shelf, plinth or parapet, the guarding height should be taken from the shelf, plinth or parapet.

Glazed barriers

Glazed barriers will require a nominated person to undertake a site specific design to ensure that the design of the guarding for the scheme is suitable and due diligence has been demonstrated. For glazed barriers the criteria should be satisfied by the designer:

- The barrier/glass should have sufficient strength to resist the design loads with an appropriate factor of safety.
- The displacement of the barrier, under load, should be within acceptable limits for human comfort.
- The barrier/glass should have reasonable resistance to accidental impact.
- The post-failure behaviour of the glass in a barrier should be safe and, if necessary, failed glass should retain some residual strength to preserve life safety.
- The designer should clearly demonstrate how containment of the glazing will be achieved.
- Consideration should be made for not solely relying on low level mechanical restraint into a base channel for glass infill panels. A secondary restraint fixing at high level should be considered by the designer.
- In buildings which exceed three storeys in height, 100% of toughened glazing should be formed and then heat soak tested in accordance with BS EN 14179-1. The glass must be permanently marked in accordance with BS EN 14179-1 and substantiated evidence of heat soak testing must be disclosed for all effected panes.
 - Alternatively where toughened glazing does not exceed 50kg in weight and where there is safe and easy access to remove and replace the glazing without the need for access scaffolding or fall arrest equipment, a methodology statement of how this will be undertaken should be provided.

Masonry parapet walls

Please refer to the 'External Walls – Parapets' section for guidance on the construction of masonry parapet walls.

Cavity trays and DPCs can create a slip plain that may limit the ability of the parapet wall to resist horizontal forces. The Engineer should check the structural stability of the parapet wall and appropriate steps should be taken to mitigate this risk.

Balustrading and guard rails

Balustrading and guard rails should be fixed securely to a structure which can safely resist the potential forces acting on the guarding. The durability of balustrading and guard rails should be appropriate with particular attention paid to coastal areas where corrosion resistant materials should be chosen. Please refer to 'Appendix B – Coastal Locations' for further information.

Balustrades should not be fixed through the coping or capping. Balustrades should be fixed to the face of the wall. Please refer to the 'External Walls - Parapets' section for further guidance.

Fixings for balustrades must be carefully designed to ensure appropriate fixings are robust and any penetration through waterproof roof coverings is sealed correctly in accordance with the waterproof covering manufacturer's recommendations.

Slip resistance

The surface finish of all balcony areas must have a low slip potential (in wet and dry conditions) when tested to BS 7976.

Fire considerations

In all circumstances, balconies must meet the requirements of the relevant Building Regulations. Evidence that the Building Control Body has accepted the balcony construction must be provided to the Warranty Surveyor.

Where enclosed balconies are proposed (either projecting or inset), the horizontal and vertical components separating one compartment from another is classed as a compartment wall or floor and therefore requires fire resistance from both sides (for compartment walls) and from the underside for compartment floors.

Balconies, whatever their type and construction, can have complex detailing around the junction with the external wall. The balcony and any of its components should not compromise the continuity of any cavity barriers or fire stopping. Where possible, balcony brackets that are fixed back to the inner leaf of a cavity wall should be located above or below any horizontal cavity barrier. Where this is not possible, the brackets should incorporate a means to ensure the continuity of fire separation (e.g. thermal wrapping). Any such brackets should only be used where appropriate fire test evidence is available from the manufacturer confirming it is fit for purpose. Evidence of this must be provided to the Warranty Surveyor. Manufacturers' should be consulted for specific detailing and only competent contractors should be used for its installation.

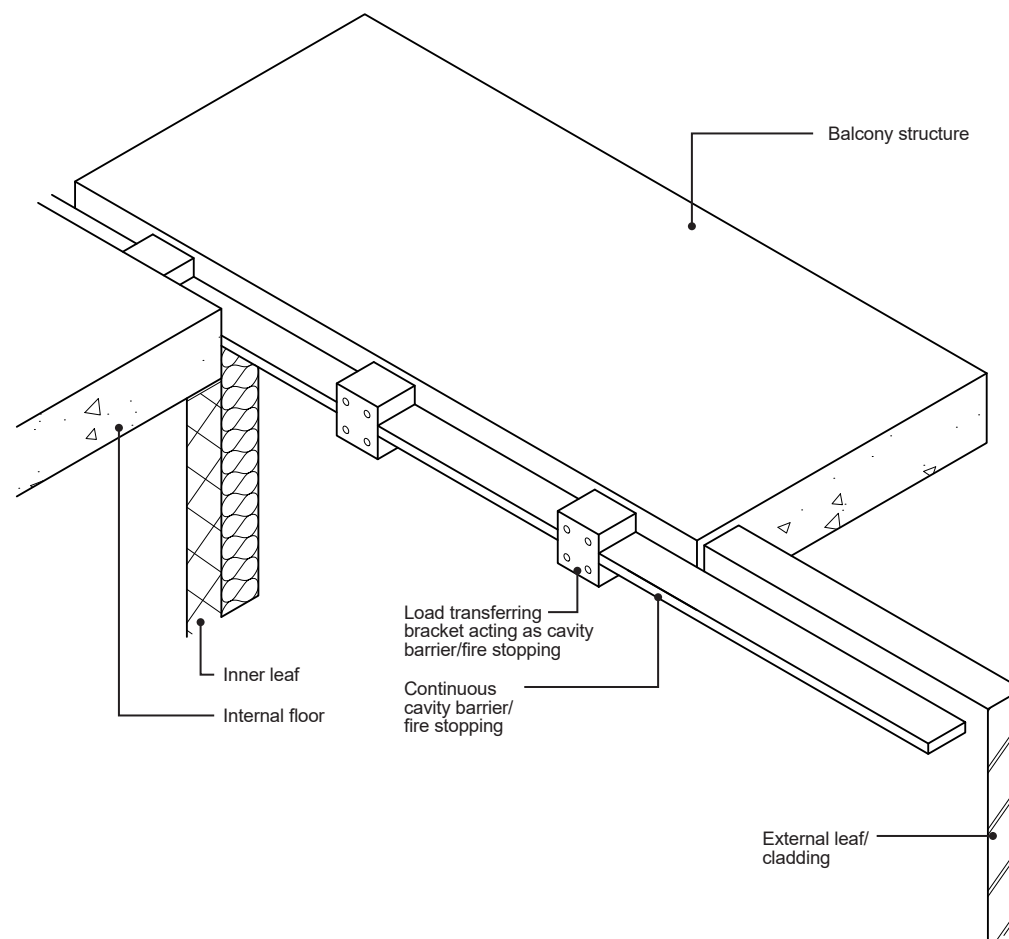

Thermal bridging and cavity trays

Care should be taken to prevent thermal bridging and any breaks in the cavity tray. Thermal breaks and cavity trays should be considered at design stage. It is the responsibility of the designer to ensure condensation risk is sufficiently mitigated.

T 0800 183 1755 **E** enquiries@labcwarranty.co.uk **labcwarranty.co.uk**



@LABC_Warranty



LABC Warranty



LABC Warranty

MD Insurance Services Ltd. is the scheme administrator for LABC Warranty and is authorised and regulated by the Financial Conduct Authority. Registered in England No: 3642459. **TS-11A-12.00-010424**

