



# TECHNICAL MANUAL

VERSION 10

# 12.

## Balconies and Terraces

### Contents

Functional Requirements

12.1 Forming a Roof

## ADDITIONAL FUNCTIONAL REQUIREMENTS

### Limitations of these Functional Requirements

1. These Functional Requirements are limited to Balconies and Terraces which form a roof only.

### Workmanship

1. A roof membrane manufacturer's approved installer must be used for all balcony/terrace coverings.
2. Balcony/terrace roof membranes will be required to be weather and waterproof and, in certain circumstances the flat roof covering will also require to be tested at completion.

### Materials

No additional requirements.

### Design

1. Balcony/terrace roof structures and coverings, shall be designed and constructed so that they:
  - a. Are structurally sound;
  - b. Satisfactorily resist the passage of moisture due to rain and snow to the inside of the building, and to materials which might be adversely affected by such moisture;
  - c. Have an adequate thermal performance;
  - d. Have adequate resistance to fire penetration and the spread of flame across their external surfaces;
  - e. Do not allow fire spread across the tops of separating walls;
  - f. Adequately discharge rainwater from the roof area to a suitable drainage system.
2. In addition to point 1: shall, unless specifically agreed otherwise with the Warranty provider, comply with the requirements of BS 6229 and be designed to have a minimum finished fall of 1 in 80.
3. Balconies and Terraces must have appropriate guarding meeting the requirements of Building Regulations.
4. For warranty purposes, flat cold deck balcony terrace roofs are not acceptable.

# **12.**

## **Balconies and Terraces**

### **12.1**

#### **Forming a Roof**

### Introduction

This section provides specific advice and requirements in respect of balconies and terraces, where the balcony or terrace forms part of the roof or forms the entire roof to other occupied parts of a building and is warm deck construction.

### Design

#### Selection of system type

The cold deck roof system is not permitted on balconies or terraces that form part of the roof to other occupied parts of the building. In these circumstances the selection of system type (warm deck or inverted warm deck) should be based upon the following criteria;

- Roof zone depth (height from ceiling to termination of waterproofing).
- Likely point loading.
- Construction process (a complete inverted warm deck roof, with suitable protection and which may be suitable for storage or access by other trades, a warm deck roof may not be suitable for storing heavy loads).

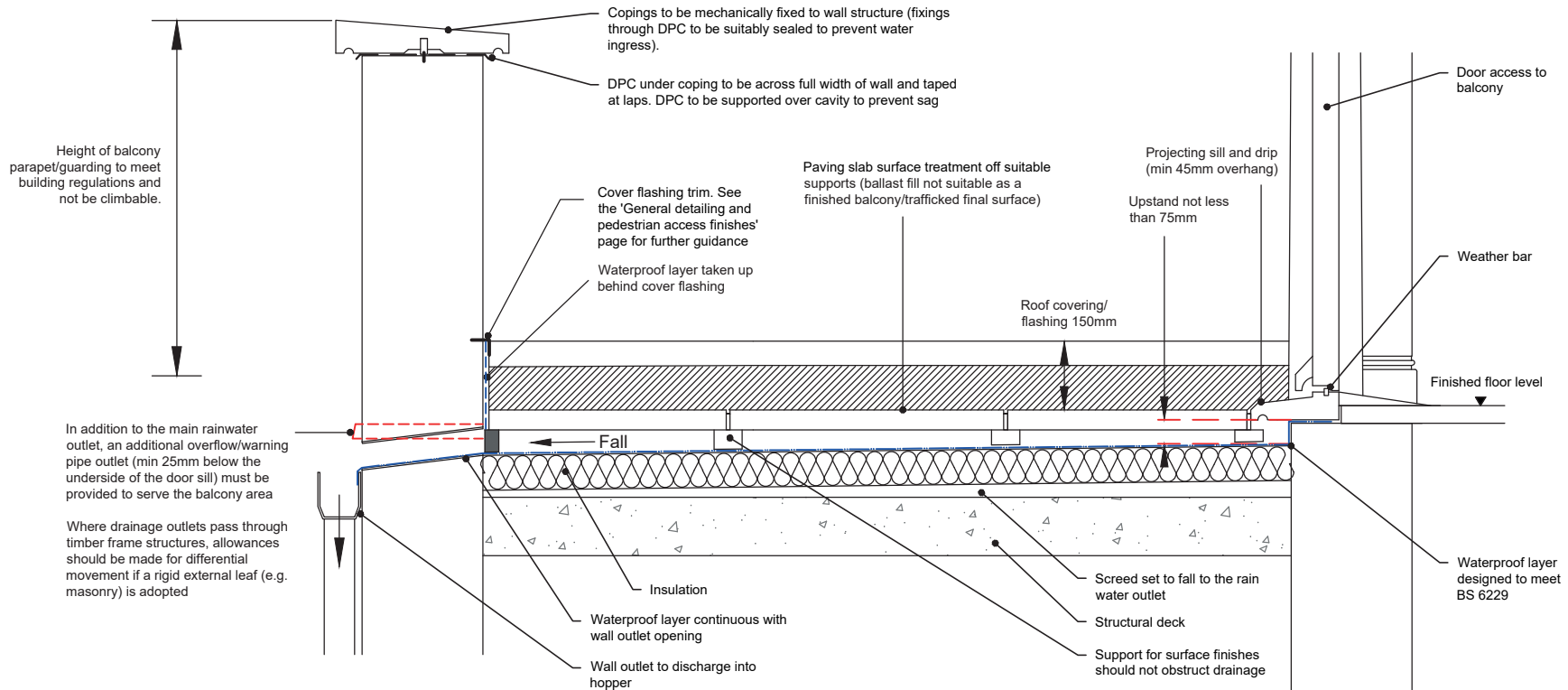

### Notes

- Insulation above structural deck and waterproof layer to be XPS insulation suitable for weight of surface treatment.
- Waterproof membrane must be laid to a fall - to a suitable outlet. All joints formed must be sealed in accordance with the manufacturers requirements and not result in water being trapped/ponding.
- Membrane not to be laid in air temperatures less than 5°C.
- Where structural deck is constructed over accommodation below the design, construction should meet sound insulation requirements.
- Structural deck to be an engineered design for the loading/intended use.
- A spreader plate will be required to protect the insulation under paving supports to spread loads to prevent sag and ponding.

## Introduction

This section provides specific advice and requirements in respect of balconies and terraces where the balcony or terrace forms part of the roof or forms the entire roof to other occupied parts of a building and is inverted warm deck construction.

## Design

### Selection of system type

The cold deck roof system is not permitted on balconies or terraces that form part of the roof to other occupied parts of the building. In these circumstances the selection of system type (warm deck or inverted warm deck) should be based upon the following criteria;

- Roof zone depth (height from ceiling to termination of waterproofing).
- Likely point loading.
- Construction process (a complete inverted warm deck roof, with suitable protection and which may be suitable for storage or access by other trades, a warm deck roof may not be suitable for storing heavy loads).

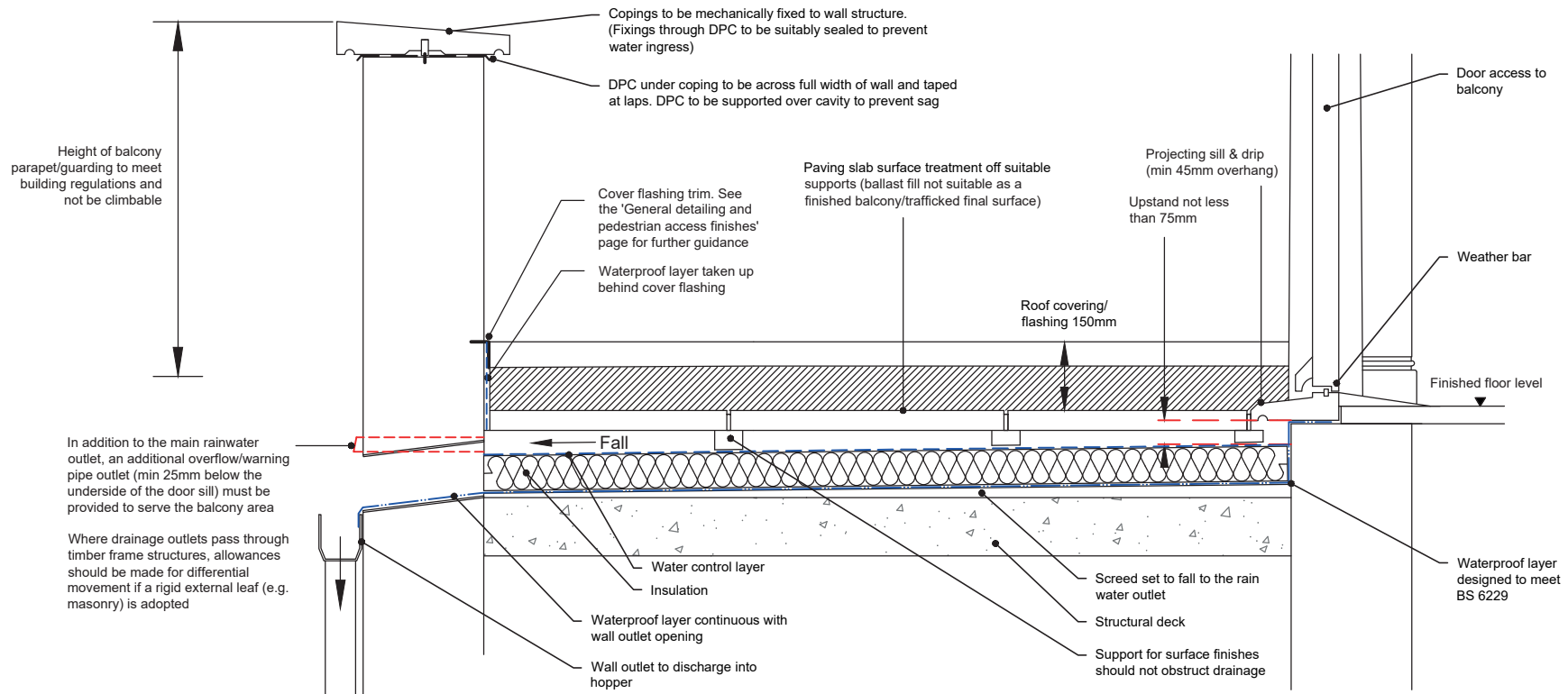

## Notes

- Insulation above structural deck and waterproof layer to be XPS insulation suitable for weight of surface treatment.
- Waterproof membrane must be laid to a fall - to a suitable outlet. All joints formed must be sealed in accordance with the manufacturers requirements and not result in water being trapped/ponding.
- Membrane not to be laid in air temperatures less than 5°C.
- Where structural deck is constructed over accommodation below the design, construction should meet sound insulation requirements.
- Structural deck to be an engineered design for the loading/intended use.
- A spreader plate will be required to protect the insulation under paving supports to spread loads to prevent sag and ponding.

## Definitions

For the purposes of this Technical Guidance, the following definitions shall apply:

**Condensation:** process whereby water is deposited from air containing water vapour when its temperature drops to or below dew point.

**Filter layer:** construction material (usually a geotextile) that substantially reduces the transfer of mineral and organic material to the insulation in an inverted warm deck roof.

**Flat roof:** a roof having a pitch no greater than 10° to the horizontal.

**Insulation cricket:** wedge of shallow-fall insulation material, designed to divert the flow of rainwater on a roof.

**Interstitial condensation:** condensation occurring within or between the layers of the building envelope.

**Protection layer:** construction material (usually a geotextile all rigid board) that isolates another construction material from mechanical damage.

**Separation layer:** construction material (usually a geotextile) that separates two construction materials that are not chemically compatible.

**Structural deck:** continuous layer of the construction (comprising concrete, profiled metal or timber panel) supported by the building structure and which supports the roof system.

**Thermal bridge:** part of a roof of lower thermal resistance than its surrounding elements, which may result in localised cold surfaces on which condensation, mould growth or staining may occur.

**Air vapour control layer (AVCL):** construction material (usually a membrane) that substantially reduces the movement of water vapour through the roof system.

**Water control membrane (WCM):** construction material (usually a sheet membrane) that substantially reduces the transfer of rain water to the insulation in an inverted warm deck roof.

## Warm deck roof

The principal thermal insulation is placed immediately below the roof covering, resulting in the structural deck and support being at a temperature close to that of the interior of the building.

The design should ensure that:

- The waterproof membrane has sufficient resistance to temperature to suit the conditions created by a substrate of insulation.
- The insulation has sufficient mechanical characteristics to resist loading.
- The AVCL is provided by the deck or by a membrane placed above the deck.
- The structural deck is maintained at a temperature above that which could cause condensation to occur at this level during service.

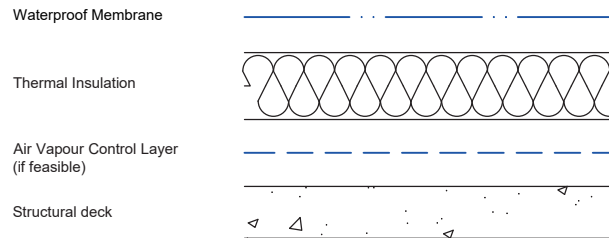

## Inverted warm deck roof

A variant of the warm deck roof in which the principal thermal insulation is placed above the waterproof membrane, resulting in the waterproof membrane, structural deck and structural support being at a temperature close to that of the interior of the building. Generally, the principal insulation is secured by separate ballast (paving or stone).

A filter membrane or WCM should be provided to control mineral and organic material passing into and below the insulation joints. A WCM is recommended because it will provide improved rain water run off, which may allow for a reduced thickness of insulation and reduced loading of ballast. If a WCM is included, it is essential that the drainage design facilitates the rapid transfer of rain water across the product and to rain water outlets.

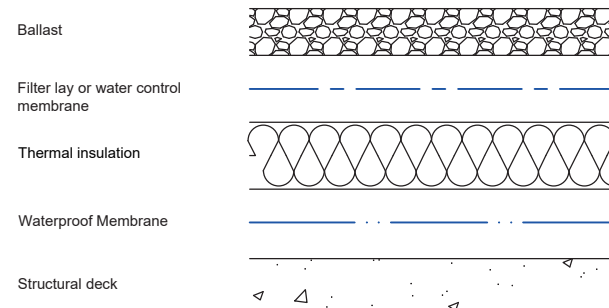

## Hybrid roof

Many roofs combine the features of two or more of the roof types previously described. Examples include structural decks of high thermal resistance combined with additional insulation, and existing roofs to which thermal insulation is added. Once assessed in terms of their thermal and water vapour transmission characteristics, such roofs will generally fall into one of the categories described.

In some constructions, the waterproof membrane is placed between two layers of insulation, combining the properties of warm roof and inverted warm roof construction. This form of construction is generally known as a 'duo roof'.

There is an increased risk of interstitial condensation with a hybrid roof and therefore where these types of roof systems are used a full condensation risk analysis should be carried out.

## Cold deck roof

The cold deck roof system is not permitted on balconies or terraces that form part of the roof to other occupied parts of the building.

In these circumstances an alternative roof system should be adopted.

## Structure General

The design and construction of flat roofs should be in accordance with BS 6229 - Flat roofs with continuously supported flexible waterproof coverings - Code of practice states and the relevant euro codes. The following is adapted from BS 6229 - Flat roofs with continuously supported flexible waterproof coverings - Code of practice states:

### Structure

The roof structure should be designed for strength and stiffness in accordance with the Code of Practice for the relevant structural material.

Dead and imposed loads upon a roof should be assessed in accordance with BS EN 1991-1-1 + UK National Annex, taking due consideration of any added surfacing; paving slabs, gravel etc. Snow loads should be assessed in accordance with BS EN 1991-1-3 + UK National Annex. Wind loads should be assessed in accordance with BS EN 1991-1-4:2005 + A1:2010 + UK National Annex.

Relevant structural material on roof structure strength and stiffness should be assessed in accordance with BS EN 1992-1-1, BS EN 1993-1-1, BS EN 1994-1-1, BS EN 1995-1-1, BS EN 1999-1-1 and their UK National Annexes.

The resistance to wind uplift of the waterproof covering and finishes on a flat roof should be assessed having regard to the dead weight of those materials and to the nature, type and disposition of their attachment to the slab or deck, in accordance with BS 8217 and BS EN 16002.

Whilst a roof slab should be regarded as airtight and where the critical layer is the exposed roof surface, be it the waterproofing, or inverted insulation system, a roof deck might be regarded as air permeable and likely to allow internal air pressures to impinge on the roof system from below.

Wind uplift pressure, in an air-permeable deck, is exerted on the underside of any layer of the construction which is substantially air-impermeable, such as the vapour control layer or the waterproof layer; this pressure, less the appropriate dead weight, should be resisted by adequate mechanical or bonded connections between the air impermeable layer and the deck.

The roof design should take account of possible differential movements within the slab/deck and at junctions with supporting structure, parapets, kerbs and upstands.

Note: Such movements might be caused by movement of the structural frame or by changes of temperature and moisture content.

### Limitations of this guidance

The guidance on timber structures is limited to not more than three storeys above ground.

### Loading

#### Balcony/Terrace structure and loading

The design of the roof structure must be in accordance with current regional Building Regulations.

The balcony/terrace of the building shall be constructed so that the combined dead, imposed and wind loads are sustained and transmitted by it to the ground safely, and without causing such deflection or deformation of any part of the building, or such movement of the ground, as to impair the stability of any part of another building.

The roof structure should be of such construction that it has adequate interconnection with the walls, allowing it to act as a horizontal diaphragm capable of transferring the wind forces to buttressing elements of the building.

If joists are spanning intermediate beams it is important that the joists are fixed to these beams it is important that this is carried out in accordance with the Structural Engineers specification.

The Designer must establish the intended loadings expected on the balcony/terrace including loads from finishing surfaces such as paving slabs and/ or ballast as well as any potential planting.

Fixings for balustrades must be carefully designed to ensure appropriate fixings are robust and any penetration through waterproof roof coverings are sealed correctly in accordance with the waterproof covering manufacturer's recommendations. Such fixings should not be made through to a wood substrate but to the masonry structure e.g. wooden plates or packing pieces must not be used under the waterproof membrane to secure the balustrade too.

The design of the terrace/balcony should be designed by a suitably qualified Structural Engineer in accordance with BS EN 1995-1: Eurocode 5 design of timber structures. General. Common rules and rules for buildings.

It is important that the deck have adequate provision to resist wind uplift by being adequately anchored to the main structure.

#### Allowances for wind loading

In all situations, including ballasted and inverted roofs, a calculation of wind load at each zone of the roof to BS EN 1991-1-4 should be undertaken by a suitably competent person. Wind load acting on a balcony will be affected significantly by the design of the perimeter and by the geometry and finishes on the elevations of the building. Any changes to these elements will necessitate a review of the calculation output. It is important to ensure that the balcony/terrace is securely fixed to the main structure in accordance with the Structural Engineers design.

#### Resistance to imposed loads

At the earliest possible stage the employer should define the range of potential imposed loads for which the balcony is to be designed such as planters, storage and public access. In the absence of such a performance requirement the loading limits of the balcony should be defined.

### Structural timber

All structural timber used should be stress graded. All such timber must be stamped as either 'DRY' or 'KD' (Kiln Dry). The use of ungraded, or 'green', timber is not acceptable.

### Treatment of timber

Preservative treatment of roof timbers is normally unnecessary, except where specifically required under relevant standards and Codes of Practice. Further information can be found in 'Appendix C - Materials, Products, and Building Systems'.

### Structural deck

#### General

At the earliest practical stage, the likely deflection of the deck should be confirmed, to ensure a minimum 1:80 as built fall is maintained. If the deck is intended to receive mechanical fasteners for the attachment of roof system components such as insulation, or equipment such as fall-arrest line posts, its resistance to pull-out should also be confirmed to enable design for resistance to wind load.

Structural decks should be suitable of supporting the intended loads.

The structural deck should be designed by a suitable qualified Structural Engineer. It is important to ensure that the structural deck is installed and fixed in accordance with the Structural Engineer's design.

#### Insulation of warm decks

The insulation should be suitably specified taking into account the roof type, having regard to its load-bearing capacity and, where relevant, its water absorption characteristics. Compressible materials cannot support imposed loads and are not suitable in warm deck roofs. Warm roofs require the use of rigid insulation, and should be suitably specified to support the any anticipated loads from trafficking across the roof. Insulation in an inverted roof should also have high resistance to water absorption, freeze/thaw cycling and be shielded from UV light.

#### Composite panels (deck/vapour control/insulation)

The suitability of composite panels in providing a combined deck, AVCL and thermal insulation in a single component should be assessed with reference to the loading and hygrothermal conditions in the application. There is no relevant hEN or British Standard. Products suitable for roofing should have current certification by one of the following:

- British Board of Agrément.
- Another member of the UEAtc.
- Another notified body.

#### Typical warm deck construction

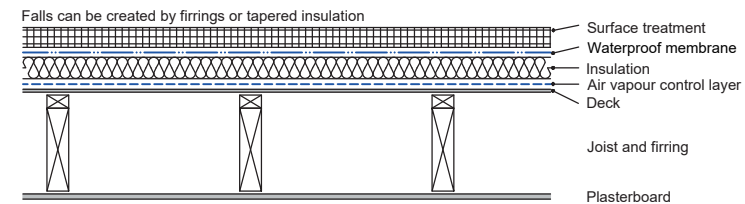

#### Typical inverted warm deck construction

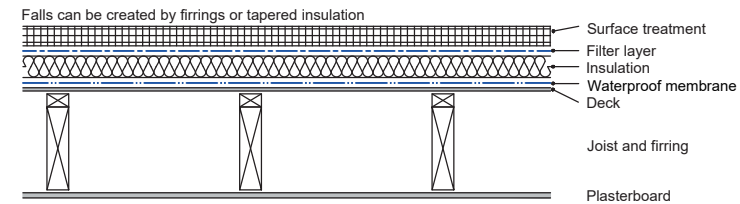



Typical warm deck construction

Note: Permanent waterproofing should not be installed until the deck has fully dried

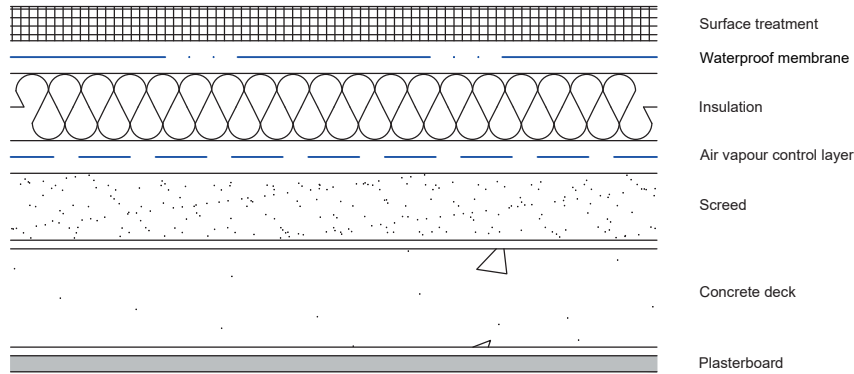

Typical inverted warm deck construction

Note: Permanent waterproofing should not be installed until the deck has fully dried

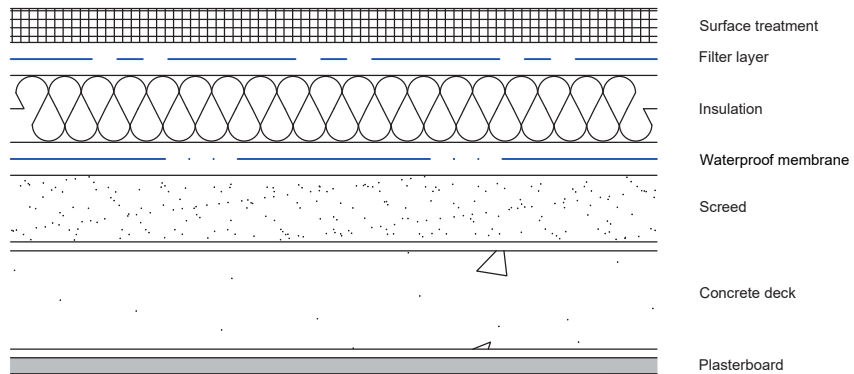

For in situ concrete decks it is important that:

- The form work is adequately and accurately constructed.
- The mix should be one that has relatively low shrinkage characteristics.
- The slab should be adequately protected until cured.

Pre cast concrete decks should:

- Have a minimum of 90mm bearing unless justified by the design.
- Be grouted in accordance with the design, and
- Allowance for movement should be provided at abutments.

Balcony/terrace loading

**Statutory requirement**

The design for loading should comply with the current Building Regulations.

**Resistance to wind load**

In all situations, including ballasted and inverted roofs, a calculation of wind load at each zone of the roof to BS EN 1991-1-4 should be undertaken by a suitably competent person.

Wind load acting on a balcony will be affected significantly by the design of the perimeter and by the geometry and finishes on the elevations of the building. Any changes to these elements will necessitate a review of the calculation output.

It is important that the deck have adequate provisions to resist wind uplift by either being of sufficient self weight or adequately anchored to the main structure.

**Resistance to imposed loads**

At the earliest possible stage the designer should define the range of potential imposed loads for which the balcony is to be designed such as planters, storage and public access. In the absence of such a performance requirement the loading limits of the balcony should be defined.

Structural deck

**General**

At the earliest practical stage, the likely deflection in the deck, and the tolerance in the level of its finish, should be confirmed, because this informs the design for drainage. If the deck is intended to receive mechanical fasteners for the attachment of roof system components such as insulation, or equipment such as fall-arrest line posts, its resistance to pull-out should also be confirmed to enable design for resistance to wind load.

**Concrete**

Precast concrete construction should be designed in accordance with BS 8110. Information on span capability and the installation requirements of precast panels can be obtained from manufacturers. Information on the location of required movement joints should be obtained early in the design process as they have implications for drainage layout and detailing. Precast panels installed to a fall can provide a simple layout but without cross falls.

In-situ concrete construction should be designed in accordance with BS 8110. Concrete decks should be laid to falls wherever possible, concrete may be more difficult to lay to a fall, and it is common to create falls in the insulation (warm roofs only) or by using an additional screed. Information on compressive strength, resistance to point load and drying periods of wet screeds can be obtained from suppliers and relevant trade associations.

Where structural movement joints are required in large concrete decks, a clearly defined movement joint detail should be constructed to a design and with the materials that afford durability equivalent to that of the roof system.

In precast panel decks the locations of any anticipated differential movement e.g. at perimeter or abutment interfaces or between adjacent panels that are subject to differential loading, must be identified in order that stress is not transferred to the waterproof membrane.

Screeds

Screeds should be suitably specified for the anticipated loadings, further information can be found in 'Appendix C - Materials, Products, and Building Systems'. Moisture from the construction can become trapped in a roof if the waterproof layer is applied before a concrete slab or screed has had sufficient time to dry out. In situ concrete slabs and cementitious screeds contain large volumes of water which, if not allowed to dry out, can prevent adhesion of the waterproof layer. If bonding to the slab, it is advised that an adhesion test be carried out.

Insulation of warm decks

The insulation should be suitably specified taking into account the roof type, having regard to its load-bearing capacity and, where relevant, its water absorption characteristics. Compressible materials cannot support imposed loads and are not suitable in warm decks. Warm roofs require the use of rigid insulation, and should be suitably specified to support the any anticipated loads from trafficking across the roof. Insulation in an inverted roof should also have high resistance to water absorption, freeze/thaw cycling and be shielded from UV light.

Typical deck construction (warm roof)

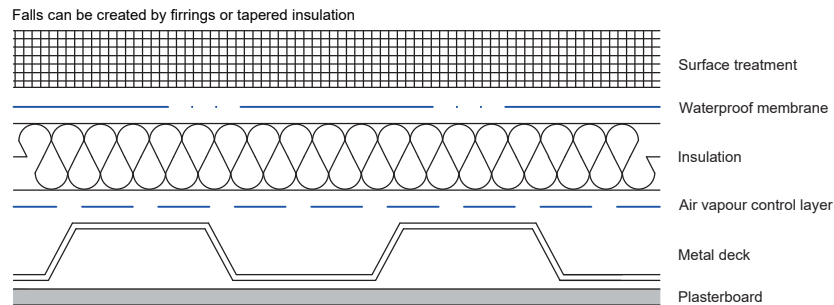

Typical inverted warm deck construction

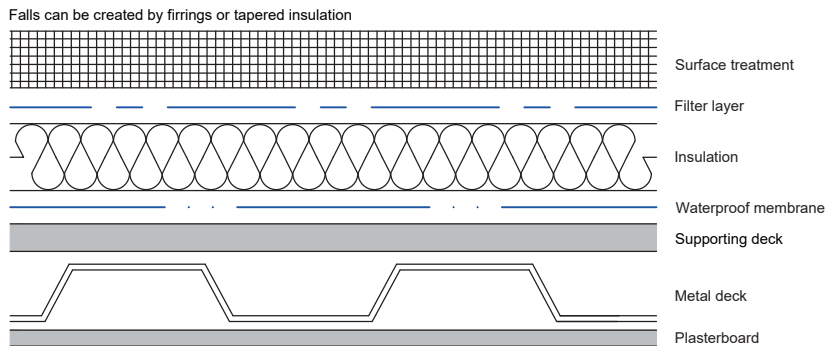

Loading

Statutory requirement

The design for loading should comply with the current Building Regulations.

Resistance to wind load

In all situations, including ballasted and inverted roofs, a calculation of wind load at each zone of the roof to BS EN 1991-1-4 should be undertaken by a suitably competent person.

1991-1-4 should be undertaken by a suitably competent person.

Wind load acting on a balcony will be affected significantly by the design of the perimeter and by the geometry and finishes on the elevations of the building. Any changes to these elements will necessitate a review of the calculation output.

Resistance to imposed loads

At the earliest possible stage the employer should define the range of potential imposed loads for which the balcony is to be designed such as planters, storage and public access. In the absence of such a performance requirement the loading limits of the balcony should be defined.

Insulation of warm decks

The insulation should be suitably specified taking into account the roof type, having regard to its load-bearing capacity and, where relevant, its water absorption characteristics. Compressible materials cannot support imposed loads and are not suitable in warm decks. Warm roofs require the use of rigid insulation, and should be suitably specified to support the any anticipated loads from trafficking across the roof. Insulation in an inverted roof should also have high resistance to water absorption, freeze/thaw cycling and be shielded from UV light.

Structural deck

General

At the earliest practical stage, the likely deflection in the deck, and the tolerance in the level of its finish, should be confirmed, because this informs the design for drainage. If the deck is intended to receive mechanical fasteners for the attachment of roof system components such as insulation, or equipment such as fall-arrest line posts, its resistance to pull-out should also be confirmed to enable design for resistance to wind load.

Profiled metal (steel or aluminium)

Profiled metal decks should have a crown width at least 50% of the profile width. To provide a sound base for the insulation and waterproofing system, and to avoid reduced drainage performance, the mid-span deflection of the metal deck should not exceed 1/200 of the span under uniformly distributed design loads. When considering the deck profile and the necessity for side lap stitching and metal deck closures, reference should be made to the manufacturers of the deck, insulation and waterproof membrane.

Profiled metal decks: critical dimensions

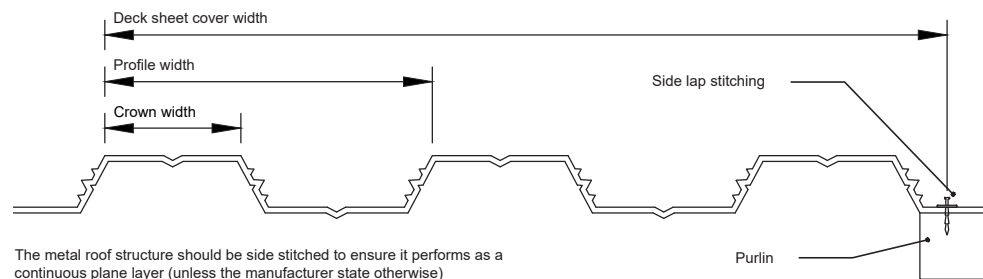

The metal roof structure should be side stitched to ensure it performs as a continuous plane layer (unless the manufacturer state otherwise)

Profiled metal decks should conform to the following standards:

- Galvanised steel: minimum recommended thickness 0.7mm to BS EN 10346 Fe E280G Z275. Typical gauge range 0.7mm-1.2mm.
- Plain aluminium: minimum recommended thickness 0.9mm to BS EN 485-2 AA3004 H34. Reference should also be made to BS EN 1396 as appropriate.

It is important that the deck have adequate provisions to resist wind uplift by being adequately anchored to the main structure.

## Thermal performance

Design for thermal performance must comply with current regional Building Regulations, as appropriate.

## Thermal insulation

The thermal insulation should be selected with regard to the following minimum criteria:

- Thermal insulation components are to have third party product approval confirming suitability for use in proposed situation.
- Thermal resistance (and therefore thickness) to suit minimum clearances at details.
- Resistance to compression and point loads from surface finishes/supports.
- Compatibility with the AVCL and waterproof membrane.
- Compatibility with adhesives (if insulation is adhered).
- Contribution to the external fire performance of the system.
- Acoustic properties: resistance to external sound is not currently regulated. However, there may be a need to consider attenuation from balconies.
- A spreader plate will be required to protect the insulation under paving supports to spread loads to prevent sag and ponding.

Note: The alternative of a separate acoustic attenuation layer should be considered where appropriate.

## Thermal transmittance

Design for thermal transmittance should take account of the effect of thermal bridging within the roof field and at interfaces between the roof system and adjoining elements, such as parapet walls or abutments.

In particular, allowance should be made for the effect of:

- Thermal bridging by metal fasteners used to secure insulation and/or membrane. Thermal break telescopic tube fasteners are recommended to avoid this.
- Thermal bridging due to drainage of rain water or snow-melt through insulation in inverted roofs. The use of a WCM beneath ballast to reduce thermal bridging is recommended.
- The locations of above average thermal transmittance at sumps, gutters or areas of minimum thickness of tapered insulation.

Manufacturers of thermal insulation and WCMs provide certification and calculations of the effects of thermal bridging by fasteners and drainage respectively. Further advice is available in Building Research Establishment BR 262 Thermal insulation: avoiding risks.

## Installation of thermal insulation

The attachment of the thermal insulation should be designed to resist calculated wind load by a declared margin of safety. This includes consideration of dead loads required in all roof zones in ballasted warm roofs and inverted warm roofs.

## Air permeability

Relevant contract drawings should define the position of the component - the air barrier - that determines resistance to air permeability. This may be achieved by an additional, purpose designed membrane or by an additional function of another component, such as the deck or waterproof membrane.

## Control of condensation

Any provision required to control interstitial condensation within the roof should be determined to the calculation method defined by BS 5250, but with ambient conditions set in BS 6229. The calculated maximum accumulation of moisture within thermal insulation should not exceed 350g/m<sup>2</sup> and there shall be no net accumulation in any annual cycle.

## Air vapour control layer (AVCL)

The AVCL should be selected with regard to the following minimum criteria:

- Ease with which it can be sealed at laps and at abutments to other elements.
- The method of attachment.
- Condensation risk, expressed as calculated vapour pressure based on notional conditions pertaining to the project building.
- Compatibility with the waterproof membrane and thermal insulation.

The following is a minimum recommended specification. The actual specification will depend on the level of vapour resistance required, based on calculation, and the type of deck.

The attachment of the AVCL should be designed to resist calculated wind load by a declared margin of safety. All laps should be sealed and the AVCL should be sealed to the adjoining element, which forms the continuation of the resistance to air permeability. The AVCL should be extended behind all thermal insulation, including insulation placed on vertical surfaces such as parapet walls. Where the roof system is penetrated by a detail such as a pipe or duct, a suitable method for providing continuous vapour control should be provided, and this method should be followed in practice.

Where a reinforced bitumen membrane AVCL is used, its installation should be in accordance with BS 8217.

## Minimum recommended specification for AVCL for warm deck roofs

Roof system type	Deck type	AVCL	Attachment
Reinforced bitumen <sup>(1)</sup> membrane	Profiled metal	S2P3 <sup>(2)</sup>	Partial bond by 3G or approved proprietary alternative
	Concrete	S2P3	Fully bonded
	Timber panel	S2P3	Partial bond by 3G or approved proprietary alternative
High density polyethylene	All	200µ	Loose laid beneath mechanically fixed insulation
High density polyethylene and metal foil laminate	As per certification	Proprietary	Fully bonded to prepared substrate all as per manufacturer's instructions
Coated metal foil laminate - self-adhesive	As per certification	Proprietary	Fully bonded to prepared substrate all as per manufacturer's instructions
Notes: (1) Reinforced bitumen membranes: minimum recommended specification based on classification in BS 8747. (2) S and P are classifications 1-5 of Strength (tensile strength and elongation) and resistance to puncture (static and dynamic); the higher the rating, the higher the performance.			

## Falls and drainage

### Statutory requirement

Design for drainage of the flat roof covering should comply with the current Regional Building Regulations.

### British and industry standards

The requirements of BS 6229 should prevail in respect of balconies and terraces, whether or not they form part or the entire roof to occupied parts of a building, and irrespective of the type of waterproof membrane.

Wherever practical, balconies, terraces, and podium decks should be designed to fall away from the building elevation. If this is not practical for reasons of continuity of rainwater services, the falls should be arranged across the balcony, parallel to the elevation.

BS 6229 states that a minimum finished fall at any point of 1:80 (1.25%) should be achieved.

Since adjoining roof planes at 1:80 will meet at a mitre of less than 1:80, the intended finished fall at such intersections should be considered at an early stage.

Design falls should take account of any potential deflection and construction tolerances. In the absence of detailed calculations, this may necessitate design falls of twice the minimum finished falls (1:40 or 2.5%).

Cut-to-falls systems are often produced to a 1:60 (1.7%) fall or 1:40 (2.5%) fall. However the use of these systems does not remove the need to check that deck deflection and tolerance is overcome and that a resulting fall in the waterproof membrane of a minimum of 1:80 is achieved. Allowance for deflection is particularly important in designing inverted roofs where calculation of dead loading should be based upon the ballast type and depth to be used.

The manufacturers of certain waterproofing products have certification for their use in 'completely flat' or 'zero falls' applications. For the purposes of this standard the design conditions of BS 6229 shall be assumed to prevail in all balcony/terrace situations.

Consideration should also be given to:

- The available upstand height at the high end of the falls. This may be a limiting factor on the length/size of the balcony/terrace area to be drained. If necessary additional rainwater outlets should be provided.
- Avoidance of ponding behind wide obstructions to the drained slope such as plant plinths or roof lights. Additional rainwater outlets and/or insulation crickets should be provided.
- Avoidance of gutters by designing with intersecting roof planes.
- Falls between rain water outlets along a perimeter.

Since the primary function of the roof is to exclude water, it is important to consider how best to direct this into the drainage system.

Ponding on membrane roofs should be avoided because:

- It encourages the deposit of dirt and leaves, which can be unsightly, may obstruct outlets and/or become a slip hazard.
- In the event of damage, the interior will suffer increased water ingress.
- The load may cause progressive deflection of the deck.
- Ice or algae may create a slip or wind hazard, particularly on walkways.

Independent research has shown that roofs with extensive ponding require increased maintenance input.

Waterproof coverings of all types are tested for water absorption and water tightness as part of third-party certification. However, the construction process, including the installation of components and the forming of seams, is clearly facilitated in dry, well-drained conditions.

Note: Rainwater outlets and downpipes can constitute thermal bridges which may increase the risk of localized condensation; an assessment might be required to determine whether insulated outlets are to be used.

### Creation of falls

Roof falls may either be created during the construction of the deck or alternatively by using tapered insulation systems (warm deck systems only).

The creation of falls in the deck should always be attempted because it has the following advantages:

- There will be a consistent thermal environment across the roof.
- The AVCL will also be to a fall.
- If mechanical fasteners are to be used for the waterproof membrane, their length will be constant, which facilitates planning and installation.

Cementitious screeds provide a stable substrate to mitred falls with minimal tolerances, and are recommended. Screeds should be in accordance with BS 8204. Lightweight screeds should be overlaid with a 1:6 (cement to sand) screed topping of a minimum 10mm thickness.

Tapered insulation schemes, suitable for warm deck roofs only, have the following advantages:

- It is possible to create effective drainage layouts to complex plan areas.
- Mitred falls can be created easily to direct rain water to single points where outlets are to be located.

Where falls are created by tapered insulation, the design should ensure that the average U-value and maximum U-value at any point, required by SBEM or SAP calculation, is achieved.

Where the roof finish is to include paving on supports, consideration should be given to the height difference created by the falls and spacing of rainwater outlets so that the maximum height of paving supports is not exceeded, the minimum height of upstands is not affected or trip hazards created. On large balconies and terraces it may be necessary to increase the number of outlets in order to reduce maximum roof zone depth.

### Drainage

Drainage design should be based upon calculations in accordance with BS EN 12056 Part 3 given a design head of water (typically 30mm). Rain water outlet capacity should be taken from properly certificated information provided by manufacturers, and the resulting number and layout of outlets should allow for obstruction and drag due to any additional surface finishes, such as walkways. The drainage above the waterproof covering and below any raised decking finishes must not be restricted or blocked by the decking supports. The decking supports must allow free drainage of all areas of the roof to the designated outlets.

The drainage above the waterproof covering and below any raised decking finishes must not be restricted or blocked by the decking supports. The decking supports must allow free drainage of all areas of the roof to the designated outlets.

- Rainwater outlets should be readily accessible without disruption to the pedestrian finish. On finishes raised above the waterproof membrane (warm deck roofs) or Water Control Membrane (inverted roofs), this may be achieved by a suitably marked paving slab or demountable section of decking.
- Where rainwater downpipes from other higher roof areas or balconies discharge via a lower balcony or terrace, an open downpipe shoe is not permitted. The downpipe should be connected directly to the downpipe serving the lower balcony or terrace.

### Rainwater outlets

The following should be confirmed by reference to the manufacturer's information or independent certification, as appropriate:

- Capacity in litres per second at a range of typical water heads.
- Compatibility with the waterproof membrane.
- Integral insulation to avoid condensation.
- Method of attachment.
- Rainwater outlets for inverted roofs should be of the dual height type, designed to maximise removal of rainwater at WCM level.

Roofs which drain to a single internal outlet or combined outlets connected into a single downpipe should be provided with an overflow to drain and warn of outlet/downpipe blockage and so avoid the risk of flooding. The capacity of the overflow should be not less than that of the outlet or combined outlets and its discharge should be visible but directed away from the building. Over flows should be positioned as close to the outlets as possible to avoid rainwater build up on roofs.

### Overflows

Roofs which drain to a single internal outlet or combined outlets connected into a single downpipe, should be provided with an overflow to drain and warn of outlet/downpipe blockage and so avoid the risk of flooding. The capacity of the overflow should be not less than that of the outlet or combined outlets and its discharge should be visible but directed away from the building. Over flows should be positioned as close to the outlets as possible to avoid rainwater build up on roofs.

If a balcony is served by a single rainwater outlet, an overflow facility of equivalent capacity and clearly visible externally should be provided at or near the same location, no more than 50mm above the level of the waterproof membrane and a minimum of 25mm below any thresholds.

## Box gutters

It is not generally necessary to provide separate box gutters where two planes of roofing intersect, or where a single plane falls to an abutment. In the latter case, there will be no fall between outlets, so consideration should be given to creating these in the structure or insulation. Box gutters are slow, difficult to construct and introduce unnecessary complexity. The need to maintain a fall in gutters and comply with the energy requirements of the Building Regulations may be difficult to achieve.

## Drainage layout options

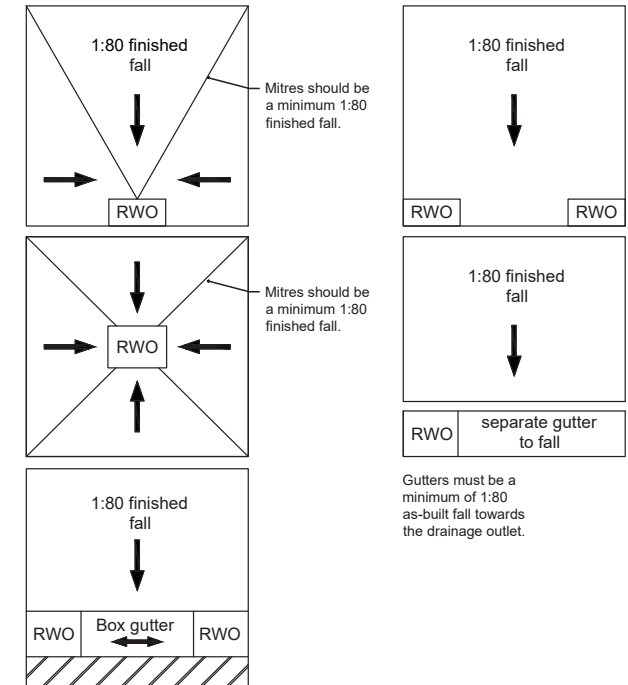

## Siphonic drainage

All waterproof membranes are compatible with siphonic roof drainage systems, which for larger roofs offer many advantages:

- Very high capacity, enabling fewer outlets and therefore less detailing work on-site.
- Smaller bore horizontal collector pipework, enabling reduced roof void depth.
- Self-cleaning in many situations.

Note: Siphonic drainage is generally not appropriate for inverted roofs.

For further information see [www.siphonic-roof-drainage.co.uk](http://www.siphonic-roof-drainage.co.uk)

These roof proposal are to be considered on a case by case basis and full design and calculations should be submitted for Warranty approval before construction begins on site.

## Materials - Requirement

### Compatibility of components

The selection of components within the roofing system should be discussed in detail with the membrane manufacturer or appropriate trade association to ensure chemical and mechanical compatibility between components, since the incorrect specification may lead to reduced performance or premature failure of the roofing system. The correct choice of insulation is also important when it is to be adhered to the substrate. In case of doubt, the insulation manufacturer or relevant trade association should be consulted.

### General

Materials for use in flat roofing systems are suitable only if the manufacturer has declared compliance with the relevant harmonised European Assessment Document (ETA, previously a European Assessment Guideline, ETAG) and has affixed the CE Mark to the product. All waterproof membrane products shall also have a certificate of fitness for purpose issued by a member of the European Union of Agrément (UEAtc). This may comprise a British Board of Agrément certificate or an equivalent certificate of another UEAtc member.

### Requirement

The waterproof membrane should be selected with regard to the following minimum criteria:

- Anticipated service life based on independent certification.
- Minimum maintenance.
- Ease of adaptation and repair.

### External fire performance

All roof coverings within close proximity of buildings must achieve the fire designation required by the relevant Building Regulations.

### Statutory requirement

Design for external fire performance must comply with current Building Regulations.

### Certification of system

The manufacturer of the waterproof membrane must demonstrate by reference to independent test certification that the system of waterproofing and insulation (type and thickness) for a particular project meets or exceeds the minimum level of fire performance defined by the Building Regulations.

### Polymeric single ply membranes

The manufacturer should declare compliance with the harmonised European Product Specification for single ply membranes, BS EN 13956, which defines requirements for testing and declaration of characteristic values.

There is no relevant British Standard. Products suitable for roofing should have current certification by one of the following:

- British Board of Agrément.
- Another member of the UEAtc.
- Another notified body.

Such certification should be accompanied by full instructions for installation.

There is no British Standard for the installation of single ply membranes. Installation should be in accordance with the Single Ply Roofing Association's Design Guide to Single Ply Roofing and with the specific instructions of the membrane manufacturer.

The attachment of the single ply membrane should be designed to resist calculated wind load by a declared safety factor of two times (200%). This design will normally be provided by the membrane manufacturer.

Whatever the means of attachment, specific restraint is always required at the roof perimeter, at changes of slope and around details. This ensures that any tension in the membrane in the roof field or upstand is not transferred to the other as a peeling action.

Perimeter restraint is achieved by several methods, depending upon the

manufacturer:

- Individual fasteners, protected by a flashing.
- A linear bar, protected by a flashing.
- Welding the field sheet to a membrane-coated metal trim secured to the deck (with thermal break fasteners where appropriate).

If restraint relies upon adhesive alone, the membrane manufacturer shall provide evidence of satisfactory testing for resistance to wind load using a method defined by the Single Ply Roofing Association.

If the remainder of the roof system is to be bonded, it is essential that the design resistance to wind load is also achieved for the attachment of these components.

Irrespective of the wind uplift considerations or distribution requirements for securing the membrane, the fixing of the insulation boards should always be considered separately, unless specifically sanctioned by the membrane manufacturer. The number and distribution of mechanical fasteners required to fix the insulation boards may vary with the insulation type, geographical location of the building, topographical data and the height of the roof concerned.

The upper termination of the single ply membrane at linear details such as plinths, parapets, abutments and door openings should be secured by one of the following mechanical means:

- Clamping beneath a metal rail, e.g. a parapet capping or roof light frame.
- Welding to a membrane-metal laminate trim (itself mechanically fixed).
- Mechanical fixing using individual fasteners or a mechanically fixed termination bar.

The welding of single ply membranes is a critical process. The following should be considered:

- Supply of certification for each installer indicating successful completion of the manufacturer's product specific training.
- Provision of consistent electrical power supply.
- Production and retention of test weld samples at the start of each day.
- Declared procedures for repair of weak welds or damage.

### Methods of restraint of a single-ply membrane at perimeters

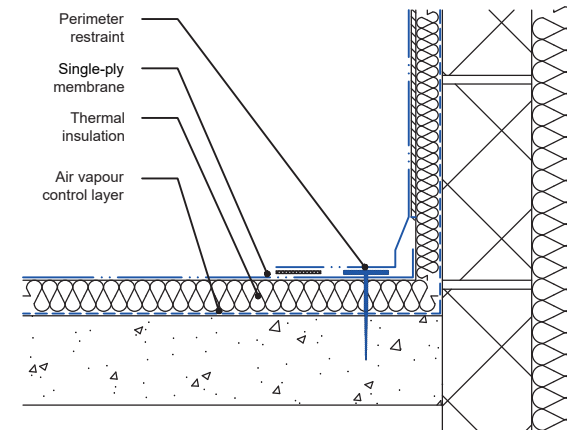

### Warm roof systems with polymeric single ply membranes

Where the insulation is mechanically fixed, the number and arrangement of fasteners required to resist wind load will be prescribed by the manufacturer, applying a safety factor of two to the design load on each fastener. This arrangement may vary across the roof according to wind load, but should be followed in all areas. Thermal break fasteners shall be used wherever feasible.

Where the insulation is adhered, the adhesive should be approved by the insulation manufacturer and should be laid at the coverage rate and pattern designed to achieve calculated wind load with a safety factor of two times (200%). The contractor should allow for temporary loading as required to achieve a suitable adhesion and to achieve the best possible level in the upper surface of the insulation.

### Liquid applied membranes

There is no harmonised European Product Specification for liquid applied membranes for roofing. The European Technical Approval Guideline ETAG 005 Part 1 - General gives overall guidance on assessment of fitness for use, including methods of verification and attestation of conformity. The remaining seven parts, known as the Complementary Parts or the ETA Parts, deal with specific requirements for particular families of products, and are therefore generic types covered primarily by this Guidance Note, shown as follows:

- Part 2: Polymer modified bitumen emulsions and solutions.
- Part 3: Glass reinforced resilient unsaturated polyester resins.
- Part 4: Flexible unsaturated polyesters.
- Part 5: Hot applied polymer modified bitumen.
- Part 6: Polyurethanes.
- Part 7: Bitumen emulsions and solutions.
- Part 8: Water dispersible polymers.

The manufacturer of a product for use in flat roofing should declare compliance with the relevant parts of ETAG 005. In the absence of this declaration, the product should have a current certificate of fitness for purpose issued by one of the following:

- British Board of Agrément.
- Another member of the UEAtc.
- Another notified body.

Such certification should be accompanied by full instructions for installation.

### Installation of Liquid Applied Membranes

There is no British Standard for the installation of liquid-applied membranes. Installation should be in accordance with the Liquid Roofing and Waterproofing Association guidance, as follows:

- Guidance Note No. 2 - Substrates for liquid applied waterproofing.
- Guidance Note No. 4 - Roof, Balcony and Walkway Refurbishment Using Liquid applied Waterproofing Systems.
- Guidance Note No. 5 - Health and Safety Provision for LAWS on Roofs, Balconies and Walkways.
- Guidance Note No. 6 - Safe Use of Liquid applied Waterproofing Systems.
- A consistent film thickness is essential for reliable and durable liquid-applied membranes.

The following should be considered:

- Supply of a card for each installer indicating successful completion of the manufacturer's product-specific training.
- The coverage rate in kg/m<sup>2</sup> must be declared before work starts.
- During installation assessment of wet film thickness by one of the following methods as appropriate:
  - Gauge pin.
  - 'Comb' type measurer.
  - Visual inspection.

### EPDM roof coverings

EPDM roof coverings are not acceptable where used on a:

- Balcony/terrace decks
- Blue roof
- Green roof
- Podium deck.

## Mastic asphalt

There is no harmonised European Product Specification for mastic asphalt for roofing. Products used for flat roofing should comply with BS 6925: 1988 Specification for mastic asphalt for buildings and civil engineering (limestone aggregate).

Proprietary grades of polymer modified mastic asphalt are produced for roofing and paving applications. There is no British Standard or European Standard for these products.

Products suitable for roofing should have current certification by one of the following:

- British Board of Agrément.
- Another member of the UEAtc.
- Another notified body.

The separating membrane should be one of the following, and should be laid directly under the mastic asphalt:

- Sheathing felt, comprising a base of flax or jute, or other suitable fibres, impregnated with bitumen.
- Glass fibre tissue.

Bitumen-coated plain expanded metal lathing should be in accordance with BS EN 13658-2.

Stone chippings (bedded) for use as a protective topping should be washed, crushed rock, normally 10mm-14mm nominal size aggregate, bedded in a proprietary gritting solution over the mastic asphalt membrane.

## Warm roof systems with mastic asphalt waterproofing

Generally, mastic asphalt on sheathing felt provides sufficient dead load to resist wind load, but this should be demonstrated by calculations in all situations.

## Installation of mastic asphalt

The number of coats should be appropriate to the waterproofing requirements and traffic conditions of the roof. When laid to falls of 1:80 or more, mastic asphalt roofing is laid in two coats to a thickness of 20mm, on a separating membrane of sheathing felt, all in accordance with BS 8218.

On sloping and vertical surfaces over 10° pitch, the mastic asphalt should be laid in three coats to a thickness of 20mm without a separating membrane.

On sloping and vertical surfaces of timber or lightweight concrete, the mastic asphalt should be laid in three coats to a thickness of 20mm on expanded metal lathing over a separating membrane of sheathing felt.

## Reinforced bitumen membranes

The manufacturer should declare compliance with the harmonised European Product Specification for reinforced bitumen membranes, BS EN 13707, which defines requirements for testing and declaration of characteristic values. There is no relevant British Standard.

Products suitable for roofing should have current certification by one of the following:

- British Board of Agrément.
- Another member of the UEAtc.
- Another notified body.

In addition, specifications for systems of multi-layer reinforced bitumen membranes for flat roofing should comply with BS 8747.

## Minimum recommended specification for reinforced bitumen membranes

Roof system type	Deck type	Insulation type <sup>(1)</sup>	Venting layer <sup>(2)</sup>	Underlayer <sup>(3)</sup>	Cap sheet <sup>(4)</sup>
Warm deck	Profiled metal	Thermoplastic foam	3G	S2P3 <sup>(5)</sup>	S4P4 <sup>(5)</sup>
		Mineral fibre	-	S2P3	S4P5
	Concrete	Thermoplastic foam	-	S2P3	S4P4
		Mineral fibre	-	S2P3	S4P4
	Timber panel	Thermoplastic foam	3G	S2P3	S4P5
		Mineral fibre	-	S2P3	S4P4
Inverted warm deck	Profiled metal	Extruded Polystyrene (XPS)	3G	S2P3	S4P5
	Concrete		-	S2P3	S4P5
	Timber panel	Deck type not suitable for inverted roofs			

Notes:  
 (1) Insulation type: Thermoplastic foam: PIR, EPS, PF. Mineral fibre: MW  
 (2) Venting layer: BS 8747 3G or proprietary equivalent with suitable certification  
 (3) Under layer: as defined in BS 8747. SBS-modified products are recommended  
 (4) Cap sheet: as defined in BS 8747. SBS-modified products are recommended  
 (5) S and P are classifications 1-5 of Strength (tensile strength and elongation) and resistance to puncture (static and dynamic); the higher the rating, the higher the performance

Bitumen membranes should be protected from solar radiation. This should be by integral protection provided in the product in the form of:

- Mineral granules.
- Metal foil.

The use of solar reflective paint is not permitted. The use of stone chippings is not recommended unless required to achieve enhanced external fire performance. If used, chipping's should be washed, crushed rock, normally 10mm-14mm nominal size aggregate, bedded in a proprietary gritting solution.

## Warm roof systems with reinforced bitumen membrane waterproofing

The limiting wind load for the different methods of attachment of insulation is prescribed by BS 8217 as follows:

- Partial bitumen bond: up to 2.4kN/m<sup>2</sup>.
- Full bitumen bond: up to 3.6kN/m<sup>2</sup>.

Where the method of attachment is outside the scope of BS 8217, the manufacturer should demonstrate that the method provides sufficient resistance to wind load.

## Reinforced bitumen membranes installation

Installation should be in accordance with BS 8217. In case of doubt, or where the waterproof membrane is beyond the scope of the Standard, the advice of the Flat Roofing Alliance (National Federation of Roofing Contractors) should prevail.

The safe use of gas torches, and the positioning, monitoring and transferring hot bitumen to the work face, should be adopted, all in accordance with the Health and Safety Executive/Flat Roofing Alliance Code of Practice for Safe Handling of Bitumen.

The practice of applying reinforced bitumen membranes by torching onto thermoplastic foam insulation is not permitted, unless the boards are manufactured with a covering of reinforced bitumen membrane

## Site-applied hot-melt coverings

There is no harmonised European Product Specification for site-applied hot-melt waterproofing systems.

Products suitable for roofing should have current certification by one of the following:

- British Board of Agrément
- Another member of the UEAtc
- Another notified body

As these systems comprise a multi-layer application (usually a base coat, reinforcement and top coat), a detailed specification for the system should be available prior to commencement of the works to enable its suitability for the project to be confirmed.

## Site-applied hot melt coverings

There is no British Standard for the application of proprietary hot melt waterproof membrane systems. Reference should be made to independent certification and the manufacturer's detailed instructions.

## Fixing of guarding/balustrades

Fixings for balustrades must be carefully designed to ensure appropriate fixings are robust and any penetration through waterproof roof coverings is sealed correctly in accordance with the waterproof covering manufacturer's recommendations.

## Protection of waterproof system during construction

At the earliest possible stage, the anticipated loading of the balcony, terrace or podium area by plant and access during service should be assessed in terms of:

- Load, e.g. foot traffic, equipment.
- Frequency.
- Risk of impact.

If such usage is intense or long-lasting during the construction phase, consideration should be given to temporary works only, with completion occurring after all non-roofing usage has ceased as follows:

- Warm deck roof system: installation of temporary vapour control layer (VCL) to be overlaid when remainder of system is installed.
- Inverted warm deck roof system: overlay of completed waterproof membrane with geotextile and continuous temporary decking, such as plywood, oriented strand board or compatible recycled thermoplastic board.

Responsibility for temporary protection and a method statement for its use should be agreed prior to the commencement of works. Suitable materials should be selected in consultation with membrane manufacturers as appropriate, for example:

- Linked recycled thermoplastic sheets.
- Rolled recycled thermoplastic or elastomeric sheets.

Particular consideration should be given to locations of concentrated access, such as step-out areas onto the roof or where wheeled equipment may be used.

## Provision for access

### Statutory requirement

Balconies should have suitable access and drainage meeting the requirements of the current Building Regulations.

### Ancillary components

### Lightning protection

The following should be confirmed by reference to the manufacturer's information or independent certification, as appropriate:

- Design in compliance with BS EN 62305.
- Method of attachment to the waterproof membrane, including arrangements for self-ballasting of conductors and finials (centres, compressive loads).
- Recommended detailing at penetration of roof system.

Detailing

General principles

At an early stage in the design process, an audit of balcony/terrace geometry should be carried out to establish what types of details will be required and whether they are to be weather proof (incorporating an upstand/cover flashing arrangement) or waterproof (providing continuous waterproofing across the detail).

The following key principles should be followed in the design of all details:

- Upstands to extend 150mm above finished roof level, except at door access to balconies and terraces.
- Downstands (of separate metal or other flashings) should lap the upstand by a minimum of 75mm.
- Where the balcony or terrace forms part of the entire roof of an occupied building, a continuous barrier to air leakage should be maintained.
- Reliance on sealant as the sole means of protection is not acceptable.

The total roof zone depth should be assessed at critical points, such as the top of drainage slopes, to ensure there is enough free upstand available to create the minimum required 150mm of waterproofing protection above finished roof level. It is important that this minimum 150mm upstand is maintained at all points around the waterproofed area, except at door access to balconies. Balconies are a frequent and acceptable exception due to the need for level or unobstructed access, provided the recommendations in this section are followed.

Designers should carefully consider the risks of any departure from this criterion. In the event that variation of this guidance is unavoidable a written justification for assessment by the Warranty Surveyor should be provided by the balcony designer.

Special design features are essential, depending upon the generic type of waterproof membrane, including:

- Minimum clearances to enable the waterproof membrane to be installed.
- Termination of the waterproof membrane at interfaces to other elements.
- Penetrations.
- Supports.

Upstand at door access - Warm deck roof - Level threshold

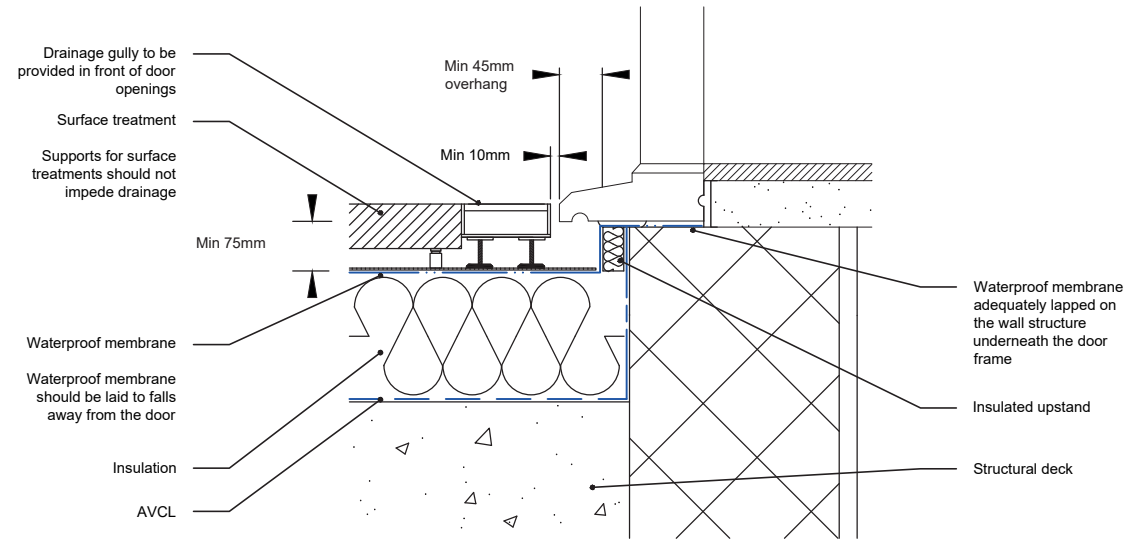

Upstand at door access - Inverted warm deck roof - Level threshold

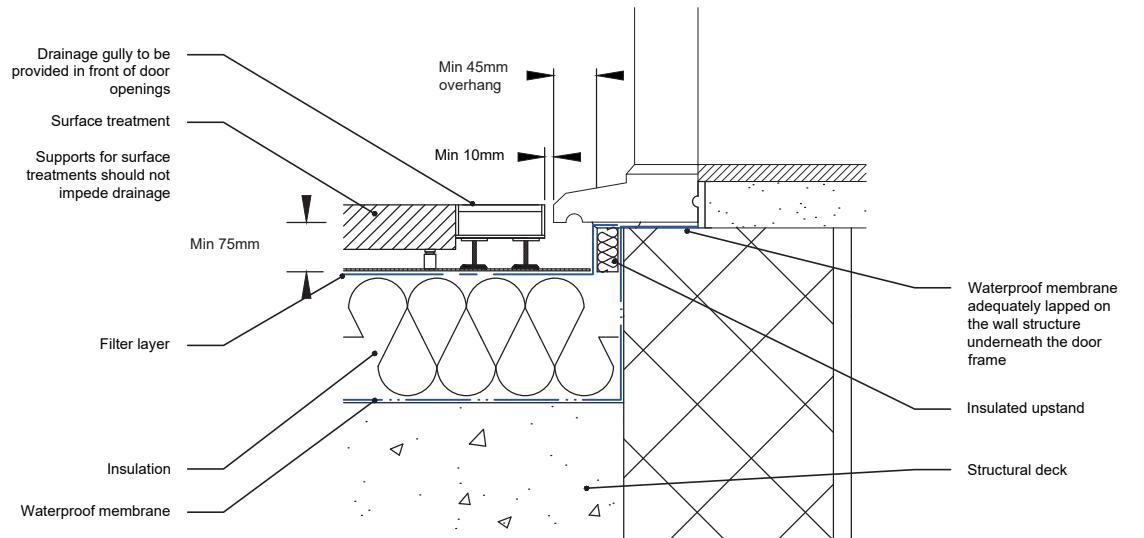

Penetration through roof system

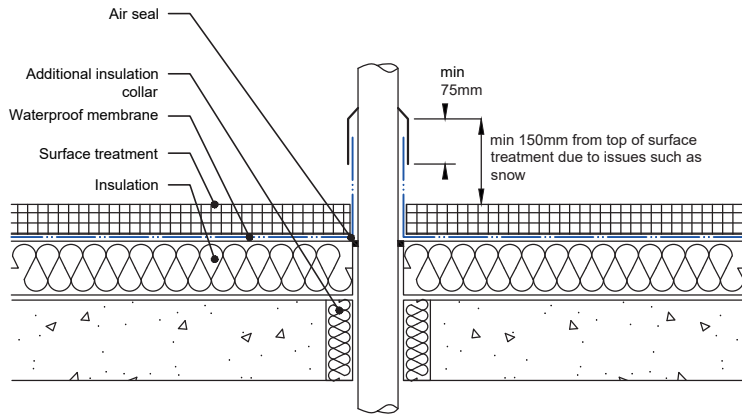

Notes:

- A fillet is required at the base of the upstand for certain types of waterproof membrane.
- An effective seal is required between the air vapour control layer and pipe. Clearly it is difficult to dress a sheet material around a pipe. The method for doing so should be stated in the contract drawings and/or specification.

Special design features

Special design features are essential, depending upon the generic type of waterproof membrane, including:

- Minimum clearances to enable the waterproof membrane to be installed.
- Termination of the waterproof membrane at interfaces to other elements.
- Penetrations.
- Supports.

Mechanical and electrical services

Detailed design should take account of the installation of such equipment by other (usually following) trades, as follows:

- Service entry/exit points should be suitably weathered to enable connection without loss of integrity of the waterproof membrane and without the involvement of the roofing specialist.
- The upstand of the waterproof membrane at risers should be arranged to enable a separate downstand or weathering flashing to be formed in ductwork.
- Cladding to insulation placed around ductwork should not be sealed to the waterproof membrane.
- Sufficient clearance should be provided to horizontal ductwork to ensure it does not rest upon the waterproof membrane or roof finish.

Support for renewable energy capture equipment

Renewable energy capture equipment includes photovoltaic panels and multi-panel arrays, solar thermal panels and multi-panel arrays and wind turbines. All such equipment should be secured to a frame and/or posts that transfer their load directly to the structure. The roof system and waterproof membrane should be designed to enable equipment to be de-mounted without loss of the roof's waterproofing integrity and without the involvement of the roofing specialist. Support systems based on 'top-fixed' plate and post components should be accompanied by documentation to demonstrate their compatibility with the waterproof membrane.

Principles: Flat roof interface to pitched roof

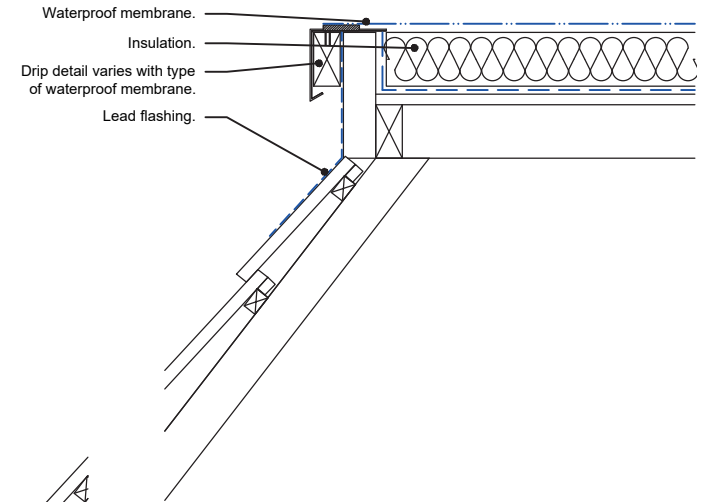

Edge protection

If guarding to the perimeter of flat roofs should be designed to provide the simplest means of achieving waterproofing integrity, given that installation of balustrade or stanchions may occur after the installation of the roof system.

If the design requires a collar of waterproof membrane at the stanchion, the stanchion should be of circular section at this point and should incorporate a weathering apron.

Fall-arrest and edge protection equipment

The following should be confirmed by reference to the manufacturer's information or independent certification, as appropriate:

- Compliance with BS EN 795.
- Method of attachment.
- Compatibility with the waterproof membrane.
- Means of forming a water tight seal to the waterproof membrane.

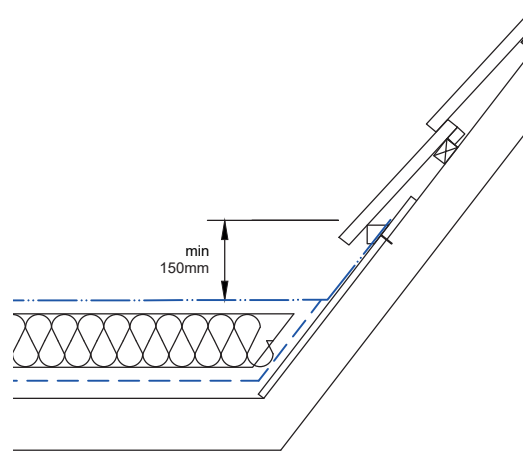



Upstand to decking and paving finishes e.g. where access is required

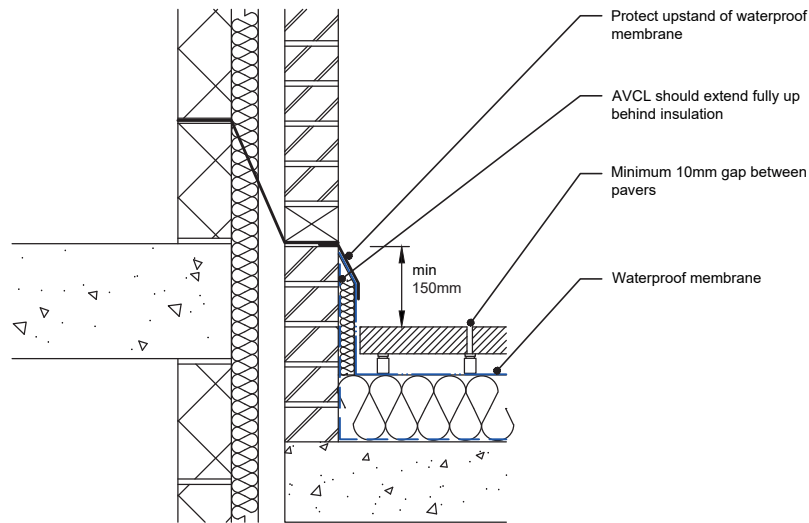

Timber frame construction where a lower level construction meets a brick outer leaf wall to roof abutment timber frame

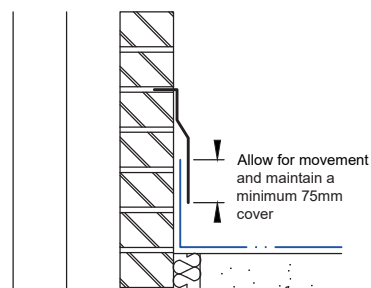

Where a timber frame structure abuts a masonry structure allowance should be made to accommodate movement in the timber frame and ensure the appropriate cover is maintained

For detailing with parapet wall construction, see the 'External Wall' section

Edge protection/guarding

The guarding to the perimeter of balconies/terraces should be designed to provide the simplest means of achieving waterproofing integrity, given that installation of balustrade or glazing stanchions may occur after the installation of the roof system.

Acceptable examples include the following, in order of preference:

Full-height parapet walls:

- Stanchions or rails secured to low parapet walls above the level of the waterproof membrane (incorporated in copings or secured to elevation).
- Stanchions secured, clamped and sealed to stainless steel bolts set in raised plinths, which were constructed prior to application of the waterproof membrane (suitable for warm deck and inverted warm deck roof systems).
- Stanchions secured, clamped and sealed to stainless steel bolts set at deck level, which were installed prior to application of the waterproof membrane (suitable for warm deck roof systems only).

If the design requires a collar of waterproof membrane at the stanchion, the stanchion should be of circular section at this point and should incorporate a weathering apron.

Pedestrian access finishes

- The design should include protection to suit the anticipated conditions as appropriate.
- Pedestrian access finish and there supports should not impeded the ability for the balcony to drain to all outlets.
- Supports or pedestals to pedestrian finishes should not be mechanically fixed through the waterproof membrane.
- All pedestrian access finished should comply with the relevant Regional Building regulations in regards to combustibility requirements in regards to a relevant boundary.

Pedestrian finishes for balconies/terraces

Finish	Roof system type		Waterproof membrane type			
	Warm	Inverted	Single Ply membrane	Bitumen membrane	Mastic asphalt	Liquid applied
Porous concrete tiles adhered to waterproof membrane <sup>(1)</sup>	Y	N	N	Y	Y <sup>(2)</sup>	Y
Fired tiles bedded in screed and grouted <sup>(1)</sup>	Y	N	Y	Y	Y <sup>(2)</sup>	Y
Precast concrete paving slabs on adjustable supports <sup>(3,4)</sup>	Y	Y	Y	Y	Y	Y

- Notes:
- (1) Product should be certified for use with waterproof membrane.
  - (2) Consideration should be given to the effects of solar gain on the stability of mastic asphalt under point loading in this situation.
  - (3) Paving support pad bearing area should be suitable for the compressive strength of the insulation under design loadings.
  - (4) Bearers should not impede drainage, and should be sized to suit the compressive strength of the insulation under design loadings.

Non-access areas: stone ballast

Stone ballast for inverted warm deck roofs and ballasted warm deck roofs should be clean, rounded aggregate graded 20mm-40mm and as free from fines as practicable. Ballast should be applied over a protection layer on warm ballasted systems and over a filter layer or WCM on inverted warm roofs.

Access areas: concrete paving slabs

Concrete paving slabs for use as walkways or as paving on terrace decks should conform to BS EN 1340, and be laid in accordance with the manufacturer's instructions.

It is recommended that concrete paving is laid on support pads as this allows adjustment, reducing risk of trip hazard. Recommendations are as follows:

- The height of support pads should not exceed the maximum recommended by the manufacturer.
- Paving should not be cut.
- Paving should be firmly butted up against support pad separating pegs.
- Support pad separating pegs should provide clear space for rapid disposal of rain water between paving slabs.
- Provision for movement at perimeters should comprise either a 75mm margin of washed stone or a compressible rubberised fill. In either case drainage should not be obstructed and a suitable restraint trim should be used to ensure stone does not fall beneath the paving adjacent.

Access areas: flexible walkway tiles

Evidence of the compatibility of the tile with the waterproof membrane is required.

### Testing

#### Final inspection

At practical completion of the balcony/terrace, all areas should be clear of stored material, other site operations and all protection. A thorough, recorded, visual inspection of all areas, including details, should be carried out with representation from the General Contractor and Roofing Contractor in attendance.

#### Parameters for testing

Upon completion testing of the flat roof covering will be required to be carried out as per the following criteria.

#### Testing of flat roofs and balconies (All types of materials)

Testing is required in the following situations:

1. On large developments: Apartments etc. over 3 stories in height (including the ground storey), where the total combined roof/balcony areas exceeds 50m<sup>2</sup>. In this case, a minimum of 20% of the roof areas must be tested.
2. On Low rise housing: Detached/semi-detached/terraced housing 3 stories or less in height (including the ground storey) when:
  - The roof/balcony areas exceed 50m<sup>2</sup>.
  - Where the project consists of 10 or more properties: one test per ten houses (with a minimum of two tests per site) are required.

In addition to above, in all cases: Testing may be required in the following situations where the complexity of a roof and its ancillary components presents a higher risk. It will be necessary to identify this at the initial site assessment carried out between the Developer and the Warranty Surveyor:

#### Design:

1. If the roof includes features beyond a typical wall abutment e.g. (but not limited to); variations of upstand constructions/penetrations/fixings/external permanent machinery/balustrading fittings etc.
2. If the waterproof membrane is to be covered over (by pedestrian finishes or solar panels). Note: Inverted roofs of straightforward design and with continuous hot-applied waterproof membrane could be exempted.

#### Construction:

3. If there are to be/have been, follow on trades on the roof after completion of the roof covering.
4. If secondary items such as fall protection devices, PV supports, balustrades etc. are to be attached.

#### Procurement of testing services

If testing to demonstrate waterproofing integrity is required it should be undertaken by a suitably qualified and experienced third-party who is independent of the roofing contractor.

The testing service provider should provide evidence of the following:

- Efficacy of the method proposed in the circumstances of the project.
- Experience and training of operator.
- Membership of an appropriate trade association that sets a Code of Conduct for the service

### Methods of test

#### Low voltage earth leakage

Low voltage earth leakage is a safe and effective method for the testing of waterproofing integrity in roofs where the waterproof membrane is an electrical insulator and the deck provides an electrical earth. It is not suitable for testing flat roofs where the waterproof membrane has been overlaid with insulation and ballast (inverted roofs) or ballast only (ballasted warm roofs); therefore, testing should be carried out prior to completion of the roofing system.

#### High voltage electrical discharge

The high voltage electrical discharge method is best suited to the testing of continuous thin films, such as liquid-applied coatings. Its use is not recommended with polymeric single ply, reinforced bitumen membranes and mastic asphalt.

#### Vacuum

Vacuum testing of seams of membranes manufactured off-site is an effective means of quality assessment, but is not recommended as a method of demonstrating the integrity of flat roofs.

#### Flood testing

Flood testing is not recommended as a method of demonstrating the integrity of flat roofs. It may be used to test balconies.

### Approved Installers

Where a roof falls into the criteria below, an approved contractor who is recognised by the manufacturer as competent to install the manufacturer's roof membrane system will need to be used. Evidence of the manufacturer's approval of the contractor to install their products should be provided to the Warranty Surveyor.

A flat roof membrane manufacturer's approved installer must be used for all flat roof coverings in the following situation:

- On large developments over 3 stories in height (including ground storey) where the total combined roof/balcony area exceeds 50m<sup>2</sup>.
- Low-rise housing less than 3 stories in height where the roof/balcony area exceeds 50m<sup>2</sup>.
- Where the roof includes features beyond a typical wall abutment e.g. (but not limited to) variations of upstand constructions/penetrations/fixings /external permanent machinery/balustrade fittings etc.
- Where the waterproof membrane is to be covered over by pedestrian finishes, balustrades/fall protection devices or solar panels.
- Where EDPM roof coverings are proposed.

### Provision of information

#### Operation and maintenance manual

The following information is required.

#### Specification, as-built:

- Waterproof membrane: generic type, product(s) and (as appropriate) thickness.
- Thermal insulation: generic type, product(s) and thickness.
- Acoustic insulation: generic type, product and (as appropriate) thickness.
- Vapour control layer: generic type, product (as appropriate) and thickness (as appropriate).
- Rain water outlets: type, product and capacity.
- Procedure for maintenance of waterproof membrane, including (where appropriate) recommended frequency and method of application of solar reflective finish.
- Procedure for repair of waterproof membrane.

T 0800 183 1755 E [enquiries@labcwarranty.co.uk](mailto:enquiries@labcwarranty.co.uk)

[www.labcwarranty.co.uk](http://www.labcwarranty.co.uk)

MD Insurance Services Ltd. is the scheme administrator for LABC Warranty and is authorised and regulated by the Financial Conduct Authority. Registered in England No: 3642459. **TS-011A-10.00-110621**

