



TECHNICAL MANUAL

VERSION 10

D.

Appendix D

Contents

Functional Requirements

- D.1 Conversions and Refurbishments - Existing Elements
- D.2 Conversions and Refurbishments - New Elements Connecting to Existing Structures
- D.3 Conversions and Refurbishments - Buildings with Historic Significance

ADDITIONAL FUNCTIONAL REQUIREMENTS

D.1 Existing elements

Workmanship

1. Any new work must meet the tolerance requirements detailed in the Technical Manual. Tolerances will not apply to existing finishes e.g. walls and floors that have not been upgraded or altered, or where the supporting elements will not allow for the tolerances to be met.

Materials

1. The structure, regardless of whether it is a new or existing element, shall, unless specifically agreed otherwise with the Warranty provider, have a residual service life of not less than 60 years. A Structural Engineer will need to explicitly confirm this in a written report. Individual components and assemblies, not integral to the structure, may have a lesser durability, but not in any circumstances less than 15 years.
2. Existing elements that are to be retained must provide a 'waterproof envelope' to the building and be structurally adequate.

Design

1. The design and specifications should give clear indication of the design intent and demonstrate a satisfactory level of performance with regards the renovation of components and the interaction of new elements.
2. Specialist reports are required to confirm that existing elements will have an adequate level of:
 - a. Structural stability, as defined in the materials section above and,
 - b. Confirm the adequacy of the existing 'waterproof envelope' as defined in the materials section above

D.2 New elements connecting to existing structures

Workmanship

No additional requirements.

Materials

No additional requirements.

Design

1. The design and specifications should give clear indication of the design intent and demonstrate a satisfactory level of performance with regards the renovation of components and the interaction of new elements.
2. Specialist reports are required to confirm that existing elements will have an adequate level of structural stability, as defined in the materials section above, the reports must confirm the adequacy of the existing 'waterproof envelope'.
3. There should be a Party Wall Agreement in accordance with the Party Wall etc. Act (please note that this requirement will be relevant where the applicant is not the owner of the adjoining property).
4. The separating wall between the new and existing building must meet the relevant requirements of the regional Building Regulations.
5. The existing foundations and wall structure must be suitable to support any proposed increased loading resulting from the construction of the new building.
6. The junction of the new walls to the existing walls must ensure that dampness cannot track back into the new or existing building.
7. An effective Damp Proof Course should be present in the existing wall, linked to the new Damp Proof Course and Damp Proof Membrane of the new building.
8. At the junction of the existing and new structures, detailing should allow for differential movement without cracking. Any settlement should be limited to 2mm-3mm, which would not normally adversely affect the roof covering.

D.3 Buildings with Historic significance

Workmanship

1. Any new work must meet the tolerances requirements set out in this Manual. Tolerances will not apply to existing finishes that have not been upgraded or altered, or where the supporting elements will not allow for the tolerances to be met.

Materials

1. The structure, regardless of whether it is a new or existing element, shall, unless specifically agreed otherwise with the Warranty provider, have a residual service life of not less than 60 years. Individual components and assemblies, not integral to the structure, may have a lesser durability, but not in any circumstances under 15 years.
2. Existing elements that are to be retained must provide a 'waterproof envelope' to the building and be structurally adequate.

Design

1. The design and specifications should give clear indication of the design intent and demonstrate a satisfactory level of performance with regards the renovation of components and the interaction of new elements.
2. Specialist reports are required to confirm that existing elements will have an adequate level of:
 - a. Structural stability, as defined in the materials section above and,
 - b. Confirm the adequacy of the existing 'waterproof envelope' as defined in the materials section above.

D.

Appendix D

D.1

Conversions and Refurbishments - Existing Elements

The guidance that follows is for buildings that do not have any Historic or Conservation Planning restrictions. It is expected that the building can be appropriately upgraded in accordance with current Building Regulations with respect to structure, fire, resistance to moisture, sound, ventilation, drainage, heat producing appliance, conservation of fuel and power, access and security.

The following building types will not be considered suitable for warranty cover:

- Grade 1 listed buildings.
- Scheduled and ancient monuments.
- Cob construction.
- Through wall oak/timber frame.
- Wattle and daub.
- Former agricultural buildings of any nature, with the exception of farm houses.
- Barns.

Conversions and refurbishments are projects that involve work to existing buildings or parts of existing buildings. This could include the conversion of industrial or commercial buildings into housing, the conversion of an existing residential building into flats, an additional storey to an existing building, the refurbishment of an existing residential building, or a façade retention project.

The process

The Warranty includes cover for the retained structural elements and water proof envelope of any existing building for the duration of the policy. Any conversion or refurbishment will be the subject of a Refurbishment Assessment by our Warranty Technical Surveyors and this should occur before you start planning or building.

The Warranty Surveyor will always undertake an initial assessment of the existing fabric to ascertain in general terms if the proposal is capable of representing a standard risk to the Underwriter. If deemed acceptable, the development is then subject to a technical audit process during construction, and the following guidance is intended to assist all parties in ensuring the relevant requirements are met, as well as providing an element of consistency in approach.

Depending on the condition of the original building; an expert survey may be required for the different elements of the building as described in the following guidance. If the survey concludes that any of these elements are unable to achieve a residual service life of 60 years for structural elements and 15 years for non-structural elements, they should be systematically replaced or repaired.

Existing buildings and structures can present particular problems both initially and on an ongoing basis. Therefore, it is essential that thorough and comprehensive survey work is undertaken prior to new works commencing to understand both the current condition of any structure and the impact any proposed works may have. Although initially this may be considered an unnecessary early expense, the savings in reconstruction costs can greatly outweigh the cost of the preparatory work.

Elements of the retained structure and proposed works should not be considered in isolation, as a solution for one problem may cause issues elsewhere. Past performance is no guarantee of ongoing adequate performance because different expectations and changing living conditions can all impact on both the actual and perceived performance of a converted/refurbished structure.

It is not possible to cover every building type within this guidance, therefore, the guidance is general, and certainly will not apply in every scenario. It is strongly recommended that early discussions are held to determine exact requirements and to enable a full review of the proposed strategy and development.

Where new work is proposed, it should follow the guidance for those elements in the various Building part sections earlier in this Technical Manual. Where new work is applied to, or meets, existing elements, consideration on how these areas will interact must be made; for example, new cavity masonry that abuts an existing solid wall construction. If works have progressed to a stage beyond where it is not possible to survey the structure or that new works have been carried without inspection, it is highly likely that the scheme cannot be considered a standard risk and the offer of warranty may be withdrawn.

Please note that the requirements of the technical audit are quite different from those undertaken for the purposes of compliance with Building Control and Planning legislation. If any such bodies have imposed restrictions on the areas above, we suggest that you contact the Technical Services Department before undertaking any works.

General guidance for retained elements

Foundations and load-bearing structures (including floors, walls and roofs)

All existing structures will be subject to a structural appraisal by a Chartered Structural Engineer. The Structural Engineer will be asked to provide a report, based upon a fully intrusive survey, to confirm that the structure and its individual components are structurally sound and has, in their professional opinion, a residual service life of 60 years.

Any areas of cracking or suspected movement are to be assessed and remedial measures provided by the Structural engineer that will confirm a 60 years residual service life will be achieved, once the remedial works have been satisfactorily completed. Furthermore, any additional loads must be catered for and consideration of the impact of any landscaping and drainage works is required.

Damp Proof Course (DPC) and Damp Proof Membranes (DPM)

All walls, floors level should include a functioning DPC. If it cannot be confirmed if there is a functioning DPC, or if there are signs of dampness at low level, a damp survey will be required to be undertaken by a member of the Property Care Association. Where a remedial DPC is required, ground levels and ventilation should be checked before any remedial DPC treatments are considered. However, where remedial DPC treatments are required, these must be appropriate to the type of construction, independently tested/approved and provided with a 10 year insurance-backed guarantee. Remedial DPC treatments must be installed by a member of the Property Care Association and the guarantees must cover workmanship and materials. A copy of the guarantees should be provided for our records upon completion of any remedial treatment carried out

All existing ground bearing slabs should have a functioning DPM. The construction of the floor shall be assessed by a member of the Property Care Association and any remedial treatment required must be appropriate to the type of construction, independently tested/approved and provided with a 10 year insurance-backed guarantee. Remedial DPM treatments must be installed by a member of the Property Care Association and the guarantee must cover workmanship and materials. A copy of the guarantee should be provided for our records upon completion of any remedial treatment carried out.

Timber treatment against insect and fungal attack

If existing timbers are to be retained, a timber condition report is required to be produced by a member of the Property Care Association. All retained timbers will need to be assessed, logged and the remedial treatment noted. Any remedial treatment must be provided with a 10 year insurance-backed guarantee and undertaken by a member of the Property Care Association, where guarantees must cover workmanship and materials. A copy of the guarantees must be provided for our records upon completion of any remedial treatment carried out.

Roof coverings

Coverings and support systems should be replaced unless a specialist report compiled by an independent Chartered Building Surveyor or similar approved consultant concludes that the roof covering system has a residual service life of 15 years. This should include the covering, battens, felt, flat roof decking, fascia's, soffits, flashings, nails and clips, etc.

Note: we will not accept any existing roof covering that does not have a breather membrane/sarking felt.

Weather resistance of walls, including claddings, render, re-pointing, etc.

The existing walls of the building shall provide a weathertight barrier. The existing walls or cladding system will need to be assessed, to confirm that they are in good condition, suitable for the building's exposure rating as provided by BS 5628 and shall provide a weathertight envelope for the next 15 years.

External doors and windows

In general, all windows considered to be over the age of 15 years old will be required to be replaced. Typical exceptions may include existing windows that are subject to planning and conservation restrictions. If windows are to be retained, a condition survey and report will be required by an independent, qualified Surveyor or specialist to confirm a residual service life of 15 years. Consideration must be given to improving the thermal characteristics.

Where repairs to windows are required we will ask you to prepare a sample repair on site so our Risk management Surveyor can bench mark the required standard and this can be rolled out across the site refurbishment. Note: painting windows does not make them newly constructed.

Sound testing

Party walls and party floors should be sound tested in accordance with the Building Regulations to determine compliance. Access maybe required into adjacent buildings in order that sound testing is completed. Test and declare is not permitted unless the building is classed as a 'historic building' as defined by the Building Regulations and dispensations are placed on the requirements of the regulations by the Local Authority.

External and internal services

Any services to be retained should be suitably tested and reported by a specialist. The specialist should also confirm fire compartmentation requirements as necessary.

Drainage

Drainage systems should be replaced unless it can be demonstrated that the existing drainage system is fit for purpose, have suitable falls and the required rodding facilities.

Where private drains are retained, a CCTV survey should be undertaken to ensure the integrity and design of any retained system. Where the lengths of existing retained drainage do not have rodding access in accordance with current requirements, additional access points should be provided. Inspection chambers and manholes located within habitable parts of the building will not normally be acceptable. Existing septic tanks and cesspools should be replaced with a new sewerage treatment system.

Where some of the elements are new and replaced as part of the conversion/refurbishment, no report is necessary.

Foundations

An appraisal of the existing building and its foundations should be carried out by a Structural Engineer. A copy of the report should be provided and retained for our records.

This appraisal should address:

- Settlement.
- Heave.
- Foundation depth and type.
- Soil type.
- Basement walls and floors.
- Trees adjacent to buildings.
- Undermining due to new floor structures or building services.

When carrying out the appraisal, the person responsible should take into account any proposed increased loading on the structure and foundations, alterations to existing load paths and any alterations to the existing stability of the building.

Where the existing foundations are inadequate and the building has moved/cracked, and/or the proposals are to increase the load on the foundations, a Structural Engineer should design a suitable solution, which should certify a residual service life of 60 years once the remedial works have been satisfactorily completed. This must be discussed with the Warranty Surveyor prior to implementation. Proposals for underpinning should be prepared by an expert and be in accordance with BS 8004.

Where trees are within close proximity of the existing structure, the potential risk of movement must be fully assessed. A detailed analysis supported by comprehensive structural designs and calculations should be provided supported by soil samples to determine the plasticity of the ground and the extent of the root intrusion beneath or around the building.

Partial Underpinning

Partial underpinning will only be considered where it is fully supported by full structural details and calculations and that the superstructure is assessed for differential movement. Movement joints should be provided between existing and underpinned/new foundations.

Typical traditional underpinning detail

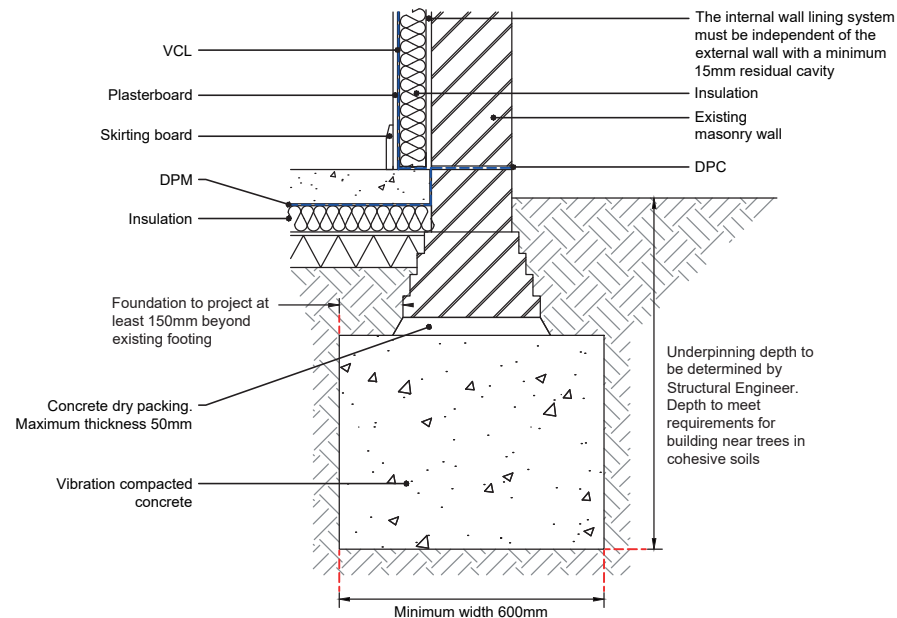

'Hit and miss' underpinning sequence

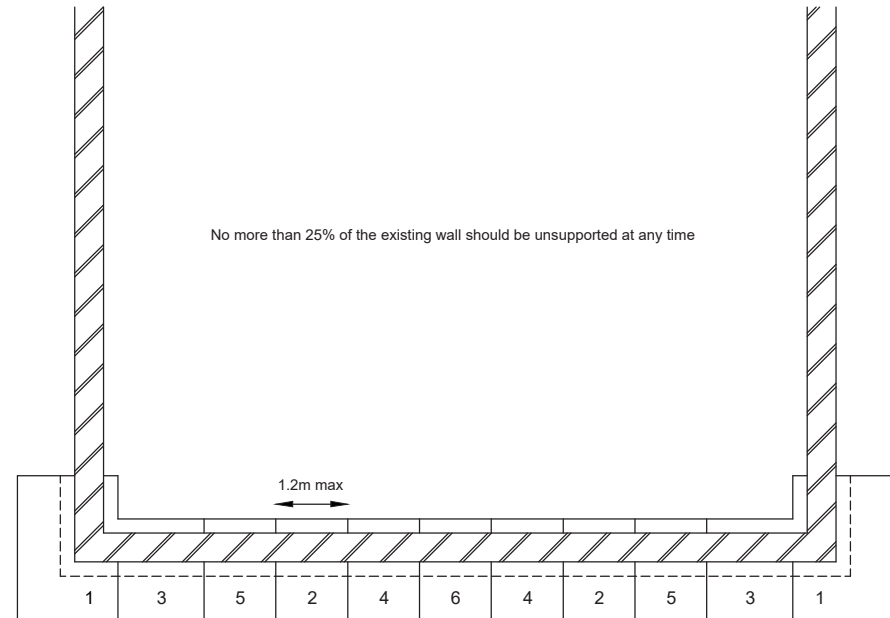

Basement Structural Waterproofing

Our standards to basement conversion are no different to our New Homes approach, where it is intended that there will be any usable space below ground level (fully or partially), then the design should be such that adequate resistance to the passage of water/moisture to the inside is achieved, following the guidance in BS 8102. Please refer to the 'Basement' section for further information for basement provision. You must appoint a CSSW specialist to design, inspect and certify the waterproofing.

Where a basement area on a converted or refurbished site is not habitable or used for plant storage, any damp/water ingress occurring is specifically excluded from the Policy.

Excluded is: water entry, dampness or condensation to the enclosing walls, floors and ceilings of any underground: car-parking and any associated underground refuse stores, cycle stores, plant rooms (that do not house items of plant that directly service the Home and for which the failure of such plant would prevent the normal use of the Home), lifts / escalators, associated access stairs and lobbies; where the structural integrity of the Home is not affected.

Typical chemically injected DPC

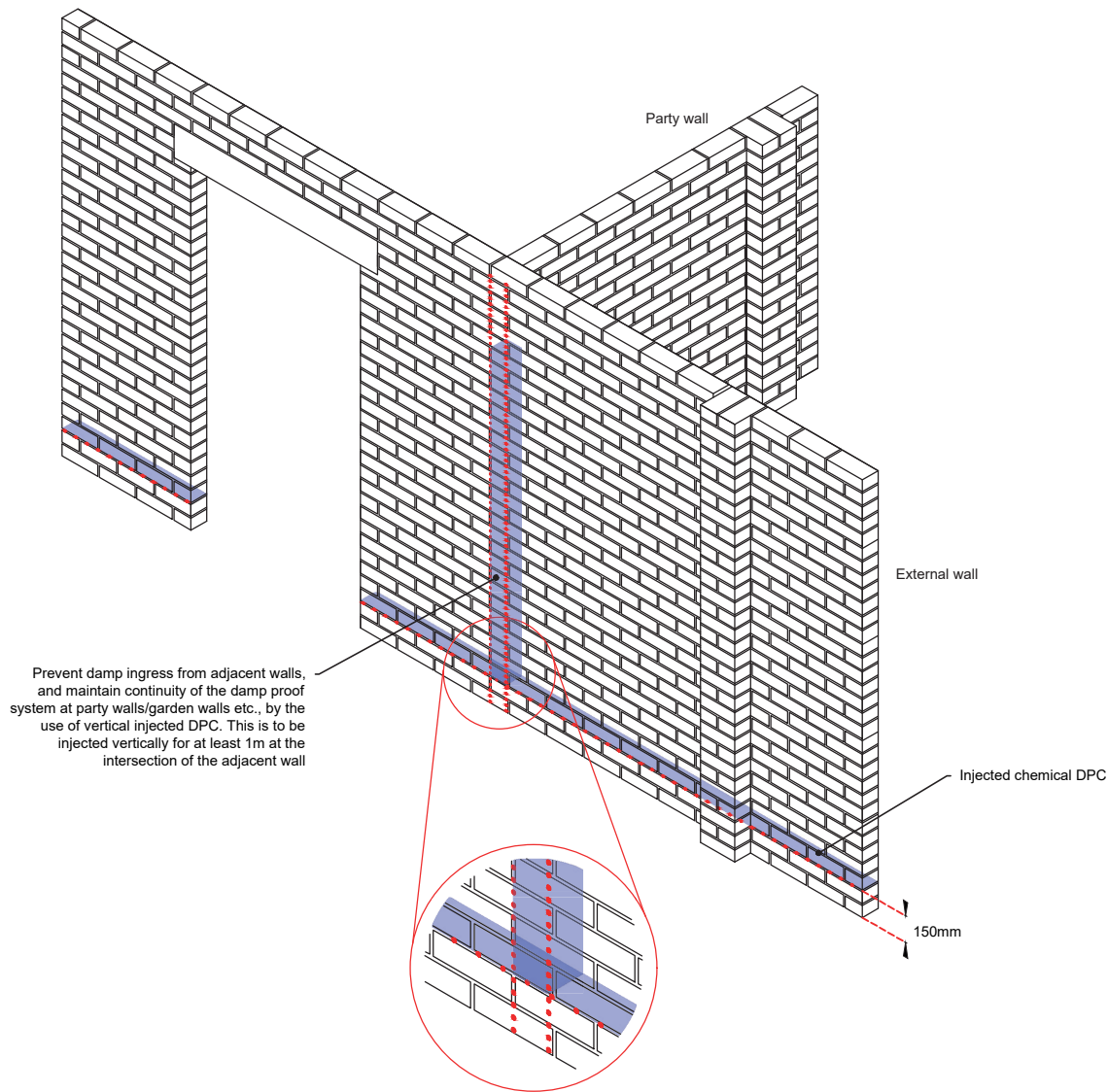

Damp proofing in walls

Where an existing DPC cannot be identified or is found to be defective, a remedial DPC should be provided; it should have an insurance-backed guarantee and be installed by a Property Care Association Member. A copy of the guarantees shall be provided for our records upon completion of any remedial treatment carried out.

A suitable DPC should be provided to existing walls, placed at least 150mm above external ground level to ensure that ground moisture does not enter the inside of the building. Consideration must be given to the height of the ground floor.

Some types of wall are not suitable for treatment by a remedial DPC system. These include:

- Walls of exceptional thickness i.e. greater than 600mm.
- Rubble-filled walls.
- Random flint/granite walls, or those of other similar impermeable materials.
- Mud walls (cob), wattle and daub.
- Rat trap bond.

Where it is not suitable to provide a remedial DPC, the wall should be assessed to demonstrate that it prevents rising dampness from entering into the building. The assessment should include the following:

- Damp Proof Survey from a member of the Property Care Association or RICS Chartered Surveyor to confirm that there is no evidence of rising damp and a copy of the report should be provided and retained for our records, and;
- Suitable detail of the ground floor construction and independent internal lining system that keeps the internal environment of the dwelling dry.

Advice should be sought from the a member of the Property Care Association as to the suitability of their proposed products/system. Products used in chemically injected systems should always hold current independent third-party certificates.

Condition and treatment of floor timbers

Where it is proposed to keep the existing ground floor, the existing floor boards/finish should be lifted to ascertain the condition of the timber joists/wall plates. A report compiled by a Structural Engineer must be provided to confirm that the floor construction will be adequate to take the proposed loadings. A specialist timber report by a member of the Property Care Association will also be required to identify if insect infestation and fungal attack is present and if so, what remedial treatment will be required. A copy of the report should be provided and retained for our records.

When deciding if an existing ground floor is adequate, there are a number of areas that should be addressed, including:

- An adequate DPC to walls/sleeper walls.
- All timbers must be free from rot and insect infestation.
- Adequate ventilation to the sub-floor (please note, many sub-floor voids will require cleaning out to achieve ventilation and reduce dampness).
- Adequate foundations supporting sleeper walls.
- Joists are of sufficient size and span.
- Are any load-bearing internal walls built off floor joists?
- Have joists been weakened by excessive notching or drilling?
- Adequate trimming to hearth.
- Adequate strutting of joist.

Strengthening an excessively notched joist

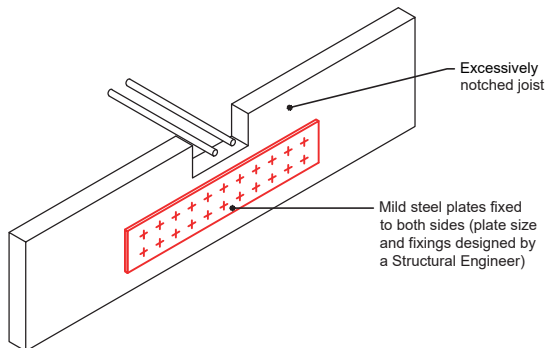

In order to obtain insurance, it is a Warranty requirement that an intrusive timber survey is undertaken to demonstrate the overall condition of timber members that are proposed to be retained. The survey should be completed by a member of the Property Care Association or a RICS Chartered Building Surveyor and should include the following:

- An intrusive investigation to identify the overall condition of the timber.
- Deep probe moisture readings where timber is embedded, to confirm that the timber remains durable at bearings.
- Causation and remediation of timber defects

The appointed preservation specialist is undertaking the detailed investigation of all timber members to identify the presence of any insect or fungal decay, and to treat the affected areas as appropriate.

It is essential that the type of fungal attack is correctly identified, as treatment methods vary for dry rot and wet rot.

The cause of both fungal and insect attack is elevated moisture levels, which may be caused by the following:

- Rain penetration.
- Condensation.
- Hygroscopic salts.
- Defective rainwater goods and roofs.
- Bridging of existing DPCs, or no DPC.
- Defective renders.
- Leaking drains and internal plumbing.
- Incorrect external levels.

Fungal attack is controlled by two sets of measures, primary and secondary. Areas that have not been inspected should be clearly identified to enable a subsequent inspection to be carried out when the structure has been fully exposed. This could include rafter feet and wall plates that are particularly prone to rot.

Primary measures

These consist of locating and eliminating sources of dampness and promoting the rapid drying out of the structure. Where the timber becomes wet and remains wet, e.g. the moisture content exceeds 20%, then it is likely to decay. By eliminating the source of dampness and the drying of timbers to below 20%, the fungus will normally stop growing and will eventually die.

Secondary measures

These consist of determining the full extent of the outbreak and a combination of:

- Removing all decayed timbers.
- Treating of walls to contain fungi within the wall (only applicable to dry rot).
- Treating of sound timbers with preservative on a localised basis where required.
- Using preservative-treated replacement timbers (pre-treated).
- Introducing support measures, such as isolating timbers from walls and the provision of ventilation between timbers and the walls.

Dry rot commonly occurs when timber is in contact with damp brickwork and where ventilation and heating are inadequate. Therefore, particular attention should be paid to cellars, basements and sub-floors, and also behind panelling.

Where buildings are considered to be historically significant, and there may be limitations placed upon what remedial treatments can be used, we advise that the services of a building conservation consultancy is used, who have the requisite experience in dealing with the conversion and refurbishment of historic buildings. Hutton & Rostron (Tel No. 01483 203221, www.handr.co.uk) have previously been appointed to carry out investigatory works and specify remedial treatments and have a good knowledge of our Warranty requirements. Alternative suitably qualified consultants can be used. The appointed consultant should be approved by our Technical Surveying department.

These expert consultants must be retained until the end of the project to verify that the works that they have recommended have been carried out to their satisfaction. Commencement and completion reports should be retained on our systems.

Where any remedial timber treatment is proposed, it shall be carried out by a registered member of the Property Care Association in accordance with their Code of Practice for Remedial Treatment and associated technical leaflets. A 10 year insurance-backed Warranty shall also be provided. A copy of the report and the 10 year insurance-backed Guarantee shall be provided and retained for our records.

Typical example of repairs to floor joists

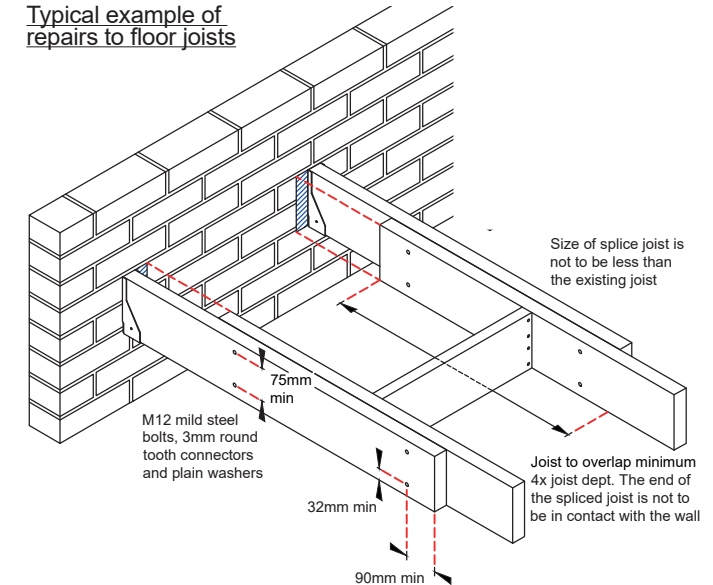

Ventilation to floor voids

Existing timber floors are required to be cross ventilated, this is often an issue where the existing building is to be split up into various building compartments. In such cases a ventilation strategy should be considered.

Options for cross ventilation could include:

- Intumescent air bricks.
- Vertical stack pipes that provide ventilation to the floor.

In both cases consideration should be given to the passage of fire and sound.

The void beneath the timber floor must be clear to allow a free flow of air beneath the joists and floor structure.

Existing solid floors

Only existing concrete floors are considered suitable for refurbishment, any stone, earth or tiled floors should be removed and replaced with a new concrete floor. Existing stone or tiled floor coverings may be used as a decorative finish.

Existing concrete floors will be required to meet the following requirements:

- That the floor has a suitable damp proof membrane. This has to be confirmed by a survey undertaken by a member of the Property Care Association. Where this cannot be confirmed a new DPM should be installed. A liquid applied membrane to the surface of the concrete would be suitable in most cases subject to the liquid membrane having appropriate third party certification. Note: Where existing slabs are cut for new drainage runs/service voids, it is not considered acceptable to carry out repairs to the existing DPM. A new DPM has to be installed.
- That the floor is free of any structural distress or movement. Where there are signs of movement, the floor should be replaced unless it can be proved by a Chartered Structural Engineer that the floor is suitable for carrying imposed loads and supporting its own weight without any further movement or cracking.

Structural repairs

Prior to undertaking structural repairs, it is essential that the root cause of the structural defect has been remedied by underpinning, addition of adequate lateral restraint, buttressing, etc. Strengthening works to the structure may also be necessary to accommodate increased or modified loads.

All assessment and design of remedial works must be carried out by a suitably qualified Structural Engineer and upon completion certified that the remediated structure will have a 60 year residual service life.

External walls

Solid walls

To provide an acceptable level of protection against the ingress of rain water, any retained solid masonry external walls should either:

- Be fully lined internally with an independent timber or metal stud wall.
- Be clad externally with a rain screen or other protective measure.
- Comply with the requirements of BS 5628 (as outlined below).

Typical independent internal lining

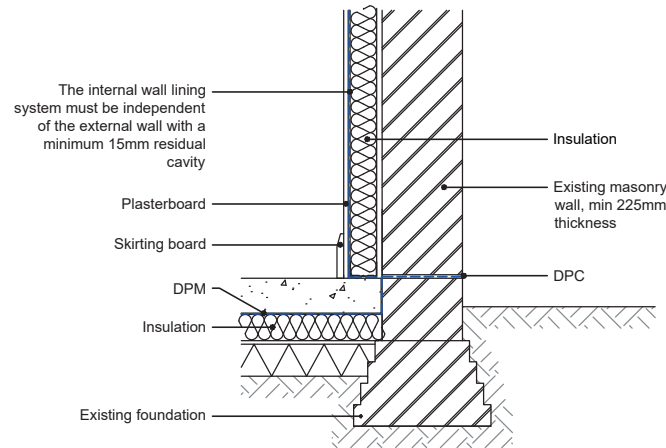

An independent lining system should also be provided where party walls between buildings, project above adjacent roof coverings (thus becoming external walls).

Where damage has occurred to walls, the cause needs to be investigated.

Likely reasons for the damage include:

- Ground movement - foundation failure, settlement, subsidence, chemical attack.
- Thermal movement - thermal expansion of wall due to temperature changes.
- Roof spread - pitched roofs not properly tied, spreading at eaves.
- External and internal walls not bonded together.
- Wall tie corrosion.
- Lintels inadequate over openings.
- Sulphate attack - water-soluble sulphates attack cement-based mortar, normally in a wet environment, i.e. below ground level and parapet walls.
- Frost attack.
- Bonding timbers present and subject to rot and shrinkage.
- Ineffective or no lateral support at floor and roof level.
- Moisture ingress.

Weather resistance of walls and cladding

Existing solid brick or stone walls are unlikely to be acceptable as weather-resisting, although consideration of the exposure category of the building and porosity of the masonry will be given, i.e. do existing non-gypsum-based internal linings allow for greater insulation and evaporation than gypsum plasters alone?

It is anticipated that in all buildings, at least one of the additional treatments noted below will be required, and this must include appropriate insulation.

However, all solid masonry wall situations may require a Specialist's report to identify the extent of any necessary remedial treatment. A copy of the report shall be provided and retained for our records.

External treatments

Existing claddings can be retained if it can be shown by a suitably qualified expert that:

- The system is maintaining the integrity of the building.
- It is adequately fixed and the expected life span of the fixings, where appropriate, is in excess of 15 years.
- The cladding material is free from any defects.
- Adequate provision for movement has been allowed.

A copy of the expert report shall be provided and retained for our records.

If the above situations cannot be satisfied, a new external cladding or render system will need to be installed.

Internal treatments

An alternative to preventing moisture penetration by using externally applied claddings and renders is to adopt internally applied methods.

Systems are available that are installed on the inside of existing walls to prevent moisture penetration reaching the internal accommodation. These include:

- Independent metal or timber framed systems: these should not be fixed to the existing masonry walls, but fixed at the 'head and base' to avoid direct contact. Ventilation should be provided to avoid a build-up of condensation between the masonry and the inner lining system.
- New internal walls: these would normally be formed in blockwork, must be adequately founded and, where necessary, tied to the retained and new elements of structure.

Control of damp penetration

Measures should be taken to ensure that thermal insulation in cavities does not encourage the passage of damp from the ground or from the exterior of the building to the inside of the building.

Thermal insulation of walls and claddings

Various methods exist to upgrade the thermal insulation of existing walls and floors. Regardless of the methods adopted, it is essential that risks associated with increased thermal insulation are minimised, including:

- Surface condensation caused by improvements to draught proofing of the building.
- Interstitial condensation caused by moisture-laden air passing from the dwelling to within the fabric of the structure and condensing on cooler surfaces.
- Increased risk of damp penetration caused by the filling of cavities with insulation.
- Maintaining the robustness of the external and internal wall surfaces by the provision of adequate mechanical protection over insulation materials, e.g. externally applied insulation systems with render coat mechanical protection.
- Avoidance of cold bridges around openings and where structural elements extend through the thickness of the building envelope.
- Repeating thermal bridging must be considered, e.g. internal metal-framed walls should be used in conjunction with thermally insulated plaster board.

Render and plaster application finishes

Plaster for conversions/refurbishment

Where the condition and bond of the existing plaster can be shown to be adequate, it can remain, with the exception of the following:

- Where rising damp is present.
- Where a chemical DPC is installed.
- At the junction of external walls and party walls to see if they are properly bonded.
- Above openings to examine the make-up and condition of lintels.
- Where there is a possibility that bond timbers may have decayed.
- Where the wall is solid and the plaster is gypsum-based.

Where a chemically injected DPC is installed, it is necessary to remove the plaster one meter above the DPC level or 600mm above any apparent salt line/dampness, whichever is higher. Re-plastering work should be delayed as long as possible in order to encourage rapid evaporation of residual moisture, and the building should be well ventilated during the drying period.

Plastering work must comply with an independent third-party certification and the chemical DPC must meet the manufacturer's recommendations. Recommended plasters usually incorporate adhesives to increase resistance to the passage of hygroscopic salts from the wall into the plaster. They should not, however, act as a vapour barrier. Gypsum plaster should not be used in conjunction with chemically injected DPC.

The plaster should not bridge the DPC or be in contact with the ground floor slab.

Final redecoration should not be carried out until residual moisture has disappeared. Matt emulsion paint is recommended for use during this period.

Internally drilled holes concealed by skirting boards, etc. should not be plugged. Other visible holes and external holes should be plugged.

Rendering for conversion/refurbishment

Where the condition and bond of the existing render can be shown to be adequate, it can remain, subject to the following exceptions:

- If the render bridges the DPC.
- Above door and window openings where it is necessary to examine the type and condition of the lintels.
- Where there are signs of structural movement in the building, and further investigation is required.

If the existing render finish is to be retained, this will be subject to a condition survey from an independent RICS Chartered Building Surveyor or other recognised specialist consultant. This report must state that in their professional opinion, the render is adequately bonded to the substrate and is likely to have a residual service life in excess of 15 years.

Where over rendering is proposed, the bond of the existing render must be assessed and details will be required on how the new and the old render are to be adequately bonded together. Therefore, a condition report will be required on the existing render as detailed above. A specialist render consultant must be employed to specify the new render make-up and demonstrate how the new and the old render are to be bonded together. Please note all new render works must be in accordance with the 'External Walls - Render' section of this Technical Manual.

Cracking in masonry walls

Minor cracking can be defined as cracking that occurs in the mortar joints and which does not extend through the masonry components. Providing that the crack is no wider than 4mm, and there has been no lateral displacement of the wall, the wall can be re-pointed.

Major cracking affects the structural integrity of the wall, and investigation should be undertaken by a suitably qualified structural Engineer to find the cause of the problem. Once any specified remedial works are carried out, the appointed Structural Engineer should confirm that the structure has a 60 year residual service life.

Walls out of plumb/bulging

Where walls are more than 25mm out of plumb or bulge more than 10mm within a storey height, a Structural Engineer should comment on the stability. The wall may need to be rebuilt or strengthening works undertaken.

Where it is intended to provide buttressing walls to support out of plumb and/or bulging walls, they should be designed by a suitably qualified structural Engineer. Once any specified remedial works are carried out the appointed Structural Engineer should confirm that the structure has a 60 year residual service life. In raised tie roofs (where no ceiling ties are provided at eaves level), lateral spread of the brickwork just below eaves level may have occurred because the roof has deflected. In such cases, it is necessary to prop the roof and rebuild the affected part of the wall.

Bonding timbers

These are common in Georgian buildings, and were laid in the internal skin of the wall to reinforce it and to provide fixings for panelling, etc. With the low compressive strength of lime mortar and general timber decay, the bond timber compresses under load. As the timber is on the inner skin, the compression causes bulging outwards, which may be apparent on the external face. Normally, bond timbers should be exposed during the conversion and removed in short lengths, and replaced with bonded masonry.

External and internal walls not bonded together

A common defect in properties up to the 1920s is the lack of bonding/tie of party walls to the external wall.

Different bricks and bricklayers were often used, with the poorer quality materials and labour being used on the party walls. This junction should be exposed when undertaking a conversion and if the bond is inadequate, a suitable stitching detail incorporated. A design by a suitably qualified Structural Engineer may be required supported by confirmation of the remedial works has a residual service life of 60 years.

Typical examples of rectifying unbonded walls

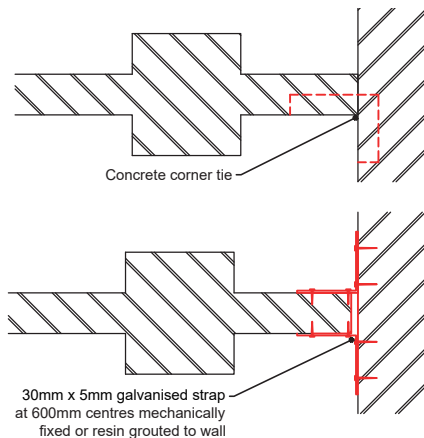

Arches and lintels

The existing timber lintels can be retained if they support the structural walls and it can be shown that the lintel is adequate for its purpose, i.e. there is no sign of any structural movement, loads will not be increased and the timbers are free from rot and insect infestation.

In order to ensure that any timber lintels are free from rot, all lintels should be

exposed at both ends and on the inner (hidden) face of the timber embedded in the wall for openings in external walls.

Where movement or decay has occurred and the timber lintel is inadequate, the lintel should be replaced with either a concrete or steel lintel.

Where cracking has occurred in masonry arches, it will be necessary to rebuild the arched construction. In cases where failure has occurred due to the low pitch of the arch, it may be necessary to incorporate a lintel.

Alterations to existing openings

Where existing openings are to be filled with masonry, the new work should be adequately bonded to the existing and the weather resistance of the wall maintained. However, if the opening then becomes part of a party wall it should comply with the requirements for sound insulation.

Cavity Walls

Wall tie corrosion

Cavity walls have been constructed since 1850, but it was not until 1920 that this form of construction was widely adopted. It is important when undertaking a conversion to confirm the construction of the external wall. In cases where headers are incorporated into the bond of the external brickwork, an investigation of the wall construction must be undertaken to clarify the actual wall make up and the Warranty surveyor advised of the findings. Many properties in the Victorian period were built with either a 215mm outer leaf and cavity behind, or a 215mm inner leaf, cavity and a half brick outer leaf with snapped headers.

Initial evidence of cavity wall failure can include cracking of bed joints in mortar (typically every sixth course). This is due to the expansion of the wall tie as it corrodes.

Bulging of the external leaf could also indicate that the ties have failed.

Where there is wall tie corrosion or inadequate ties, or where wall ties have corroded to an extent serious enough to threaten the stability of the wall or building, a suitably qualified Structural Engineer should be appointed to determine the necessary remedial works and state that the structure following the remedial works has a residual service life of 60 years.

Insulation to cavity walls

Most cavity walls constructed after 1985 should already be insulated, however where a cavity wall is required to be thermally upgraded, it should be lined internally. The retrofitting of cavity wall insulation is not acceptable as the overall condition of the cavity is not known. If blown insulation is already present within an existing cavity, additional measures to provide continuous thermal protection to all external walls will be required. This may be in the form of an independent insulated lining internally or external wall insulation. Furthermore, the condition of cavity wall ties should be checked for corrosion and suitability for retention.

Other structures

Timber Framed walls

Timber framed elements must be structurally durable and free from rot.

The timber frame must be assessed as part of any timber survey as described earlier in this guidance. Particular attention should be given to sole plates and timber framed elements that are close to the ground.

Curtain Walling

Curtain walling must be assessed by a cladding and façade specialist to determine the following:

- The structural durability of the façade.
- The adequacy of the façade in forming a suitable waterproof envelope.
- The fire performance of the façade, particularly with respect to external fire spread and ensuring cavity barriers are correctly installed in line with current Building Regulations.

No fines construction and other non-traditional methods

It is essential that any "no fines" construction is correctly assessed and tested to determine the durability and integrity of the structure by a suitably qualified Structural Engineer to determine the structure will have a residual service life of 60 years.

Internal walls and upper floors

Existing masonry

Where a wall is adequately founded or supported on a beam that shows no signs of distress, it can remain providing there is no increase in load onto the wall. Any increase in load should be justified by calculation by a suitably qualified Structural Engineer. New masonry supported on existing timber beams should be avoided.

In older properties, it is possible that fitch beams and Bessemer's may be supporting masonry walls, and these should be examined by suitably qualified Structural Engineer to ascertain their capability to carry the load.

Existing studwork

Many properties built before 1880 have trussed internal partitions, usually located approximately halfway back in the depth of the property. Often, these walls are load-bearing, continue up through the building and carry floor and roof loads onto the foundations.

If a timber partition is load-bearing, providing it is adequate, the loads are not being increased and the timber is free from rot and insect infestation, it can remain. Where there are defects i.e. the floor sags on the line of the partition and there is distortion of door heads, then additional strengthening works should be undertaken.

New door openings cut into an existing trussed partition should be overseen by a suitably qualified Structural Engineer, as this can adversely affect the triangulation of the truss.

Timber floors above ground level

Existing timber floor joists can be retained within the building, providing they are adequate for their purpose.

The following points should be considered:

- Joists are of sufficient size for the span.
- Load on the floor is not being increased.
- Joists have not been weakened by excessive notching and/or drilling.
- All timbers are subject to an intrusive survey, confirming the ends of joists are free from rot.
- All timbers to be treated for insect infestation and wood rot.
- No masonry walls are built off timber joists.
- Appropriate strutting is provided.

Filler joist floors

Many buildings of the late Victorian and Edwardian periods were built with floors constructed of clinker concrete supported by embedded iron or steel joists. The concrete produced with clinker aggregate was porous, and therefore provided poor corrosive protection to the metal.

When considering a conversion in a building with filler joist floors, it is important to first investigate whether the floors have been subject to damp conditions and whether any significant corrosion has taken place.

Particular attention should also be paid to ensuring that the floor remains dry during the conversion, and this could include providing a temporary covering if removal of the existing roof is necessary.

Rooms containing areas of high humidity use or potential areas where water spillage can occur, e.g. wet rooms, bathrooms, en-suites kitchens, utility rooms should not be constructed over such filler joist floors.

Where the scheme involves converting a concrete or steel-framed building into dwellings or other uses, the following guidance is given.

An appraisal of the existing building should be carried out by a suitably qualified Structural Engineer, taking into account the proposals for the change of use.

This will include:

- Condition of the structural frame, including joints.
- Proposals to increase loadings on the structure and foundations.
- Alterations to existing load paths.
- Alterations to stability systems.
- Changes in environmental exposure.
- Recommendations to cover additional reports and testing by Specialists.

The floor loads on the building may decrease, as they could be converted for domestic use only where previously they were, for example offices.

A statement from the Structural Engineer confirming, where appropriate, that the existing foundation design is acceptable for the new loads subject to the building showing no signs of distress, i.e. movement, cracking etc. will be acceptable in such circumstances.

Where the intention is to increase the load on the existing structure e.g. by the introduction of an additional floor, then structural calculations should be provided to prove the adequacy of the building and foundations.

In all cases, the Structural Engineer should confirm the building structure will achieve a 60 years life expectancy once the remedial works have been satisfactorily completed.

Concrete-framed buildings

Where the building is of concrete construction, a structural appraisal by a suitable qualified Structural Engineer is required. The survey and report is to be based on the recommendations made by 'TR54 - Diagnosis of determination of concrete structure - The Concrete Society' and 'IStructE guide for assessing concrete structures'. It is recommended that the Engineer comments on the following:

- Has overall loading assessment been undertaken.
- Assessment of existing foundations is essential.
- The assessment needs to consider disproportionate collapse.
- Additional testing is required for carbonation, chloride attack, presence of High Alumina Cements and Alkali Silica reaction. The Structural Engineer to provide us with outline testing proposal for our review.
- Require confirmation of a residual service life of 60 years

Steel-framed buildings

In addition to any structural reports, a visual inspection of the steel frame should be carried out to assess the extent of any corrosion of the framework.

Where corrosion is present, accurate measurements can be made using an ultrasonic gauge. Data collected can be used to compare the thickness of steel sections against the original steelwork drawings, British Standards and the Historical Structural Steelwork Handbook to ascertain if the structural frame is adequate for the proposed loads.

Where steelwork has corroded, further analysis must be sought to determine if any expansion of the frame will/has occurred. In such scenarios, cathodic protection may need to be considered which will be required to be carried out by a suitably qualified expert confirming that a 60 year residual service life will be achievable once the works have been completed.

Steelwork generally

Exterior steelwork: should be inspected; where corrosion is visible, the steel can be grit blasted, cleaned and re-coated.

Perimeter steelwork: in direct contact with the outer leaf of the building can be prone to corrosion, particularly in older properties. A sign indicating that this has happened is the displacement of the external masonry due to the expansion of the steelwork caused by corrosion. During the conversion process, the appropriate repairs/replacement should be carried out.

Interior steelwork: normally, corrosion of unprotected steelwork within the interior of a building is low, with only superficial rusting. Providing that a visual inspection confirms this, and the environment intends to remain dry, no further treatment of the steel will be required. Where the proposals involve the steelwork in a 'wet' environment, such as kitchens and bathrooms, it should be adequately protected.

Bimetallic corrosion

This should be considered in the existing and proposed structure.

Bimetallic corrosion occurs where two different metals are in electrical contact and are bridged by water or water containing other chemicals to form an electrolyte. A current passes through the solution from the base metal to the noble metal and, as a consequence, the noble metal remains protected and the base metal suffers increased corrosion.

Where there is a possibility of this occurring, or if it has already occurred, advice should be taken from a Specialist on how to deal with it.

Cast iron, wrought iron and mild steel structures

Many older buildings that are converted into dwellings or other uses, e.g. warehouses, cotton mills etc. were built using cast iron, wrought iron or mild steel.

When the intention is to keep the existing structural elements, an appraisal of the existing building is necessary.

In addition to this, the Engineer should comment on the following:

- Determine the age of the building and the materials used.
- Assess how its construction has fared.
- Justify the loadings by calculation.
- Identify areas where additional testing and/or opening up is necessary.

If the proposed loads remain unchanged or are reduced, as will probably be the case, and it can be shown that the existing structure has not suffered any deterioration due to corrosion or deflection of structural members etc. the building may only require localised structural alterations.

Where the intention is to increase loads, carry out major structural alterations or the existing building is under-designed, a Structural Engineer should comment on this and provide calculations to justify the proposals.

Surveying roof timbers

All roof timbers shall be subject to an intrusive timber survey, undertaken by a member of the Property Care Association and provide a report detailing any necessary treatment to be carried out. Particular attention should be given to rafter feet, wall plates and valley timbers, as these often show signs of rot.

Roof structure

It is essential that the roof structure has adequate strength, stiffness and dimensional accuracy appropriate for the new roof covering. All strengthening work should be designed by a suitably qualified Structural Engineer that will result after the work has been completed that the roof structure will have a residual service life of 60 years.

Common problems encountered include:

- Excessive spans of rafters, purlins, binder and ceiling joists.
- Inadequate ties between rafters and ceiling ties.
- Insufficient number of collar ties at purlin level.
- Decay of rafter feet and valley beams.
- Settlement of purlin supports.
- Lateral spread of raised-tie roofs.

Roof coverings

Traditional slate and tiled roofs

Roofs should generally be re-covered in accordance with the 'Roofs' section of this Technical Manual. Where roofs are to be re-covered, it is required that existing gable walls are appropriately supported during the construction works and lateral restraint straps are fitted to any gable walls.

There may be exceptional circumstances where an existing tiled roof covering can be retained; however the following requirements would apply namely:

- That the tiled roof shows no sign of deterioration that suggests that the roof covering has passed its useful life.
- That the roof has a suitable roofing membrane/roofing felt beneath the tiles which is functioning correctly and not damaged.
- That ridges and hips are well bedded and mortar has not eroded. Please note, it may be reasonable in some circumstances that ridges and hips are re-fitted, mechanical fixing should also be provided in such circumstances.
- That timber laths and nails are in good condition and fit for purpose.
- That existing flashings and weatherings are assessed, particular attention should be given to valleys and parapets, if there is any doubt of the condition of any weatherings, they should be replaced.

Please note:

1. A report should be provided on the condition of the tiles and stating that they have a residual service life of at least 15 years. The report should be by a suitably qualified expert.
2. Fibre cement tiles would generally not be accepted for retention.
3. Adequate provision for ventilation to the roof voids should be considered.
4. The requirements for resisting fire spread in the relevant Regional Building Regulations must be considered e.g. how will fire stopping at heads of party walls etc. be achieved?
5. Wet bedded hips and ridges must be demonstrated to be adequately fixed or if found to be poorly bedded then they should be stripped and mechanically fixed (or if subject to listed restriction then they should be re-bedded in accordance with BS 5534).
6. All parapets should be removed, new DPMs provided and re-fixed with mechanical fixings. Inside face of parapets to be waterproofed, lined lapped under DPM etc.

Continuous membrane roofs, and balconies and terraces (forming a roof)

Membrane roofs, balconies and terraces (forming a roof) should be re-covered in accordance with the 'Roofs' and 'Balconies and Terraces' sections within this Technical Manual unless the following provisions can be met:

- That the existing membrane is less than five years old and is tested for water ingress and a condition report is provided to confirm a remaining residual service life of at least 15 years will be achieved (testing guidance requirements can be found in the 'Roofs' and 'Balcony and Terraces' sections of this Technical Manual).
- There are no signs of excessive ponding.
- The roof has a fall, adequate upstands and suitable drainage outlets.
- That balconies and terraces are fitted with overflows.
- That any thermal upgrade via inverted insulation does not compromise roof drainage or upstands.

Windows and Doors

Where windows and doors are replaced they should be replaced in accordance with the 'Windows and Doors' section of this Technical Manual.

Any retained windows and doors must meet the following provisions:

- Should be no more than 15 years old.
- Be in good condition and free from any damage, rot or decay.
- Be able to perform as part of the waterproof envelope.
- Provide adequate ventilation where the building ventilation system relies on purge ventilation.
- That window mechanisms and catches operate correctly.

The Technical Services Surveyor reserves the right to accept or reject the retention of existing windows as part of their Refurbishment Assessment.

D.

Appendix D

D.2

Conversions and Refurbishments - New Elements Connecting to Existing Structures

Introduction

Where new developments are attached to existing buildings, and the existing elements that form part of the new structure must meet the Functional Requirements of the Warranty. The details below give some guidance on the minimum information and standards required to meet the Functional Requirements.

Party Wall Agreement

It is highly likely that improvements to an existing wall are necessary to meet the requirements of the Warranty. This may include underpinning, injected DPC and internal linings.

Where a wall is shared by two or more owners, the requirements of the Party Wall etc. Act may apply. This is separate legislation with different requirements to the Building Regulations or Warranty requirement. Further guidance on the Party Wall etc. Act can be found on the Planning Portal website www.planningportal.gov.uk

Separating walls

The separating wall between the new and existing building must meet the relevant requirements of the regional Building Regulations.

Confirmation should be provided where the existing wall is to be upgraded to meet current regional Building Regulations, particularly in meeting the relevant sound insulation and fire separation requirements. The structural integrity of the existing wall and its resistance to ground moisture should also meet current standards.

Existing foundations

The existing foundations and wall structure must be suitable to support any proposed increased loading resulting from the construction of the new building.

Foundations to the existing wall should be exposed and assessed for suitability to support additional loadings. It is important to protect existing foundations at all times, and care must be taken not to 'undermine' existing foundations when clearing the site or reducing levels.

Where existing foundations require underpinning, a design by a suitably qualified Structural Engineer should be provided and approved by the Warranty Surveyor prior to work commencing on-site.

The existing wall should also be appraised by a suitably qualified Structural Engineer to determine whether it is structurally stable and suitable to support additional loadings.

New wall junctions

The junction of the new walls to the existing walls must ensure that dampness cannot track back into the new building or existing building. The detailing of this junction is critical to ensure that moisture ingress does not occur between the new and existing walls. Typical acceptable details are shown to the right.

Damp Proof Course (DPC)

An effective DPC should be present in the existing wall, linked to the new DPC and Damp Proof Membrane (DPM) of the new building.

Acceptable existing DPCs are considered as:

- A continuous felt or proprietary DPC material.
- A chemically injected DPC supported by an insurance-backed guarantee.
- A slate DPC is considered acceptable if the existing wall incorporates an independent wall lining system to the inner face of the new building.

The new DPC should lap the existing DPC by at least 100mm.

Existing and new structure junctions

At the junction of the existing and new structures, detailing should allow for differential movement without cracking. Any settlement should be limited to 2mm-3mm, which would not normally adversely affect the roof covering.

Typical details of bonding new walls to existing are indicated to the right.

In order to prevent excessive differential movement, the new building should have the same foundation type as the existing building. Where the foundation types are different, e.g. new building pile and beam, existing building traditional strip foundation, the new building should be completely independent of the existing building.

The foundation design should be confirmed by a suitably qualified structural engineer and a copy of the report provided to the Warranty surveyor before construction works commence.

Bonding new walls to existing solid masonry wall

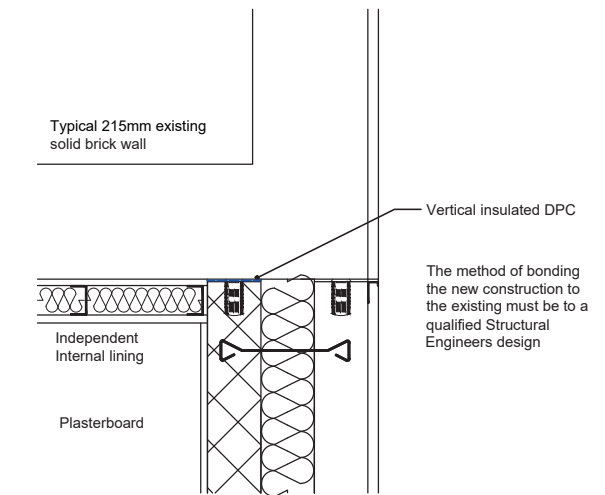

Bonding new walls to existing masonry cavity wall

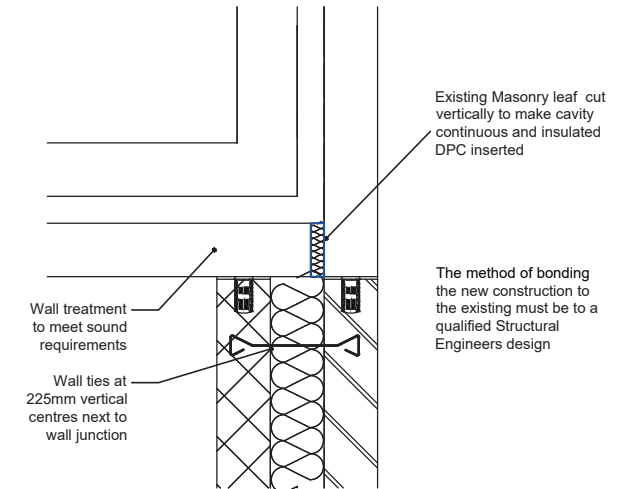

D.

Appendix D

D.3

Conversions and Refurbishments - Buildings with Historic Significance

Introduction

The guidance that follows is for buildings that have Historic or Conservation Planning restrictions, where due to such restrictions it is not possible or feasible to upgrade the building.

The guidance in this section is applicable to those elements that cannot be improved or altered, in all cases there are some types of construction that will not be suitable for warranty cover these are as follows:

- Grade 1 listed buildings
- Scheduled and ancient monuments
- Former agricultural buildings of any nature, with the exception of the farmhouse
- Barns
- Cob construction
- Through wall oak/timber frame
- Wattle and daub

Conversions and refurbishments are projects that involve work to existing buildings or parts of existing buildings. This could include the conversion of industrial or commercial buildings into housing; the conversion of an existing residential building into flats; an additional storey to an existing building; the refurbishment of an existing residential building; or a façade retention project.

The Warranty includes cover for the retained structural elements and water proof envelope of any existing building for the duration of the policy. Any conversion or refurbishment will be the subject of a Refurbishment Assessment by our Warranty Technical Surveyors and this should occur before you start planning or building.

The Warranty Surveyor will always undertake an initial assessment of the existing fabric to ascertain in general terms if the proposal is capable of representing a standard risk to the Underwriter. If deemed acceptable, the development is then subject to a technical audit process during construction, and the following guidance is intended to assist all parties in ensuring the relevant requirements are met, as well as providing an element of consistency in approach.

Depending on the condition of the original building; an expert survey may be required for the different elements of the building as described in the following guidance. If the survey concludes that any of these elements are unable to achieve a residual service life of 60 years for structural elements and 15 years for non-structural elements, they should be systematically replaced or repaired.

Existing buildings and structures can present particular problems both initially and on an ongoing basis. Therefore, it is essential that thorough and comprehensive survey work is undertaken prior to new works commencing to understand both the current condition of any structure and the impact any proposed works may have. Although initially this may be considered an unnecessary early expense, the savings in reconstruction costs can greatly outweigh the cost of the preparatory work.

Elements of the retained structure and proposed works should not be considered in isolation, as a solution for one problem may cause issues elsewhere. Past performance is no guarantee of ongoing adequate performance because different expectations and changing living conditions can all impact on both the actual and perceived performance of a converted/refurbished structure.

It is not possible to cover every building type within this guidance. The guidance is general and certainly will not apply in every scenario. It is strongly recommended that early discussions are held to determine the exact requirements and to enable a full review of the proposed strategy and development.

Where new work is proposed, it should follow the guidance for those elements in the various Building part sections earlier in this Technical Manual. Where new work is applied to, or meets, existing elements, consideration on how these areas will interact must be made; for example, new cavity masonry that abuts an existing solid wall construction. If works have progress to a stage beyond where it is not possible to survey the structure or that new works have been carried without inspection, it is highly likely that the scheme cannot be considered a standard risk and the offer of warranty may be withdrawn.

Please note that the requirements of the technical audit are quite different from those undertaken for the purposes of compliance with Building Control and Planning legislation. If any such bodies have imposed restrictions on the areas above, we suggest that you contact the Technical Services Department before undertaking any works.

Retained elements, foundations and load-bearing structures (including floors, walls and roofs)

Planning Restrictions

Where building renovation or thermal upgrade is limited by planning restrictions, a copy of the planning permission and supporting conditions must be provided.

The Structure

The guidance in 'Appendix D – Conversions and Refurbishments - Existing elements' equally applies to this section.

Damp Proof Course's (DPC) and Damp Proof Membranes (DPM)

The guidance in 'Appendix D – Conversions and Refurbishments - Existing elements' equally applies to this section.

Timber treatment against insect and fungal attack

The guidance in 'Appendix D – Conversions and Refurbishments - Existing elements' equally applies to this section.

Roof coverings

The guidance in 'Appendix D – Conversions and Refurbishments - Existing elements' equally applies to this section.

Weather resistance of walls, including claddings, render, re-pointing, etc.

The guidance in 'Appendix D – Conversions and Refurbishments - Existing elements' equally applies to this section.

External doors and windows

The guidance in 'Appendix D – Conversions and Refurbishments - Existing elements' equally applies to this section.

Sound testing

The guidance in 'Appendix D – Conversions and Refurbishments - Existing elements' equally applies to this section.

Drainage

Drainage systems should be replaced unless it can be demonstrated that the existing drainage system is fit for purpose, have suitable falls and the required rodding facilities.

Where private drains are retained, a CCTV survey should be undertaken to ensure the integrity and design of any retained system. Where the lengths of existing retained drainage do not have rodding access in accordance with current requirements, additional access points should be provided. Inspection chambers and manholes located within habitable parts of the building will not normally be acceptable. Existing septic tanks and cesspools should be replaced with a new sewerage treatment system.

Where some of the elements are new and replaced as part of the conversion/refurbishment, no report is necessary.

Substructure

Foundations

The guidance in 'Appendix D – Conversions and Refurbishments - Existing elements' equally applies to this section.

Basement Structural Waterproofing

Please refer to 'Appendix D - Conversions and Refurbishments - Existing Elements', and also the 'Basements' section in the main body of this Technical Manual for further guidance.

Where a basement area on a converted or refurbished site is not habitable, any damp/water ingress occurring is specifically excluded from the Policy.

Excluded is; water entry, dampness or condensation to the enclosing walls, floors and ceilings of any underground: car-parking and any associated underground refuse stores, cycle stores, plant rooms (that do not house items of plant that directly service the building and for which the failure of such plant would prevent the normal use of the Home), lifts/escalators, associated access stairs and lobbies; where a continuous structure entails the conversion, refurbishment or renovation of an existing building(s) and where the structural integrity of the building is not affected.

Walls

Damp proofing

For details of remedial DPCs please refer to 'Appendix D - Conversions and Refurbishments - Existing Elements' which applies to damp proofing.

Where planning restricts the inclusion of an independent lining system and where it is not feasible to insert a chemical injection DPC, a full assessment must be completed by Chartered Building Surveyor who has proven experience in historic and Listed Buildings (RICS Accredited Building Conservation Surveyor or equivalent). The assessment must identify the risk of rising damp and propose solutions where applicable.

Condition and treatment of floor timbers

The guidance in 'Appendix D - Conversions and Refurbishments - Existing Elements' applies also to this section.

Existing solid floors

The guidance in 'Appendix D - Conversions and Refurbishments - Existing Elements' applies also to this section.

Superstructure

Structural repairs

Prior to undertaking structural repairs, it is essential that the root cause of the structural defect has been remedied by underpinning, addition of adequate lateral restraint, buttressing etc. Strengthening works to the structure may also be necessary to accommodate increased or modified loads.

External walls

Solid walls

Where walls cannot be upgraded in accordance with the guidance in 'Appendix D - Conversions and Refurbishments - Existing Elements', and where the existing thickness of the external wall does not meet the required exposure rating in BS 5628, a full survey of the wall will be required by a Chartered Building Surveyor with proven experience in Historic and Listed Buildings (RICS Accredited Building Conservation Surveyor or equivalent). The report should not only identify the potential issues or defects but also provide solutions to ensure that the external walls remain durable.

The specialist Historic Building Surveyor services must be retained until the end of the project and verify that the works that they have recommended have been carried out to their satisfaction.

The report should include the following information:

- Overall condition of the existing external walls.
- The quality of existing mortar.
- The quality of existing masonry with respect to the durability of bricks/stone/render.
- Potential high risk areas or areas of concern where there is potential for future water ingress with particular attention focussed towards the following:
 - a) Parapets.
 - b) Roof/wall abutments.
 - c) Penetrations and openings.
 - d) Stone feature-work.
 - e) Window and door reveals.
 - f) Rain water outlets and rain water pipes.

The following information should accompany the building survey:

- A scope of works clearly identifying any remedial measures.
- Details of any ongoing maintenance requirements for the walls.
- Confirmation of the level of supervision during the remediation process.

It should be noted that although the external walls may be proven as acceptable without independent internal lining systems, particular attention should be given to window and door reveals and it is likely that in all cases an independent lining will be necessary to window heads, cills and reveals. Consideration can be given where the reveals are already lined such as oak panelling adjacent to existing sash windows providing that the lining is free from dampness and decay and is considered in the above report requirements.

Internal walls

The guidance in 'Appendix D - Conversions and Refurbishments - Existing Elements' equally apply to this section.

Timber floors above ground level

The guidance in 'Appendix D - Conversions and Refurbishments - Existing Elements' equally apply to this section.

Other framed buildings

The guidance in 'Appendix D - Conversions and Refurbishments - Existing Elements' equally apply to this section.

Filler joist floors

The guidance in 'Appendix D - Conversions and Refurbishments - Existing Elements' equally apply to this section.

Timber roofs

Surveying roof timbers

The guidance in 'Appendix D - Conversions and Refurbishments - Existing elements' equally applies to this section.

Roof structure

The guidance in 'Appendix D - Conversions and Refurbishments - Existing elements' equally applies to this section.

Roof coverings

Traditional slate and tiled roofs

The guidance in 'Appendix D - Conversions and Refurbishments - Existing elements' equally applies to this section.

Continuous membrane roofs and balconies and terraces (forming a roof)

The guidance in 'Appendix D - Conversions and Refurbishments - Existing elements' equally applies to this section.

Windows and doors

Where existing windows and doors have to be retained due to planning and conservation restrictions but do not meet the guidance in 'Appendix D - Conversions and Refurbishments - Existing Elements', the following information must be provided to determine adequacy of performance:

- A full survey of the windows and doors by a suitable specialist to determine the current condition and the windows and doors ability to be resistant against water ingress for 15 years.
- Where windows are to be repaired, a full repair schedule must be provided detailing the extent of the repairs. A completion report from the suitable specialists shall be provided, confirming the repairs are adequate and that the windows will now have a residual service life of not less than 15 years.
- Full details of the window repair specialist must be provided. The repair specialist must demonstrate that they have suitable experience for the specialist repairs of windows and doors.
- Where the window and door system includes feature stone mullions, full details prior to any repairs being carried must be provided to confirm that the mullions are resistant to moisture and will have durability against water ingress for at least 15 years.

T 0800 183 1755 E enquiries@labcwarranty.co.uk

www.labcwarranty.co.uk

MD Insurance Services Ltd. is the scheme administrator for LABC Warranty and is authorised and regulated by the Financial Conduct Authority. Registered in England No: 3642459. **TS-011A-10.00-110621**

