



# TECHNICAL MANUAL

VERSION 11

**5: DRAINAGE**

# 5. Drainage

## Contents

### Functional Requirements

- 5.1 Above Ground - Foul Drainage
- 5.2 Above Ground - Storm Drainage
- 5.3 Below Ground - General requirements
- 5.4 Below Ground - Foul Drainage - to Mains Sewer
- 5.5 Below Ground - Foul Drainage - to Septic Tank
- 5.6 Below Ground - Storm Drainage - to Mains Sewer
- 5.7 Below Ground - Storm Drainage - to Soakaway

## Limitations of Functional Requirements

1. These Functional Requirements do not and will not apply to create any policy liability for any remedial works carried out by the contractor or otherwise, nor to any materials used in those remedial works
2. The guidance provided in this section, is guidance that provides a suggested solution to meeting the Functional Requirements. If an alternative solution is selected, then this must still meet the Functional Requirements.

## Workmanship

1. Drainage systems should be laid strictly in accordance with the design requirements.
2. All work is to be carried out by a technically competent person in a workmanlike manner.
3. Concreting shall not take place during cold weather periods where the working temperature is below 2°C or where ground conditions are frozen.

## Materials

1. Drainage materials must meet a recognised standard such as a Eurocode or British Standard.
2. Below ground drainage systems should be backfilled with suitable materials so as not to cause any damage to the drain by loading or crushing.
3. All materials should be stored, installed and protected correctly in a manner that will not cause damage or deterioration of the product.
4. All materials, products and building systems shall be appropriately tested and approved for their intended purpose.
5. All load bearing structural elements providing support to the Home will have a service life of not less than 60 years, unless specifically agreed otherwise with us. All other parts of the Home will have a lesser durability and need planned maintenance, repair or replacement during that reduced period.
6. All materials should be suitable for the relative exposure of the building in accordance with the relevant British Standards.

## Design

1. The outfall drainage from any sewerage treatment plant or septic tank, should discharge to a suitable outfall that has been given full consent to do so, in writing from the appropriate regional agency.
2. Drainage layouts and systems must be supported by a full design package identifying drainage diameter sizes, gradients and outfalls.
3. All drainage services - shall be designed, constructed and installed so that they:
  - a. Do not adversely affect the structural stability of the building;
  - b. Do not adversely affect the durability or compromise the weather proof envelope;
  - c. Prevent the entry of hazardous ground substances, external moisture or vermin;
  - d. Are constructed using non-hazardous materials;
  - e. Are durable and robust;
  - f. Are safe and convenient in use;
  - g. Liquid and solid waste is discharged safely and efficiently to a suitable outfall;
  - h. The systems are adequately accessible for inspection and cleaning;
  - i. Designed so that the risk of blockages is reduced;
  - j. The system is adequately vented;
  - k. Noise transmission from pipes is reduced to a minimum.
4. The design and specifications shall provide a clear indication of the design intent and demonstrate a satisfactory level of performance.

# **5.**

## **Drainage**

### 5.1

#### Above Ground - Foul Drainage

### Provision of information

A full set of design drawings and specifications shall be made available to the Warranty Provider and all other interested parties prior to the associated works starting on site. This may include:

- Proposed drainage layouts including invert levels, gradients, pipe diameters, location of inspection chambers and rodding points.
- Position of ventilation to the foul drain.
- Specification of drainage pipes and supports.
- Location and size of cold water storage cisterns and hot water storage cylinders.
- Hot and cold water pipe runs.

The Warranty Surveyor, at their discretion, may also request supporting information that demonstrates suitability for use of any materials or systems contained within the above.

### Above ground soil and waste drainage systems

Drainage shall be designed, constructed and installed so that:

- Pipework should be designed to meet the requirements of relevant Building Regulation requirements or BS EN 12056-Parts 1, 2 and 5, and be installed following the guidance in BS 8000 - 13.
- Connected to a suitable underground foul drainage system.
- The materials and components used for sanitary pipework, e.g. pipes, fittings and fixing accessories, should conform to appropriate European Standards or European Technical Assessments (ETAS). Where no relevant European Standard or ETA exists, British Standards or British Board of Agrément Certificates should be used.
- Sanitary pipework should be installed in accordance with manufacturer's recommendations.
- Pipework used externally must be suitable for exposure to sunlight without early degradation. Proof of use for external exposure must be provided.
- Do not adversely affect the structural stability of the building.
- Prevent the entry of hazardous ground substances, external moisture or vermin.
- Are constructed using non-hazardous materials.
- Are safe and convenient in use.

All above ground plumbing systems need to be designed to allow the unobstructed flow of waste water from an appliance to the underground drainage system. To achieve this, the points below should be noted at the design and installation stages:

- Provide rodding access facilities at all changes of direction.
- Avoid bends, connections and changes of direction in the wet part of the above ground drainage system.
- Pipe sizes are adequate to take the expected rate of discharge and load at suitable gradients with the minimum of direction changes.
- 75mm deep seal traps should always be used, except:
  - On a WC where a 50mm depth of water seal can be used, or
  - Where an appliance on the ground floor discharges directly into a trapped gully.
- Pipe sizes should not exceed the dimensions for diameter against pipe length.
- Pipes should be laid at gradient 1:80 or better and adequately supported to prevent sagging and back falls.
- Sanitary pipework must be adequately supported (see Table 1).
- Provision for expansion in the pipework must be given both in vertical pipes and branch/waste pipes (see Table 2).
- Any admittance valve fitted to the system should be located above the highest flood level of any appliance connected to that stack pipe.
- Enclosures to air admittance valves should be adequately ventilated.
- The highest point of a drainage system (head of run) should always be vented to the external air.
- A soil or ventilation pipe should extend at least 900mm above an opening if it is less than 3m away from an opening into the building.
- The drains are adequately protected from ground loads and movement in the

building structure.

- Drains and pipes passing through the external waterproof envelope of the building or through the underground walls must be suitably sealed to prevent vermin ingress and dampness.
- Sound insulation will be necessary where soil pipes pass through rooms to the underground connection. This can be achieved by:
  - Encasing the pipework within a boxed in framework with a minimum 15 kg/m<sup>2</sup> board covering or
  - Wrapping the pipework with mineral wool fibre at least 25mm thick, throughout the height of the pipe - up to the highest ceiling level.

**Table 1: Max distance between sanitary pipe supports**

Pipe material	Normal pipe size (mm)	Vertical pipes (m)	Low gradient pipes (m)
Plastics (any type)	32 to 40	1.2	0.5
	50	1.2	0.6
	75 to 100	1.8	0.9
	150	1.8	1.2
Cast iron	All sizes	3.0	3.0
Copper	25	2.4	1.8
	32 to 40	3.0	2.4
	50	3.0	2.7
	65 to 100	3.7	3.0
Galvanised steel	25	3.0	2.4
	32	3.0	2.7
	40 to 50	3.7	3.0
	65 to 75	4.6	3.7
	100	4.6	4.0

**Table 2: Design for thermal movement in runs of waste pipes**

Fitting type	Movement provision
Push fit	Push fit joints should be assembled with clearance for expansion. Check expected movement and relate to number of joints
Solvent-welded joints	Provide 'push-fit' couplings at calculated intervals, but not exceeding 1.8m

#### Notes:

- The manufacturer's recommendations should be followed in respect of provision of movement (Polypropylene pipe work can expand more than UPVC pipework for the same length).
- Ensure 'push-fit' joints are lubricated before assembly with specified lubricant that is approved for the pipe type. (Boss white is not permitted to make joints in plastics pipework).
- Sleeve wastes through walls to permit pipe movement.

### Position of connections to soil stacks

A branch creates a no connection zone on a stack. No other branch may be fitted such that its centre line falls inside a zone, but its centre line may be on the boundary of the zone.

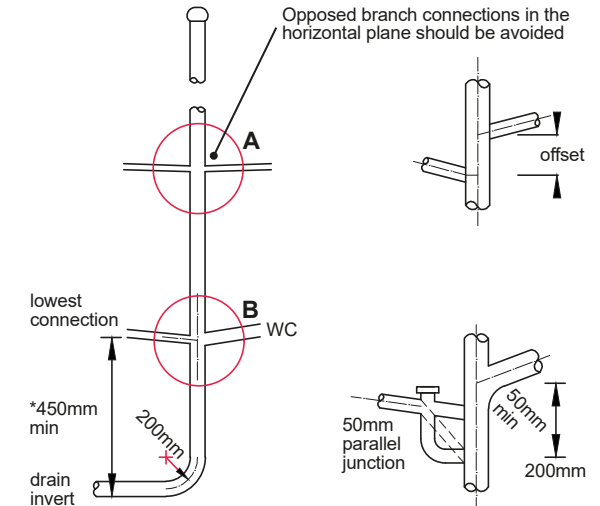

Key

**A** - Opposed connections without swept entries not exceeding 65mm should be offset:

- 110mm on a 100mm stack
- 250mm on a 150mm diameter stack

Opposed connections larger than 65mm (without swept entries) should be offset at least 200mm irrespective of stack diameter. Unopposed connections may be at any position.

**B** - Angled connection or 50mm diameter parallel junction where a branch discharge pipe would enter the WC no connection zone.

Note: A waste (branch discharge pipe) manifold may be a suitable alternative.

\*this should be increased in buildings over 3 stories.

### Openings for pipes in fire resisting floors and walls

Pipes which pass internally through fire resisting floors and walls (unless in a protected shaft) must not compromise the required fire resistance of the element through which they pass. As a minimum, openings through floors and walls should be as few as possible in number, as small as practicable in size and fire-stopped to the surrounding construction.

For pipes passing through compartment walls or floors, guidance supporting the Building Regulations in the relevant UK nation will need to be consulted for additional provisions.

### Single stack system: Air admittance valves

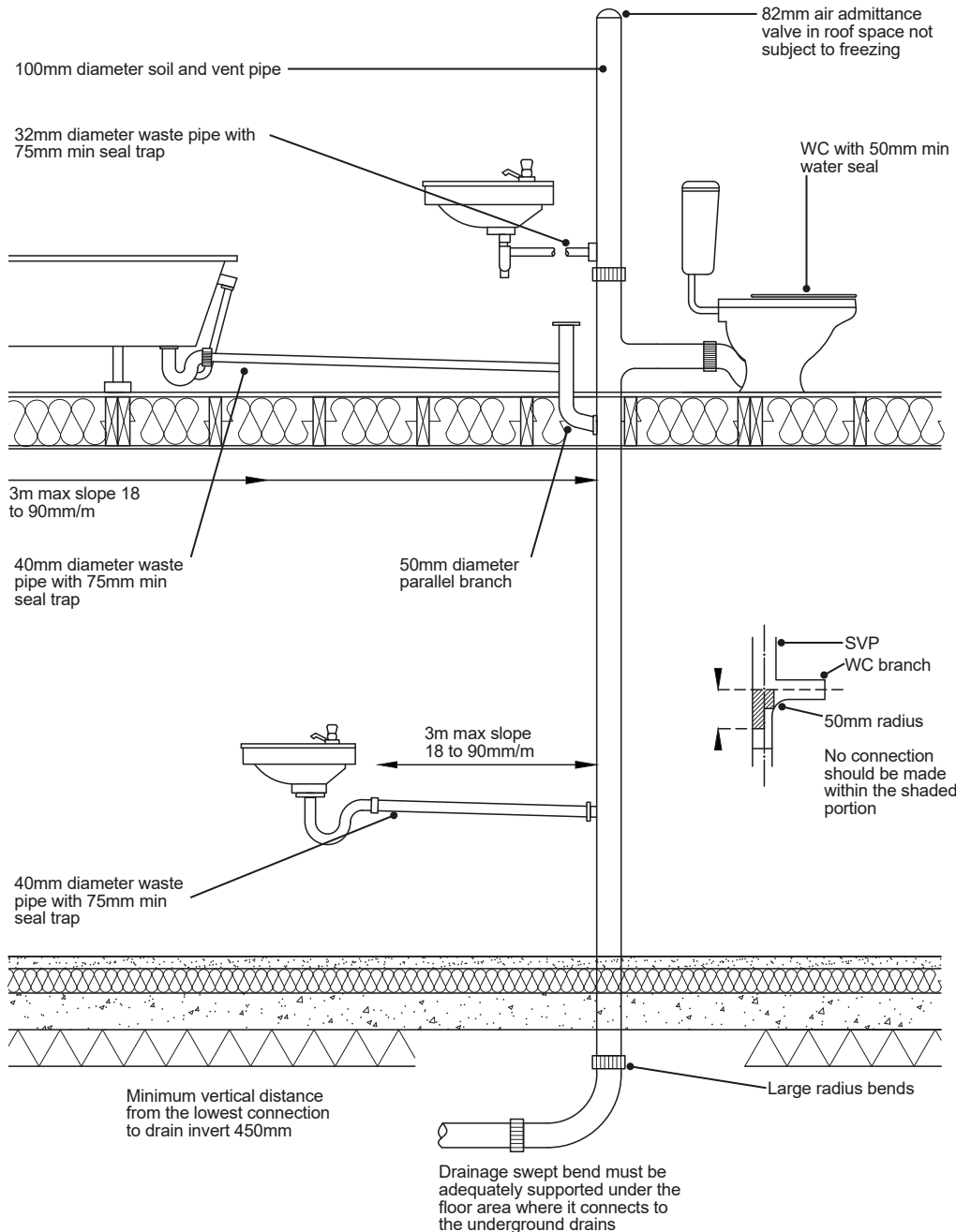

### Air admittance valves

Air admittance valves provide a means of ventilation to the drainage system to prevent the loss of water seals in traps. They are suitable for use in buildings, e.g. bungalows, houses, multi-storey flats, and they only allow air to enter the drainage system. Their use does not avoid the need to ventilate the drainage system adequately.

Where air admittance valves are used to terminate soil pipes, they should comply with Building Standards. Admittance valves must have a current third party product approval and be used within the scope of that approval certificate.

Valves within the building should be:

- Positioned in areas that are not liable to freezing.
- Positioned in areas with adequate ventilation. Note, where the pipes and valve are boxed in, adequate means of ventilation will be required by means of grilles or gaps. The amount of ventilation provided should be at least 2500mm<sup>2</sup> or whatever specified by the manufacturer.
- Accessible for maintenance.

If the discharge stack provides the only ventilation to septic tanks or cesspits, the connecting drain is subject to periodic surcharging or is fitted with intercepting traps, air admittance valves are not suitable for providing ventilation in these circumstances.

### Sanitary fittings

Wash basins (WHB), baths, bidets, shower trays:

- Should be securely fixed with appropriate non rusting fixings.
- Floors should be capable of carrying the weight of the appliance.
- Excessive packing must be avoided.
- Must be connected to the drainage system and where applicable an appropriate water supply.

Where WC's, WHB's, baths and shower units are installed; where tiling is installed around these appliances, flexible waterproof mould resisting flexible sealant should be used to accommodate any movement between the appliance and tiles.

Baths and shower units should be correctly supported so that when in use the fittings will not deflect excessively and pull on the mastic seal.

Floor joists should be doubled up under the bath locations. Where heavier baths (e.g. cast iron baths or similar) are proposed, the floor joists must be designed to take the additional loadings and joist feet located over the joists.

### Additional requirements where the development is within a coastal location

Where developments fall under the coastal location definition (see 'Appendix B - Coastal Locations') the following additional requirements should be met, and where elements of the sanitary drainage may be subject to the outside atmosphere, the following conditions will apply.

#### Corrosion

The materials should be suitably protected against corrosion, see 'Appendix C - Materials, Products, and Building Systems' for further information.

#### Fixings

External fixings that are exposed to weathering, moisture and corrosive environments or applications where concentrations of corrosive agents may accumulate should be made from high grade austenitic stainless steel (e.g. A4) or a protective coating suitable for the corrosion category described in the table 'the classification of environmental corrosion conditions' in 'Appendix C - Materials, Products, and Building Systems'.

#### Durability

External soil and waste pipes must be suitable for the environmental conditions. Please refer to the manufacturer's specifications to confirm durability. Discolouration of dark plastic goods may be unavoidable in coastal locations.

Due to the environment, certain materials and particularly the finishes may require on-going maintenance in order to keep a satisfactory finish e.g. external SVP. In these circumstances it will be the building owner's responsibility to ensure that regular maintenance of exposed components and finishes is undertaken to ensure they perform correctly. Maintenance plans will need to be in place during the lifetime of the building to ensure premature failure of coatings or components is avoided.

### Macerators and pumps

When installing macerators and such pumps to above ground drainage the following must be considered:

- The electrical installation must be carried out by a qualified person.
- The system must be installed in accordance with the manufacturer's guidance.
- The system should be flushed through several times after installation and prior to first use.
- The client will need to be provided with details of appropriate maintenance, servicing and cleaning for the system on completion of the installation.

# **5.**

## **Drainage**

### **5.2**

#### **Above Ground - Storm Drainage**

### Provision of information

A full set of design drawings and specifications shall be made available to the Warranty Provider and all other interested parties prior to the associated works starting on site. This may include:

1. Areas of roof drained to each gutter.
2. Downpipe and/or drainage hopper positions from roof.
3. Positions of hazards e.g. Flues, opening windows/doors.
4. Location of below ground storm drainage connections.
5. Rodding access provision.
6. Downpipe outlet positions - avoiding potential water ingress/splashing of external walls etc.

The Warranty Surveyor, at their discretion, may also request supporting information that demonstrates suitability for use of any materials or systems contained within the above.

### Provision of gutters and downpipes

Drainage shall be designed, constructed and installed so that:

- Roof water gutters and downpipes designed to meet the requirements of relevant Building Regulation requirements and BS EN 12056-3 The exception would be where we require a higher standard.
- Connected to a suitable underground drainage system.
- Materials and components for rainwater goods, e.g. gullies, pipes, fittings and fixing accessories, should conform to appropriate European Standards or European Technical Assessments (ETAS). Where no relevant European Standard or ETA exists, British Standards or British Board of Agrément Certificates should be used.
- Rainwater goods should be installed in accordance with manufacturer's recommendations.
- Pipework used externally must be suitable for exposure to sunlight without early degradation. Proof of use for external use must be provided.
- Do not adversely affect the structural stability of the building.
- Prevent the entry of hazardous ground substances, external moisture or vermin.
- Are constructed using non-hazardous materials.
- Are safe and convenient in use.

When designing roof drainage systems it is normally impracticable to guard against very infrequent extremely heavy rainfall events. The design should achieve a balance between the cost of the roof drainage system and the frequency and consequences of flooding. The effective design area of a drained roof / balcony area should be determined using Table 1.

If the roof area is greater than 6m<sup>2</sup>, a roof will need to be provided with rainwater gutters and rainwater downpipes (RWP) that meet the minimum size requirements shown in Table 2.

Where a roof area is less than 6m<sup>2</sup>, thought should also be provided to the provision of rainwater drainage of such roof areas e.g. dormer roofs so as to ensure rainwater will be effectively disposed and not cause potential for damage and resulting water ingress into the building. Note: Roof areas e.g. flat roofs, which are less than 6m<sup>2</sup> will still require to be laid to a fall.

**Table 1: Calculation of roof area**

Type of surface area	Effective design area
Balcony areas	Plan area
Flat roof plan	Area of roof
30° roof pitch plan	Area x 1.29
45° roof pitch plan	Area x 1.5
60° roof pitch plan	Area x 1.87
Pitched roof over 70° or any wall	Elevational area x 0.5

**Table 2: Gutter sizes and outlet sizes**

Max effective roof area (m <sup>2</sup> )	Gutter size (mm diameter)	RWP outlet size (mm diameter)	Flow capacity (litres/sec)
6	-	-	-
18	75	50	0.38
37	100	63	0.78
53	115	63	1.11
65	125	75	1.37
103	150	89	2.16

### Gutters

- Gutters should be laid to a nominal gradient of between 1mm over 1 metre and 3 mm over 1 metre where practicable.
- The gradient of an eaves gutter shall not be so steep that the gutter drops below the level of the roof to such an extent that water discharging from the roof will pass over the front edge of the gutter.
- Gutters must be adequately supported and not sag: Fascia or rafter brackets should be typically no more than 1 metre apart or as recommended by the manufacturer.
- Additional support for gutters will be required at angles, corners, and outlet positions.
- Gutters should be laid so that any overflow in excess of the design capacity - caused by extreme conditions such as above normal rainfall, will be discharged clear of the building. On flat roofs, balconies, valley gutters and parapet gutters, additional outlets may be necessary.
- In areas where snow lies on roofs, the front edge of the gutter should not be higher than the projected line of the roof, unless snow guards or other precautions are used.

### General requirements for above ground storm drainage

The above ground storm system needs to be designed to allow the unobstructed flow of storm water from the drained roof area to the underground drainage system. To achieve this, the points below should be noted at the design and installation stages:

- Pipe and gutter sizes should be adequate to take the expected rate of discharge, and are laid at suitable gradients with the minimum of direction changes.
- Discharge of gutters into downpipes can be substantially improved by the careful location of downpipes:
  - Locating downpipes at end quarter positions will double the flow capacity if more than one downpipe is required.
  - The downpipe should be located within 200mm of the change in direction in order to maintain the flow capacity of the gutter where changes in the line of the gutter occur.
- Where the design incorporates valley gutters or parapet gutters, the design should be carried out in accordance with BS EN 12056.
- Ensure that joints in gutters, gutter outlets and downpipes are sealed in accordance with the manufacturer's recommendations.
- Gutters and downpipes must be installed to allow for thermal movement. Joint gaps must be to the manufacturers recommendations.
- Downpipes must be installed plumb and supported at regular centres throughout the height of the pipework.
- Outlets should be correctly positioned relative to gullies.
- Sanitary pipework must not be connected/discharged into the storm drainage system.
- Pipework shall not reduce in diameter in the direction of flow, except in the case of siphonic systems.
- Siphonic roof drainage systems should be designed in accordance with BS EN 12056-3.
- Rainwater pipes from higher roof levels should not discharge onto a lower flat roof or balcony.
- Where a rainwater downpipe discharges into a gully, it should terminate below the gully grating but above the water seal, preferably by the use of a back inlet.



### Additional requirements for pitched roofs

(Please also refer to the 'Roofs - Pitched' guidance)

- Gutters should be fixed with the centre line vertically below the edge of the roof covering. Pitched roof UV resistant underlay should dress over the gutter.
- Gutters must be designed to deal with concentrated loads e.g. from nearby downpipes discharging water from higher level roof areas such as dormers.

Ensure gutters are:

- Adequately supported to prevent sagging.
- Laid to a fall towards the outlets.
- Have stop ends fitted.

### Tile edge over gutter centre line

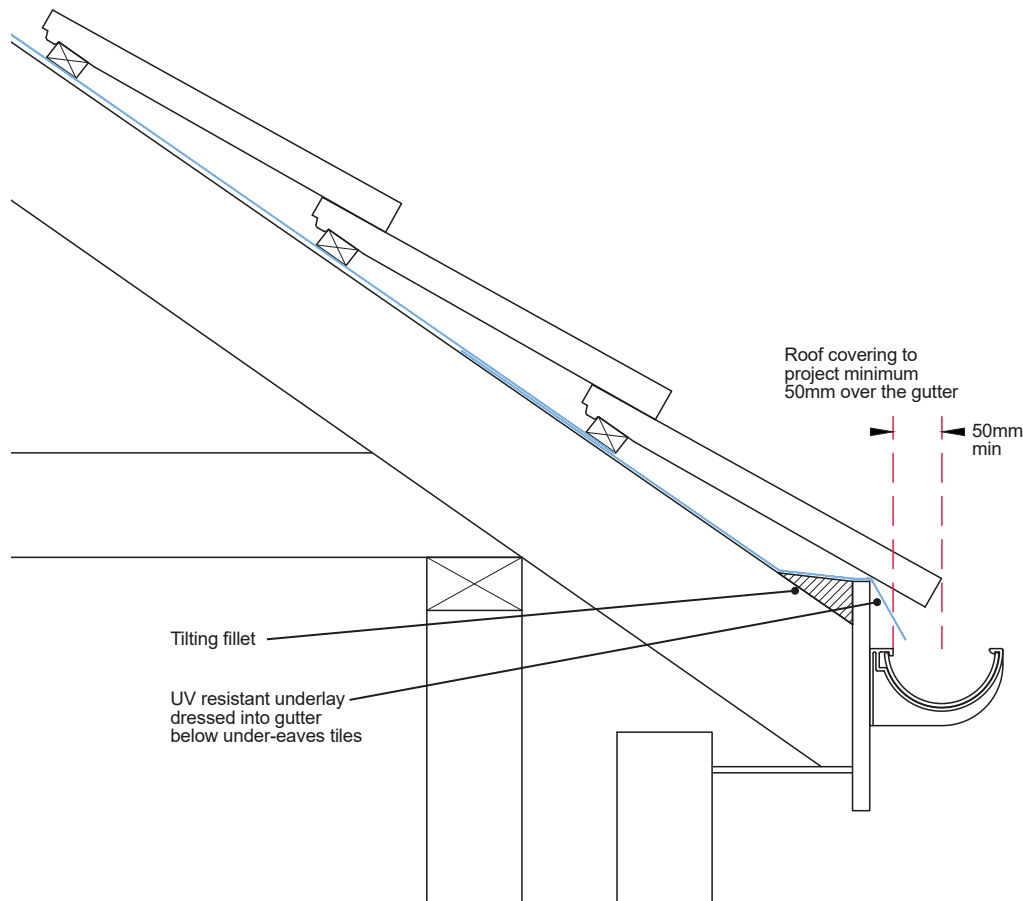

### Additional requirements for flat roofs and balconies

(Please also refer to the 'Roofs - Flat Roofs' and 'Roof Terraces and Balconies' guidance)

- To ensure effective drainage of the 'roof area', balcony decking or other finish laid over the water proof roof covering must not restrict water flow to the rainwater outlets e.g. decking supports must not be laid across the fall of the roof.
- Flat roofs and balconies must be designed and constructed to have a finished fall (allowing for deflection in the construction) of no less than 1:80.
- The roof area should fall away from a wall that contains any door/window opening and a minimum upstand of 150mm provided between the waterproof decking and the underside of the opening.
- Tapered insulation and 'crickets' must only be designed and manufactured by the insulation manufacturer (not cut to fall on site).

Rainwater outlets must be:

- Recessed and not stand proud above the flat roof water proof covering; to ensure water will flow freely into the outlet.
- Be accessible for maintenance (any decking above the outlet must easily be removable).
- Sized and be of sufficient numbers and position to deal with the local rainfall intensity in accordance with BS EN 12056-3.
- There must be 2 outlets (or one outlet plus one overflow) where the flat roof/balcony has an upstand to all sides.
- Drainage from roof gardens should enable inspection and access to the outlet and shall incorporate means of excluding soil and debris from entering the roof drainage system.
- Drainage outlets formed through parapet walls must be constructed with secondary protection to prevent water ingress into the wall structure.
- Drainage outlets formed through parapet walls in timber framed construction where the outer leaf is masonry; Must allow for shrinkage in the timber frame i.e. the frame will settle but the outer leaf will not, therefore a backfall could result in the outlet.

### Additional requirements where the development is within a coastal location

Where developments fall under the coastal location definition (see 'Appendix B - Coastal Locations') the following additional requirements should be met, and where elements of the surface water drainage may be subject to the outside atmosphere, the following conditions will apply.

#### Corrosion

The materials should be suitably protected against corrosion, see 'Appendix C - Materials, Products, and Building Systems' for further information.

#### Fixings

External fixings that are exposed to weathering, moisture and corrosive environments or applications where concentrations of corrosive agents may accumulate should be made from high grade austenitic stainless steel (e.g. A4) or a protective coating suitable for the corrosion category described in the table 'the classification of environmental corrosion conditions' in 'Appendix C - Materials, Products, and Building Systems'.

#### Durability

External surface water drainage components must be suitable for the environmental conditions. Please refer to the manufacturer's specifications to confirm durability. Discolouration of dark plastic goods may be unavoidable in coastal locations.

Due to the environment, certain materials and particularly the finishes may require on-going maintenance in order to keep a satisfactory finish e.g. gutters and downpipes. In these circumstances it will be the building owner's responsibility to ensure that regular maintenance of exposed components and finishes is undertaken to ensure they perform correctly. Maintenance plans will need to be in place during the lifetime of the building to ensure premature failure of coatings or components is avoided.

### Openings for pipes in fire resisting floors and walls

Pipes which pass internally through fire resisting floors and walls (unless in a protected shaft) must not compromise the required fire resistance of the element through which they pass. As a minimum, openings through floors and walls should be as few as possible in number, as small as practicable in size and fire-stopped to the surrounding construction.

For pipes passing through compartment walls or floors, guidance supporting the Building Regulations in the relevant UK nation will need to be consulted for additional provisions.

# **5.**

## **Drainage**

### 5.3

#### Below Ground - General Requirements

### Provision of information

A full set of design drawings and specifications shall be made available to the Warranty Provider and all other interested parties prior to the associated works starting on site. This may include:

1. Position of soil stacks.
2. Location of foul drain connections and drainage runs.
3. Location of suitable outfall.
4. Proposed drainage layouts including invert levels, gradients, pipe diameters, location of inspection chambers and rodding points
5. Where existing drains are retained, a CCTV survey will be required

The Warranty surveyor, at their discretion, may also request supporting information that demonstrates suitability for use of any materials or systems contained within the above.

### Swept connections into flow of drains – Acceptable

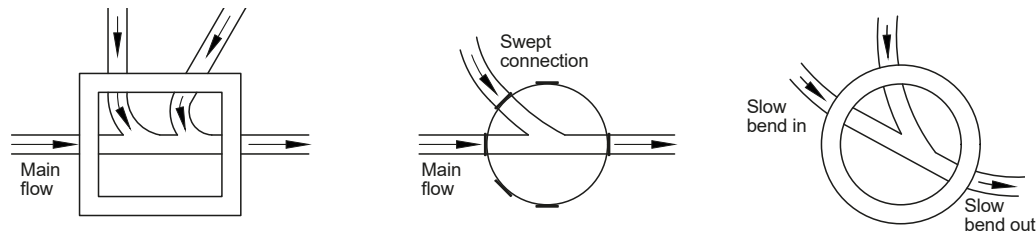

### Swept connections into flow of drains – Not Acceptable

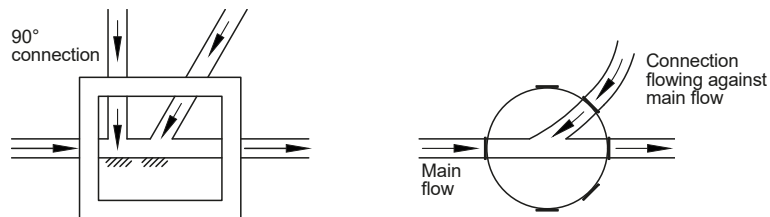

### Access and connections

Suitable access must be provided to every length of drain to allow rodding access to deal with potential blockages.

Depending on the depth and position of the drain, one of the following should be provided:

- Rodding eye - capped extensions of pipes.
- Access chamber - small chambers on (or an extension of) the pipes but not with an open channel.
- Inspection chamber - chambers with working space at ground level.
- Manhole - deep chambers with working space at drain level.

The installation of access points must not impede the flow of waste and allow connections onto main runs to be in the direction of flow and not against it.

### Additional requirements for drains near trees

Drainage near trees should incorporate additional provisions where there is a volume change potential within the ground. The provisions include:

- Increased falls to cater for any ground movement.
- Deeper and wider backfill of granular material.
- A drainage system that is capable of movement should heave and shrinkage occur.
- Drainage pipes should not be encased in concrete.
- Additional clearance is required where drains pass through the structure of a building to allow for additional movement.

Access points must be provided:

- On or near the head of each drain run, and
- At a bend and change of gradient, and
- At a junction unless each run can be cleared from an access point (some junctions can only be rodded through from one direction).

Minimum dimensions for access fittings, inspection chambers and manholes can be referenced in the guidance supporting the relevant Building Regulations.

Construction of access points should be with one of the following materials (see table 2) and must be capable of containing the foul water under working and test conditions.

Inspection chambers and manholes should have removable non-ventilating covers of durable material (such as cast iron, cast or pressed steel, precast concrete or plastics) and be of a suitable strength for its location e.g. access points on driveways will require heavier duty covers than those in a garden.

Small lightweight covers should be secured to deter unauthorised access.

Access points within buildings should have mechanically fixed airtight covers.

### Drainage system covers

Drainage system access point covers in hard standing areas should be level with the adjacent ground level.

Access covers in garden areas should not be covered over by the soil/turf.

### Materials for access points

Materials - access pipe	British Standard
Inspection chambers and manholes:	
Clay bricks and blocks	BS 3921
Vitrified clay	BS EN 295, BS 65
Concrete - precast	BS 5911
Concrete - in-situ	BS 8110
Plastics	BS 7158
Rodding eyes and access fittings (excluding frames and covers)	As pipes ETA or Third party product approval certificates

### Junctions in drains under buildings

Drains under a building must be laid in straight runs – slight curves can be accepted, providing the length of the run can be effectively cleaned by the use of rods. Having junctions under a building makes it difficult to clear any blockages, however they can be accepted in some very limited circumstances.

If Y-Junctions are used, they should only be used in the following circumstances:

- Where the branch drain discharges lightly soiled waste such as a wash hand basin, shower or bath, a Y junction may be used to connect to another drain under the building.
- The main drain should extend the full length of the building and external rodding access is provided at both ends of the main drain (see diagram for further details).
- If this is not achievable, an alternative rodding access point can be provided at the head of the main drain which terminates inside the building.
- Branch drains carrying heavily soiled waste are provided with a roddable stub stack. This should not involve removing any sanitary fittings or boxing (so an access plate should be provided).

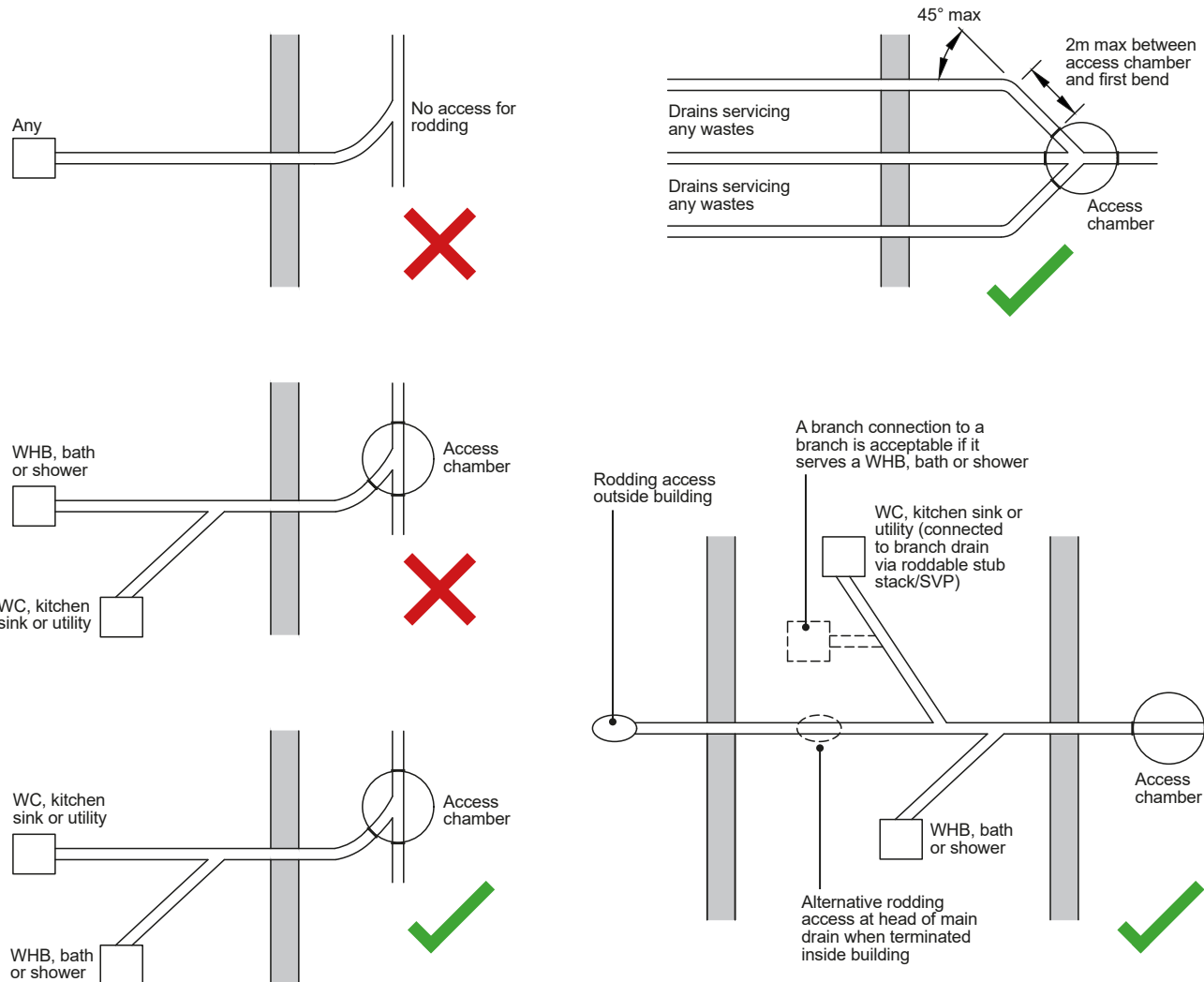

**General back fill**

In normal circumstances, the excavated material from the trench will be appropriate for backfilling above the chosen material. General backfill materials must be free from:

- Boulders.
- Building rubble.
- Timber.
- Vegetable matter.

Backfill needs to be positioned in layers not deeper than 300mm, and must be well compacted. When compacted backfill is at least 450mm above the crown of the pipe, only mechanical compacting should be used.

**Drain protection adjacent to foundations**

Drains are to be located so that foundation loads are not transmitted to pipes. Where drainage trenches are located near to foundations, foundation depths should be increased or the drain re-routed further from the foundations.

The trench should be filled with concrete to an appropriate level where the bottom of a trench is below foundation level.

**Drainage positions situated within angle of repose and adjacent to foundation by 1m**

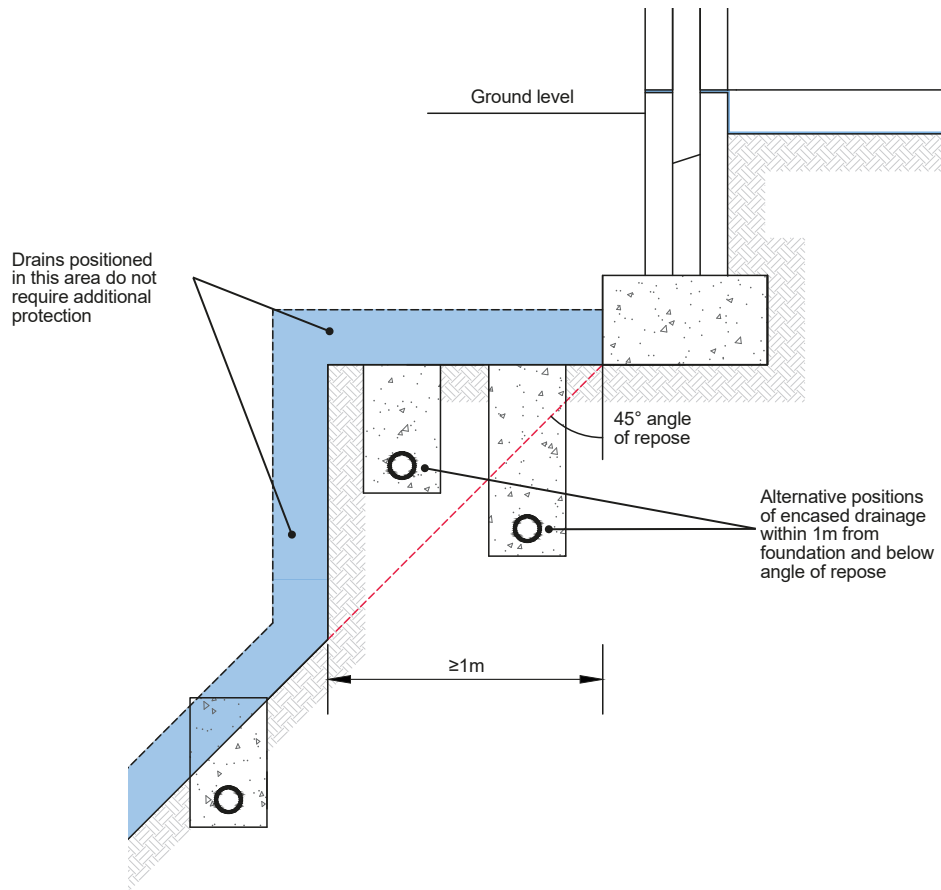

**Drains and services passing through walls**

Walls should accommodate movement where drains pass through substructure by:

- Providing a minimum 50mm clearance all around.
- A sleeve with a 50mm clearance.
- (If built in) A connection on both sides of the wall to pipes with flexible joints located no more than 150mm from the face of the wall.
- Any void formed between the pipe and the wall should be masked either side of the wall to prevent vermin access.

**Lintel openings over pipes**

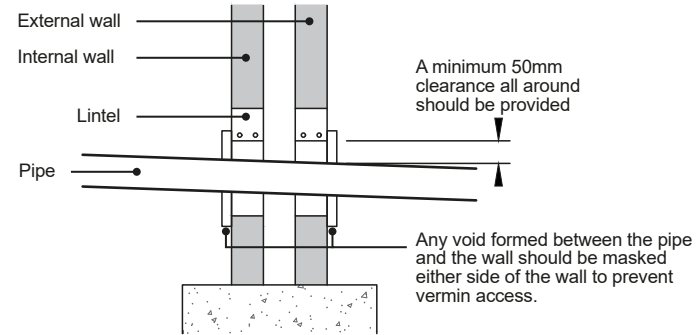

**Flexible jointed pipes (rockers) either side of built in pipe**

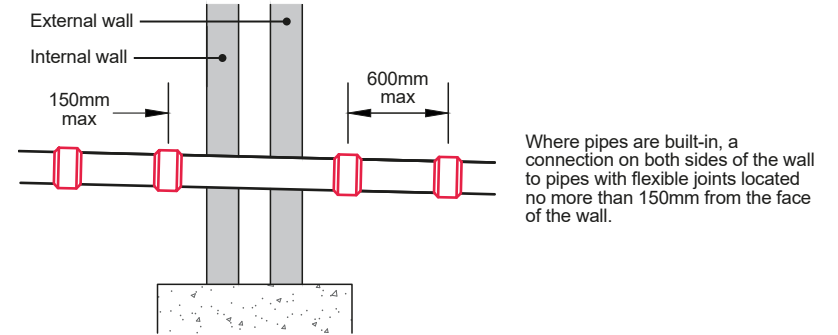

**Lintel opening for service pipes**

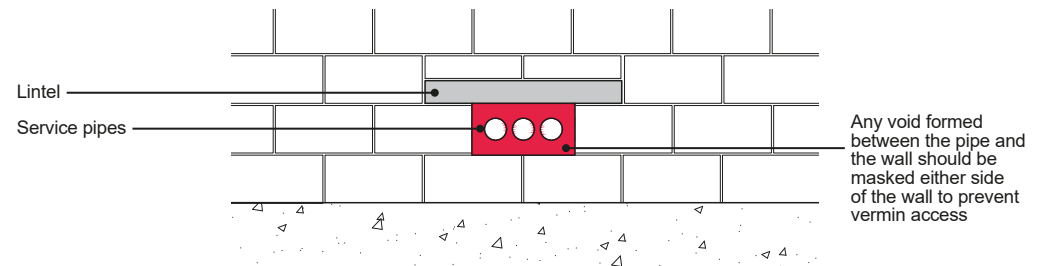

# 5. Drainage

5.4  
Below Ground -  
Foul Drainage -  
to Mains Sewer

### Provision of information

A full set of design drawings and specifications shall be made available to the Warranty Provider and all other interested parties prior to the associated works starting on site. This may include:

1. Position of soil stacks.
2. Proposed drainage layouts including invert levels, gradients, pipe diameters, location of inspection chambers and rodding points

The Warranty surveyor, at their discretion, may also request supporting information that demonstrates suitability for use of any materials or systems contained within the above.

### Below ground foul drainage systems

Drainage shall be designed, constructed and installed so that:

- Foul drainage systems should be designed to meet the requirements of relevant Building Regulation requirements or BS EN 752 and be installed following the guidance in BS 8000-14.
- Discharges to a suitable outfall which is:
  - Sewer maintained by the Local sewerage undertaker or
  - A suitable private foul drainage/sewer system (1) that leads to an adopted sewer.
- Note: (1) Connections to private foul drainage systems will require agreement of the owners of such drain/sewer.
- Materials and components used for foul water drainage systems, e.g. pipes, fittings and fixing accessories, inspection chambers etc. should conform to appropriate European Standards or European Technical Assessments (ETAs). Where no relevant European Standard or ETA exists, British Standards or British Board of Agrément Certificates should be used.
- Pipework, fittings, inspection chambers etc. should be installed in accordance with manufacturer's recommendations.
- Drains and pipework etc. must be durable and suitable for use underground.
- The installation of drainage/pipework does not adversely affect the structural stability of the building.
- Prevent the entry of hazardous ground substances, external moisture or vermin.
- Are constructed using non-hazardous materials.
- Are safe and convenient in use.

All below ground foul drainage systems need to be designed to allow the unobstructed flow of waste water to a suitable approved outfall. To achieve this, the points below should be noted at the design and installation stages:

- Foul water drainage systems only take foul waste from a property or properties and will include waste water from sinks, toilets, showers, baths, dishwashers and washing machines. These systems discharge into Local Authority sewers, then pass through sewage treatment plants. Storm water should be discharged to a separate storm water disposal system so as to avoid treatment plants treating large volumes of storm water needlessly.
- Drainage from impervious surfaces such as drives, paths and hard standings must drain to a suitable rain water drainage system.
- The drainage system, including manholes, gullies, pipe connections, etc. should be protected from damage throughout the course of the construction works.
- Drainage trench excavations should be taken down to solid ground, but when this is not possible, the drainage system should be designed to accommodate any movement and made-up ground with a well-compacted backfill to the required formation levels.
- Where ground movement is likely to occur, flexible drainage systems should be provided, e.g. filled sites, mining areas and sites with shrinkable clay.
- Where possible, avoid passing adjacent to tree roots. Adequate precautions should be taken where this cannot be avoided, in accordance with the recommendations of the relevant Building Control Body and the pipe manufacturer.
- Where existing drains are retained, a CCTV survey will be required.

### Installation of underground drains

The depths of drains and the protection provided over them needs to be adapted to the traffic normal for the location, in accordance with the recommendations of the relevant Building Control Body and the pipe manufacturer. Requirements are as follows:

- Pipes should be laid to an even gradient (see table 1), and significant changes in gradient should be combined with an access point.
- Pipes should be laid in straight lines, but may be laid to slight curves, providing the length of drain can be effectively cleaned by the use of rods.
- Connections should be to inspection chambers or manholes, but connections to junctions are acceptable if access is provided to clear blockages. In all cases, discharge should be in the direction of flow.
- Bends should be positioned in, or adjacent to, terminal fittings, inspection chambers or manholes, and at the foot of discharge stacks. Bends should have as large a radius as practicable.
- The system should be ventilated at or near the head of each main drain to allow free passage of air throughout; the maximum length of any branch serving a single appliance being 6m, and for a group of appliances, 12m.
- Where appliances are not fitted with integral traps at the point of discharge, a trap must be provided using either a trapped gully or low back trap.

**Table 1: Recommended minimum gradient of drains**

Peak flow (litres/sec)	Pipe size (mm)	Minimum gradient	Maximum capacity (litres/sec)
<1	75	1:40	4.1
	100	1:40	9.2
>1	75	1:80	2.8
	100	1:80(1)	6.3
	150	1:150(2)	15

Notes:  
 (1) Minimum of 1 WC  
 (2) Minimum of 5 WC's

# 5. Drainage

5.5  
Below Ground -  
Foul Drainage -  
to Septic Tank



### Provision of information

A full set of design drawings and specifications shall be made available to the Warranty Provider and all other interested parties prior to the associated works starting on site. This may include:

1. Position of soil stacks.
2. Proposed drainage layouts including invert levels, gradients, pipe diameters, location of inspection chambers and rodding points.
3. Position of any septic tank or cesspool in relation to adjacent buildings.
4. Results of percolation tests where treated effluent disposal is through field drains or soakaways.
5. Where drainage fields are used, we would require:
  - Details of their layout, including length and depth.
  - Details of the trench width.
  - Site investigation report confirming the ground is suitable for a drainage field.
6. Where soakaways are used:
  - Location of the soakaway in relation to any adjacent buildings.
  - Site investigation report confirming the ground is suitable for a soakaway.
  - Soakaway design to BRE 365.

The Warranty Surveyor, at their discretion, may also request supporting information that demonstrates suitability for use of any materials or systems contained within the above.

### Below ground foul drainage system

Drainage shall be designed, constructed and installed so that:

- Foul drainage systems should be designed to meet the requirements of relevant Building Regulation requirements or BS EN 752:2017 and be installed following the guidance in BS 8000-14.
- Discharges to a suitable outfall which is:
  - For septic tanks: the ground conditions and water table movements must be suitable to allow the installation. Percolation tests will be required and the Warranty Surveyor given the opportunity to appraise.
  - Has consent in writing from the appropriate regional agency; to allow discharge to or near a watercourse or river.
 Note: Consent means a clear confirmation in writing that they will allow discharge to the designated outfall for the period of Warranty cover.
- Materials and components used for foul water drainage systems, e.g. pipes, fittings and fixing accessories, inspection chambers, septic tanks etc. should conform to appropriate European Standards or European Technical Assessments (ETAs). Where no relevant European Standard or ETA exists, British Standards or British Board of Agrément Certificates should be used.
- Pipework, fittings, inspection chambers, septic tanks etc. should be installed in accordance with manufacturer's recommendations.
- Drains and associated pipework etc. must be durable and suitable for use underground.
- The installation of drainage or pipework does not adversely affect the structural stability of the building.
- Prevent the entry of hazardous ground substances, external moisture or vermin.
- Are constructed using non-hazardous materials.
- Are safe and convenient in use.

All below ground foul drainage systems need to be designed to allow the unobstructed flow of waste water to a suitable approved outfall. To achieve this, the points below should be noted at the design and installation stages:

- Foul water drainage systems only take foul waste from a property or properties and will include waste water from sinks, toilets, showers, baths, dishwashers and washing machines. These systems discharge into septic tank. Storm water should be discharged to a separate storm water disposal system so as to avoid septic tanks treating large volumes of storm water needlessly.
- Drainage from impervious surfaces such as drives, paths and hard standings must drain to a suitable rain water drainage system.
- The drainage system, including manholes, gullies, pipe connections, etc. should be protected from damage throughout the course of the construction works.
- Drainage trench excavations should be taken down to solid ground, but when this is not possible, the drainage system should be designed to accommodate any movement and made-up with a well-compacted backfill to the required formation levels.
- Where ground movement is likely to occur, flexible drainage systems should be provided, e.g. filled sites, mining areas and sites with shrinkable clay.
- Where possible, avoid passing adjacent to tree roots. Adequate precautions should be taken where this cannot be avoided, in accordance with the recommendations of the relevant Building Control Body and the pipe manufacturer.

### Installation of underground drains

The depths of drains and the protection provided over them needs to be adapted to the traffic normal for the location, in accordance with the recommendations of the relevant Building Control Body and the pipe manufacturer. Requirements are as follows:

- Pipes should be laid to an even gradient (see table 1), and significant changes in gradient should be combined with an access point.
- Pipes should be laid in straight lines, but may be laid to slight curves, providing the length of drain can be effectively cleaned by the use of rods.
- Connections should be to inspection chambers or manholes, but connections to junctions are acceptable if access is provided to clear blockages. In all cases, discharge should be in the direction of flow.
- Bends should be positioned in, or adjacent to, terminal fittings, inspection chambers or manholes, and at the foot of discharge stacks. Bends should have as large a radius as practicable.
- The system should be ventilated at or near the head of each main drain to allow free passage of air throughout; the maximum length of any branch serving a single appliance being 6m, and for a group of appliances, 12m.
- Where appliances are not fitted with integral traps at the point of discharge, a trap must be provided using either a trapped gully or low back trap.

**Table 1: Recommended minimum gradient of drains**

Peak flow (litres/sec)	Pipe size (mm)	Minimum gradient	Maximum capacity (litres/sec)
<1	75	1:40	4.1
	100	1:40	9.2
>1	75	1:80	2.8
	100	1:80(1)	6.3
	150	1:150(2)	15
Notes: (1) Minimum of 1 WC (2) Minimum of 5 WC's			

**Septic tank systems - treatment plants**

If you are not on main line drainage then you will have either a septic tank or cesspit; ordinarily, the foul waste will run to one of the above tanks while the rain water is usually kept separate to help the action of bacteria and enzymes in the tank. The outfall from the septic tank should either run to a designed drainage field or possibly straight to a river or brook; you will often find the rain water system tapped onto the outlet of a septic tank to help dilute any effluent that may pass through the system

Any septic tank or other sewerage treatment system that is intended to have an outfall to a water course should have full consent to do so, in writing from the Environment Agency (England and Wales), NIEA (Northern Ireland) or Local Authority (Scotland). This consent should clearly allow the discharge to occur for a minimum period of 15 years and should be made available upon request.

Storm water should not discharge into the septic tank or water treatment plant and should be directed to a suitably designed soakaway or sewer.

Percolation drainage fields for treatment and outfall drainage plants should not be situated uphill of dwellings.

Where the septic tank or treatment plant discharges to a soakaway, drainage field or mound suitable percolation tests should be provided in conjunction with the drainage design. The test should be carried out with at least two trial holes. The average figure from the tests should be taken. The test should not be carried out during abnormal weather conditions such as heavy rain, severe frost or drought.

**Typical sewage treatment plan (section)**

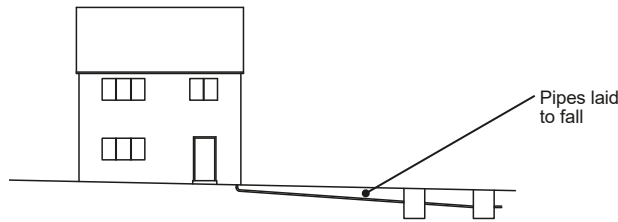

**Typical sewage treatment plant (plan)**

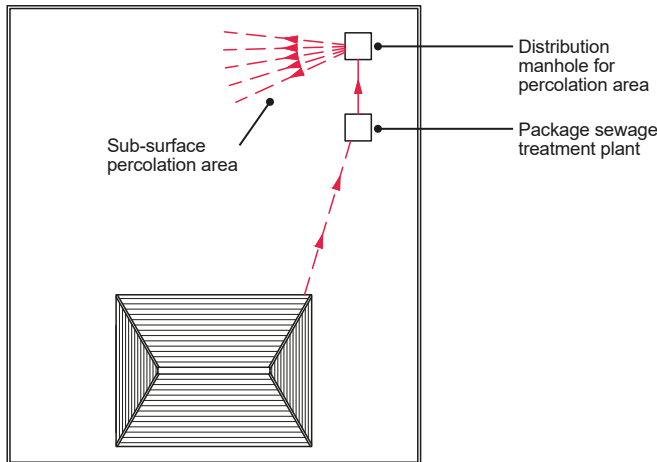

**Typical sewage treatment plant**

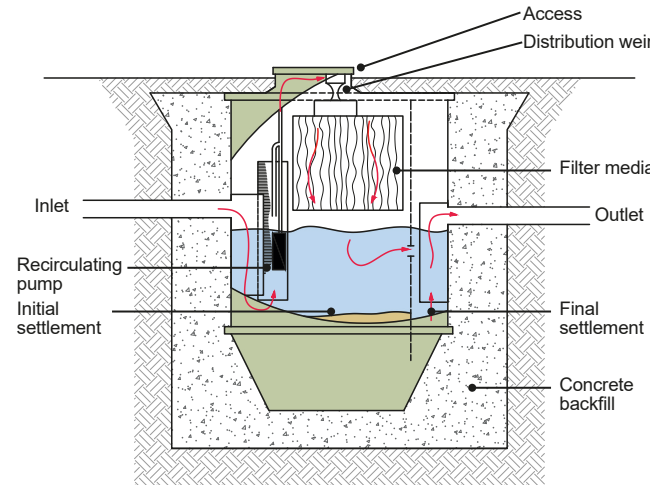

**Septic tanks**

Septic tanks should only be used in conjunction with a form of secondary treatment (e.g. drainage field, drainage mound or constructed wetland).

Septic tanks should be sited at least 7m from any habitable parts of the building and downslope. Septic tanks should have a minimum capacity of at least 2,700 litres below the level of the inlet, for up to 4 users. The size should be increased by at least 180 litres for each additional user.

Where they are to be emptied using a tanker, the septic tank should be sited within 30m of a vehicle access provided that the invert access does not exceed 3m below the level of vehicle access. Where the depth of the invert access exceed 3m this distance may need to be reduced.

Where possible tanks should not be located beneath vehicle access points unless adequate precautions are undertaken.

Septic tanks should be designed and constructed in accordance with the relevant Building Regulations.

**Drainage fields and drainage mounds**

A drainage field or mound serving a wastewater treatment plant or septic tank should be located:

- At least 10m from any watercourse or permeable drain.
- At least 50m from the point of abstraction of any ground water supply and not in any zone 1 groundwater protection zone.
- At least 15m from any building.
- Sufficiently far from any other drainage fields, drainage mounds or soakaways so that the overall soakage capacity of the ground is not exceeded.

**Drainage field**

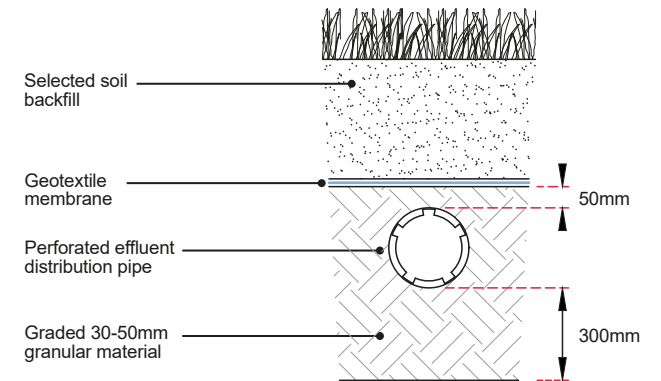
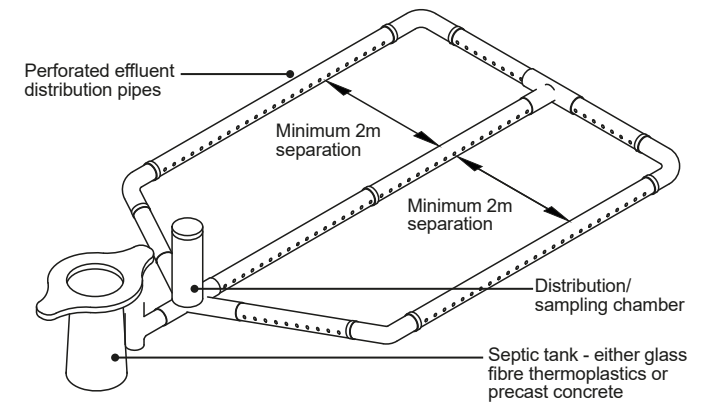

**Packaged treatment plants**

- The discharge from the waste water treatment plant should be sited at least 10m
- Away from watercourses and any other buildings.
- Treatment plants should be type tested in accordance with BS 7781.
- Where packaged treatment plants require power to operate it should be able to adequately function without power for up to 6 hours or have uninterrupted power supply.
- Packaged treatment plants should have suitable 3rd party accreditation.

# **5.**

## **Drainage**

5.6  
Below Ground -  
Storm Drainage -  
to Mains Sewer

**Provision of information**

A full set of design drawings and specifications shall be made available to the Warranty Provider and all other interested parties prior to the associated works starting on site. This may include:

1. Location of rainwater down pipes.
2. Location of slotted drainage channel systems.
3. Proposed drainage layouts including invert levels, gradients, pipe diameters, location of inspection chambers and rodding points.

The Warranty surveyor, at their discretion, may also request supporting information that demonstrates suitability for use of any materials or systems contained within the above.

**Below ground storm drainage systems**

Drainage shall be designed, constructed and installed so that:

- Storm drainage systems should be designed to meet the requirements of relevant Building Regulation requirements or BS EN 752 and be installed following the guidance in BS 8000-14.
- Discharges to a suitable outfall which is:
  - A soakaway or other infiltration system if ground conditions (1) and site location permit, or
  - A watercourse that has consent in writing from the appropriate regional agency; to allow or limit the rate of discharge. Consent from the EA, NIEA or LA means a clear confirmation in writing that they will allow discharge to the designated outfall for the period of Warranty cover, or
  - Sewer maintained by the Local sewerage undertaker, or
  - A suitable private storm drainage/sewer system (2) that leads to an adopted sewer.

Note:

- (1) For soakaways: the ground conditions and water table movements must be suitable to allow the installation to function correctly all year round. Percolation tests will be required and the Warranty Surveyor given the opportunity to appraise the results before the installation goes ahead.
- (2) Connections to private storm drainage systems will require agreement of the owners of such drain/sewer.

- Materials and components used for storm water drainage systems, e.g. pipes, fittings and fixing accessories, inspection chambers etc. should conform to appropriate European Standards or European Technical Assessments (ETAs). Where no relevant European Standard or ETA exists, British Standards or British Board of Agrément Certificates should be used.
- Pipework, fittings, inspection chambers, etc. should be installed in accordance with manufacturer’s recommendations.
- Drains and pipework etc. must be durable and suitable for use underground.
- The installation of drainage/pipework does not adversely affect the structural stability of the building.
- Prevent the entry of hazardous ground substances, external moisture or vermin.
- Are constructed using non-hazardous materials.
- Are safe and convenient in use.

All below ground storm drainage systems need to be designed to allow the unobstructed flow of storm water to a suitable approved/tested outfall. To achieve this, the points below should be noted at the design and installation stages:

- Storm water drainage systems only take storm/surface water from a property or properties and will include water from roofs, drives, paths and certain hard standing areas. These systems discharge into Local Authority sewers, soakaways or water courses. Foul drainage must not be connected to these systems.
- Impervious surfaces can drain to a permeable area within the garden providing it is free draining.
- The storm drainage system must be designed for the rainfall intensities as recommended in the applicable relevant Building Regulations. This should include allowance for where hard standing areas are also being drained into the storm water drains.
- Silt traps should be incorporated where hard standings are being drained into the storm system to avoid build-up of material in the underground drains.
- Oil interceptors should be installed on car parks, or other areas where there is likely to be leakage or spillage of oil.
- The drainage system, including manholes, gullies, pipe connections, etc. should be protected from damage throughout the course of the construction works.
- Drainage trench excavations should be taken down to solid ground, but when this is not possible, the drainage system should be designed to accommodate any movement and made-up with a well-compacted backfill to the required formation levels.
- Where ground movement is likely to occur, flexible drainage systems should be provided, e.g. filled sites, mining areas and sites with shrinkable clay.
- Where possible, avoid passing adjacent to tree roots. Adequate precautions should be taken where this cannot be avoided, in accordance with the recommendations of the relevant Building Control body and the pipe manufacturer.

**Installation of underground drains**

The depths of drains and the protection provided over them needs to be adapted to the traffic normal for the location, in accordance with the recommendations of the relevant Building Control Body and the pipe manufacturer. Requirements are as follows:

- Pipes should be laid to an even gradient (see table 1), and significant changes in gradient should be combined with an access point.
- Pipes should be laid in straight lines, but may be laid to slight curves, providing the length of drain can be effectively cleaned by the use of rods.
- Connections should be to inspection chambers or manholes, but connections to junctions are acceptable if access is provided to clear blockages. In all cases, discharge should be in the direction of flow.
- Bends should be positioned in, or adjacent to, terminal fittings, inspection chambers or manholes, and at the foot of discharge stacks. Bends should have as large a radius as practicable.

**Table 1: Minimum gradient of drains**

Pipe diameter (mm)	Minimum gradient
100	1:80
150	1:150

# **5.**

## **Drainage**

5.7  
Below Ground -  
Storm Drainage -  
to Soakaway

### Provision of information

A full set of design drawings and specifications shall be made available to the Warranty Provider and all other interested parties prior to the associated works starting on site. This may include:

1. Location of rainwater down pipes.
2. Location of slotted drainage channel systems.
3. Proposed drainage layouts including invert levels, gradients, pipe diameters, location of inspection chambers and rodding points
4. A site investigation confirming the ground is suitable for a soakaway
5. An onsite percolation test confirming the permeability of the ground
6. Details of soakaway design in accordance with BRE:365

The Warranty surveyor, at their discretion, may also request supporting information that demonstrates suitability for use of any materials or systems contained within the above.

### Below ground storm drainage systems

Drainage shall be designed, constructed and installed so that:

- Storm drainage systems should be designed to meet the requirements of relevant Building Regulation requirements or BS EN 752 and be installed following the guidance in BS 8000-14.
- Discharges to a suitable outfall which is:
  - A soakaway or other infiltration system if ground conditions and site location permit, or
  - A soakaway or other infiltration system if ground conditions and site location permit. For soakaways: the ground conditions and water table movements must be suitable to allow the installation to function correctly all year round. Percolation tests will be required and the Warranty Surveyor given the opportunity to appraise the results before the installation goes ahead.
- Materials and components used for storm water drainage systems, e.g., pipes, fittings and fixing accessories, inspection chambers etc. should conform to appropriate European Standards or European Technical Assessments (ETAs). Where no relevant European Standard or ETA exists, British Standards or British Board of Agrément Certificates should be used.
- Pipework, fittings, inspection chambers, etc. should be installed in accordance with manufacturer's recommendations.
- Drains and pipework etc. must be durable and suitable for use underground.
- The installation of drainage/pipework does not adversely affect the structural stability of the building.
- Prevent the entry of hazardous ground substances, external moisture or vermin.
- Are constructed using non-hazardous materials.
- Are safe and convenient in use.

All below ground storm drainage systems need to be designed to allow the unobstructed flow of storm water to a suitable approved/tested outfall. To achieve this, the points below should be noted at the design and installation stages:

- Storm water drainage systems only take storm/surface water from a property or properties and will include water from roofs, drives, paths and certain hard standing areas. These systems discharge into Local Authority sewers, soakaways or water courses. Foul drainage must not be connected to these systems.
- Impervious surfaces can drain to a permeable area within the garden providing it is free draining.
- The storm drainage system must be designed for the rainfall intensities as recommended in the applicable relevant Building Regulations. This should include allowance for where hard standing areas are also being drained into the storm water drains.
- Silt traps should be incorporated where hard standings are being drained into the storm system to avoid build-up of material in the underground drains.
- Oil interceptors should be installed on car parks, or other areas where there is likely to be leakage or spillage of oil.
- The drainage system, including manholes, gullies, pipe connections, etc.,

- should be protected from damage throughout the course of the construction works.
- Drainage trench excavations should be taken down to solid ground, but when this is not possible, the drainage system should be designed to accommodate any movement and made-up with a well-compacted backfill to the required formation levels.
- Where ground movement is likely to occur, flexible drainage systems should be provided, e.g. filled sites, mining areas and sites with shrinkable clay.
- Where possible, avoid passing adjacent to tree roots. Adequate precautions should be taken where this cannot be avoided, in accordance with the recommendations of the relevant Building Control Body and the pipe manufacturer.

### Layout of land drains

Drain runs on sloping sites need to be positioned perpendicular to the fall of the site. Land drains should be positioned adjacent to paths, drives and outbuildings. The pipe soffit should be positioned at least 400mm below the finished ground level, and the backfill consolidated to the same degree of compaction as the adjacent soil.

### Soakaways

Soakaways are a simple way of dispersing surface and storm water in circumstances where connection to the storm water sewer system is not feasible or unnecessary. A soakaway is basically a system that loses water rather than collects water. Soakaways are part of the Sustainable Urban Drainage Systems (SuDS) technologies that handle storm water at the source rather than leading it into the public sewer systems.

Soakaways can only be considered in permeable conditions. A suitable site must be:

- In a location lower than the area being drained.
- At least 5m away from any building (BS 8301).
- Situated so that it will not saturate the foundations of any structure.
- Situated so that the base of any soakaway/infiltration system is permanently above the water table.
- Situated far enough away from other soakaways/infiltration systems to ensure that the capacity of those other systems and the ground itself is not impaired.
- Situated so that there is no risk of contamination from pollutants.

### Sustainable urban drainage systems (SuDS)

Developments proposing to use other types of Sustainable Urban Drainage Systems (SuDS) should follow the guidance found in 'SuDS Manual' (a design manual published by CIRIA). The developer should also confirm if the Planning consent for the project imposes any additional requirements which may impact on the design of the sustainable drainage systems (SuDS). Any surface water drain, soakaway or other infiltration system (including a SuDS system) which is intended to discharge to a water course should have consent to discharge in writing from the appropriate regional agency.

### Installation of underground drains

The depths of drains and the protection provided over them needs to be adapted to the traffic normal for the location, in accordance with the recommendations of the relevant Building Control body and the pipe manufacturer. Requirements are as follows:

- Pipes should be laid to an even gradient (see table 1), and significant changes in gradient should be combined with an access point.
- Pipes should be laid in straight lines, but may be laid to slight curves, providing the length of drain can be effectively cleaned by the use of rods.
- Connections should be to inspection chambers or manholes, but connections to junctions are acceptable if access is provided to clear blockages. In all cases, discharge should be in the direction of flow.
- Bends should be positioned in, or adjacent to, terminal fittings, inspection chambers or manholes, and at the foot of discharge stacks. Bends should have as large a radius as practicable.

Table 1: Minimum gradient of drains

Pipe diameter (mm)	Minimum gradient
100	1:80
150	1:150

### Chamber-type soakaway

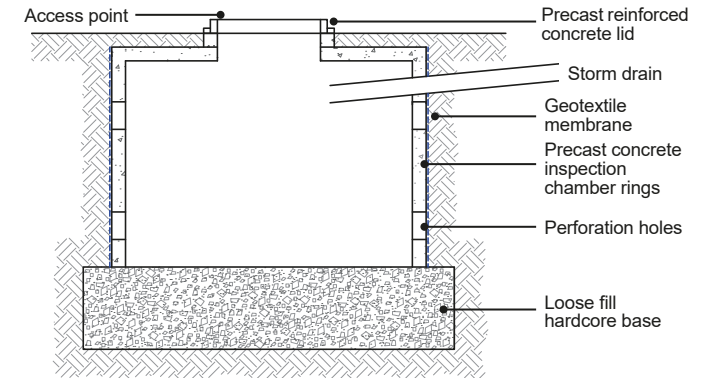

### Typical soakaway design

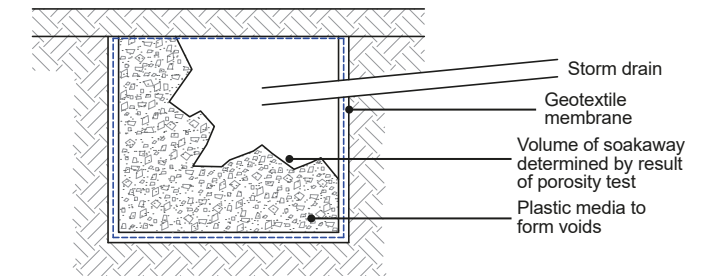

### Soakaways where chalk is prevalent

For sites where chalk is prevalent, the CIRIA C574 Engineering in Chalk 2002 publication gives the following recommendations:

Concentrated ingress of water into the chalk can initiate new dissolution features, particularly in low-density chalk, and destabilise the loose backfill of existing ones. For this reason, any soakaways should be sited well away from foundations for structures or roads, as indicated below:

- In areas where dissolution features are known to be prevalent, soakaways should be avoided if at all possible but, if unavoidable, should be sited at least 20m away from any foundations.
- Where the chalk is of low density, or its density is not known, soakaways should be sited at least 10m away from any foundations.
- For drainage systems, flexible jointed pipes should be used wherever possible; particular care should be taken for the avoidance of leaks in both water supply and drainage pipe work.
- As the chalk is a vitally important aquifer, the Environment Agency and Local Authority must be consulted when planning soakaway installations where chalk lies below the site, even where it is mantled with superficial deposits.

**T** 0800 183 1755   **E** enquiries@labcwarranty.co.uk   **labcwarranty.co.uk**



@LABC\_Warranty



LABC Warranty



LABC Warranty

MD Insurance Services Ltd. is the scheme administrator for LABC Warranty and is authorised and regulated by the Financial Conduct Authority. Registered in England No: 3642459. **TS-11A-11.00-010223**

