



TECHNICAL MANUAL

VERSION 11

4: GROUND FLOORS

4. Ground Floors

Contents

Functional Requirements

4.1 Suspended Beam and Block

4.2 Ground Supported Slab

4.3 Suspended Slab

4.4 General Requirements for Concrete Floors

4.5 Suspended Timber

Limitations of Functional Requirements

1. These Functional Requirements do not and will not apply to create any policy liability for any remedial works carried out by the contractor or otherwise, nor to any materials used in those remedial works
2. The guidance provided in this Section, is guidance that provides a suggested solution to meeting the Functional Requirements. If an alternative solution is selected, then this must still meet the Functional Requirements.

Workmanship

1. Certification is required for any specialist's works or systems completed by an approved installer.
2. All workmanship must be within the tolerance requirements set out in this Technical Manual.
3. All work is to be carried out by a technically competent person in a workmanlike manner.
4. Concreting shall not take place during cold weather periods where the working temperature is below 2°C or where ground conditions are frozen.

Materials

1. All materials should be stored, installed and protected correctly in a manner that will not cause damage or deterioration of the product.
2. All materials, products and building systems shall be appropriately tested and approved for their intended purpose.
3. All load bearing structural elements providing support to the Home will have a service life of not less than 60 years, unless specifically agreed otherwise with us. All other parts of the Home will have a lesser durability and need planned maintenance, repair or replacement during that reduced period.
4. Timber should be adequately treated or finished to resist insect attacks and be suitable for the position used within the structure. All timber treatment should be in accordance with relevant British standards and Codes of Practice.
5. Timber used in the building to provide support to the structure must be appropriately seasoned to prevent excessive shrinkage and movement.
6. All materials should be suitable for the relative exposure of the building in accordance with the relevant British Standards.
7. Reclaimed materials may only be reused with the prior agreement with the Warranty Surveyor. Independent certification and/or testing of the suitability may be required.

Design

1. Ground floors shall be designed and constructed so that they:
 - a. Provide a suitable surface for normal dwelling activities;
 - b. Are structurally sound;
 - c. Are durable and resistant to moisture passing into the internal environment of the building;
 - d. Have an adequate thermal performance;
 - e. Prevent the entry of hazardous substances from the ground into the building.
2. The design and specifications shall provide a clear indication of the design intent and demonstrate a satisfactory level of performance.
3. The following additional elements shall be supported by structural calculations designed by an Engineer:
 - a. Structural elements outside the parameters of Building Regulations.
 - b. Specialist structural works.
 - c. Reinforced concrete elements.
 - d. Precast structural elements.
 - e. Any engineered beams/posts manufactured off-site.
4. Projects consisting of Non-standard/Modern methods of construction must be supported with evidence of valid independent third party product conformity certification before an offer of Warranty is provided. These types of constructions must be declared before commencement.

4.

Ground Floors

4.1

Suspended Beam and Block

Provision of information

A full set of design drawings and specifications shall be made available to the Warranty Provider and all other interested parties prior to the associated works starting on site. This may include:

1. Manufacturer's floor layout drawings and calculations.
2. Plan details showing dimensions, levels and locations of incoming service penetrations.
3. Details indicating the depth and position of below ground services.
4. Details of junctions between DPM and DPC.
5. Ventilation provision should be detailed by the designer.
6. Details indicating the locations of all load and non-load bearing walls.
7. Manufacturer's third party certification for the proposed insulation to be used within the floor.
8. Details of underfloor heating systems where being used.
9. Third party certification for non-standard beam & block flooring.

The Warranty Surveyor, at their discretion, may also request supporting information that demonstrates suitability for use of any materials or systems contained within the above.

Influence of trees and clay

In clay soils if the foundation depth is greater than 1.5m, allowance should be made in the design for heave. This must incorporate either a clear void of a specified minimum depth under the suspended floor, or a proprietary compressible material/void former below the underside of the floor construction. Please refer to the 'Foundations – Trees and Clay' section for further guidance.

Site preparation

All topsoil and organic matter should be removed from beneath the suspended floor. The ground level should be at least the same as the external ground level unless the ground below the floor is free draining.

Alternatively, a DPM linked to the DPC can be provided.

Ground Gases

Ground floors must be designed and constructed to ensure adequate protection against ground gases emanating from the ground below.

Contaminants should be identified within the site investigation report and the recommendations provided within the report should be followed. Please refer to the 'Ground Conditions' section for further guidance.

Suitability of beam and block floors

All beam and block flooring systems must have appropriate third-party certification.

The manufacturer's details and specification for the floor must include:

- Structural calculations for the floor indicating depth and centres of the precast floor beams.
- The minimum specification of walls supporting the beam and block floor.
- Specifications for the blocks infilling between the beams, including compressive strength and thickness of the block.

All beam and block floors shall be installed ensuring that the following standards are met:

- The floor beams must be laid reasonably level and onto suitable solid and level bearings.
- Floor beams and blocks are grouted together using cement/sand slurry with a mix ratio of 1:6 respectively.
- The beam and block floor should not be used to support load-bearing walls.
- All walls should be built off an appropriate foundation, as indicated in the 'Foundations' section.
- A suitable mortar bed is required where block work between the floor beams bear onto load-bearing walls, e.g. perimeter walls.
- Holes must not be made through the floor beams and any service penetrations should pass through the holes made in the infill blocks. Any gaps around service penetrations should be filled with concrete (ST3) mix before screeding.

Where beam and block floors are to be installed to areas with higher potential point loads such as garages, additional reinforcing of the screed will be required to distribute loads effectively. This reinforcing should be of at least an 'A' mesh quality, and the screed should be thick enough to give an appropriate depth of cover.

Damp proof courses (DPC)

DPC's should be laid on a mortar bed and correctly lapped at junctions and corners. The depth of lap should be the same as the width of the DPC.

DPC's should be of a flexible material that is suitable for its intended use, and the DPC should have appropriate third-party certification.

DPC's should not bridge any cavities unless it is acting as a cavity tray. Where a cavity tray is required, please refer to the 'External Walls' section for cavity tray, weep holes, and stop end requirements.

Damp proof membranes (DPM)

A DPM should be a minimum thickness of 1200g polythene and linked to the DPC with a minimum 100mm overlap. DPM sheets should be overlapped by at least 300mm. DPM's must be carefully protected where folded up the perimeter walls, and lapped under the DPC particularly at door openings. Temporary protection should be given whilst exposed. The DPM should not be cut at the floor junction as this will prevent correct lapping with the DPC.

Other DPM's may be considered if they have appropriate third-party certification and are installed in accordance with the manufacturer's instructions.

Insulation

In all circumstances, insulation within the floor construction should be chosen to take the following into account:

- The insulation should be durable enough to withstand loadings, moisture and any ground contaminants.
- The insulation should comply with relevant Building Regulations.
- The floor insulation should be compatible with wall insulation.
- Any risk of thermal bridging is mitigated, especially at junctions with the floor and wall. The following can be considered at design stage:
 - Installing perimeter insulation to floors.
 - Linking floor and wall insulation.
 - Extending cavity wall insulation below floor slab level.

Note: A number of insulation products require an additional DPM to protect the surface of the insulation. It is important that this additional membrane is incorporated in these situations.

Resistance to ground moisture

The precast beam and block substructure floor shall be designed to prevent water ingress. There are two common methods of achieving this:

Method 1 - Damp proof membrane (DPM)

- A DPM should be provided beneath the screed or insulation; the floor void beneath the beams should be appropriately vented, ensuring that a cross flow of air between two external walls is achieved.
- The minimum area of ventilation should equate to at least 1500mm² per metre run of external wall. This roughly equates to an air brick every 3m centres for a typical PVC 225mm x 75mm air brick.
- The ventilated void must have a minimum depth of 150mm from the underside of the floor.

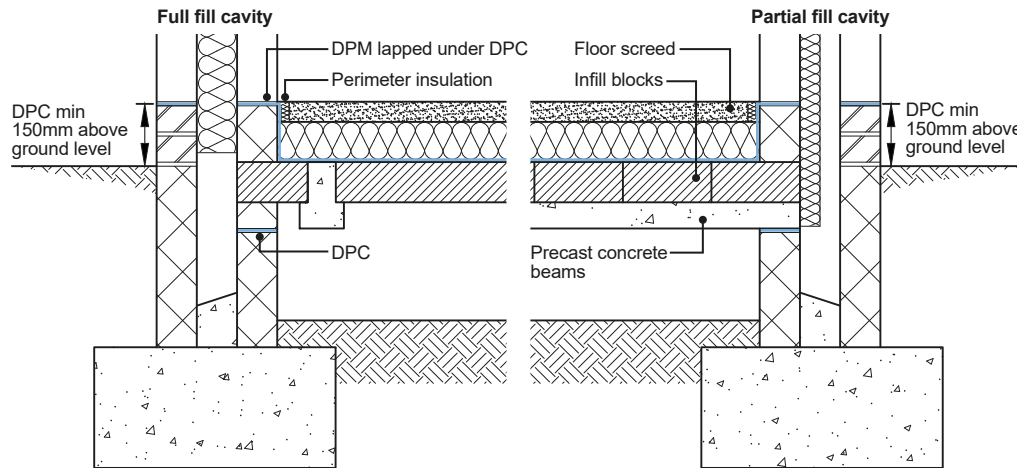

Note: Insulation must be installed to meet the manufacturers installation requirements and the relevant Building Regulations.

Method 2 - No damp proof membrane (DPM)

Where no DPM is incorporated into the precast beam and block floor, the following provisions will apply:

- The beam and block floor must be laid above the DPC.
- The floor void beneath the beams should be appropriately vented to ensure that a cross flow of air between two external walls is achieved.
- The minimum area of ventilation should equate to at least 1500mm² per metre run of external wall. This roughly equates to an air brick every 3m centres for a typical PVC 225mm x 75mm air brick.
- The ventilated void must have a minimum depth of 150mm from the underside of the floor.
- The solum level must be at the same level as the external ground level.

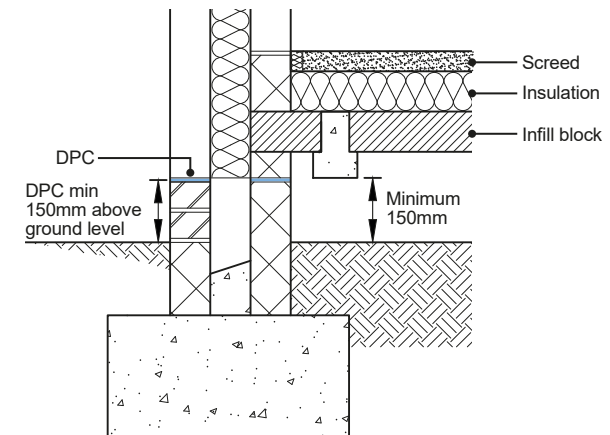

Note: Insulation must be installed to meet the manufacturers installation requirements and the relevant Building Regulations.

General notes

- Where the solum level is below the external ground line, a suitable drainage provision to avoid build up of ground water must be provided.
- If ground conditions consist of clay soils and trees that are, were, or are likely to be present, the void under must allow for heave potential in the solum.
- At party wall junctions, where required, the floor should have appropriate sound and fire resistance in accordance with the relevant Building Regulations.

4.

Ground Floors

4.2

Ground Supported Slab

Provision of information

A full set of design drawings and specifications shall be made available to the Warranty Provider and all other interested parties prior to the associated works starting on site. This may include:

1. Plan details showing dimensions, levels and locations of incoming service penetrations.
2. An Engineer's full set of structural calculations for the floor construction.
3. Details indicating the depth and position of below ground services.
4. Details of junctions between DPM and DPC.
5. Manufacturer's third party certification for the proposed insulation to be used within the floor.
6. Details of underfloor heating systems where being used.

The Warranty surveyor, at their discretion, may also request supporting information that demonstrates suitability for use of any materials or systems contained within the above.

Influence of trees and clay

Ground bearing slabs should not be used in ground conditions where heave can occur or where the foundation depth is greater than 1.5m. Under these circumstances a suspended floor construction should be used.

Site preparation

The ground beneath the floor should be stripped of all topsoil, organic matter or tree roots prior to filling and compaction.

Suitable hard core would include inert quarried material such as limestone or granite. Recycled aggregates may be used, which include crushed concrete or broken brick; however, these must be completely free of contaminants and plaster and should be delivered to site from a supplier that has a quality audit process in place.

Materials available as a result of any site demolition should not be used as hard core beneath floor slabs unless specifically agreed by the Warranty Surveyor and only then if it can be demonstrated that the material is completely free of contaminants and plaster.

Hard core should be placed and compacted in 150mm nominal layers and be fully consolidated using a mechanical compactor. A ground supported concrete floor will not be acceptable where the depth of the hard core exceeds 600mm and an alternative suspended ground floor construction must be used. Hard core material should not be saturated and should be taken to ensure that the new walls are not disturbed by compaction of the hard core.

All services placed under the floor construction must be suitably protected and sleeved where penetrating through the floor slab. DPM's must be correctly sealed around these penetrations.

Ground gases

Ground floors must be designed and constructed to ensure adequate protection against ground gases emanating from the ground below.

Contaminants should be identified within the site investigation report and the recommendations provided within the report should be followed. Please refer to the 'Ground Conditions' section for further guidance.

Concreting of floors

Prior to concreting, any water or debris that may have collected on top of the DPM should be removed. Concrete should ideally be ready mixed and be of at least GEN1 (see 'Appendix C - Materials, Products, and Building Systems: Concrete - Cold weather working and minimum specification' for further information). Expansion joints should be provided in accordance with 'Appendix C - Materials, Products, and Building Systems' section.

The floor must be laid reasonably level.

Damp proof courses (DPC)

DPC's should be laid on a mortar bed and correctly lapped at junctions and corners. The depth of lap should be the same as the width of the DPC.

DPC's should be of a flexible material that is suitable for its intended use, and the DPC should have appropriate third-party certification.

DPC's should not bridge any cavities unless it is acting as a cavity tray. Where a cavity tray is required, please refer to the 'External Walls' section for cavity tray, weep holes, and stop end requirements.

Damp proof membranes (DPM)

A DPM should be provided beneath all ground-supported slabs. DPM's should be a minimum thickness of 1200g polythene and linked to the DPC with a minimum 100mm overlap. DPM sheets should be overlapped by at least 300mm. DPM's must be carefully protected where folded up the perimeter walls, and lapped under the DPC particularly at door openings. Temporary protection should be given whilst exposed. The DPM should not be cut at the floor junction as this will prevent correct lapping with the DPC.

Membranes should be laid either onto a concrete slab or onto a minimum 5mm sand blinding (if laid below a floor slab).

Other DPM's may be considered if they have appropriate third-party certification and are installed in accordance with the manufacturer's instructions.

Insulation

Insulation that is to be provided to ground floors can be placed either above or below the concrete slab. In all circumstances, insulation within the floor construction should be chosen to take the following into account:

- The insulation should be durable enough to withstand loadings, moisture and any ground contaminants.
- The insulation should comply with relevant Building Regulations.
- The floor insulation should be compatible with wall insulation.
- Any risk of thermal bridging is mitigated, especially at junctions with the floor and wall. The following can be considered at design stage:
 - Installing perimeter insulation to floors.
 - Linking floor and wall insulation.
 - Extending cavity wall insulation below floor slab level.

Note: A number of insulation products require an additional DPM to protect the surface of the insulation. It is important that this additional membrane is incorporated in these situations.

Ground bearing floor - insulation below slab

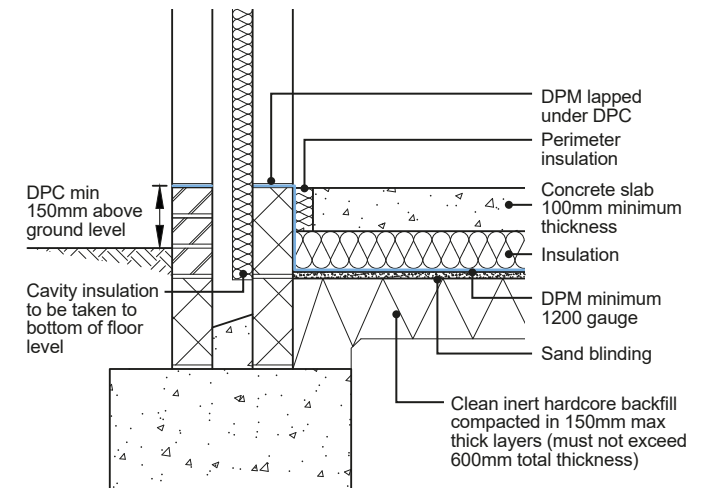

Ground bearing floor - insulation above slab

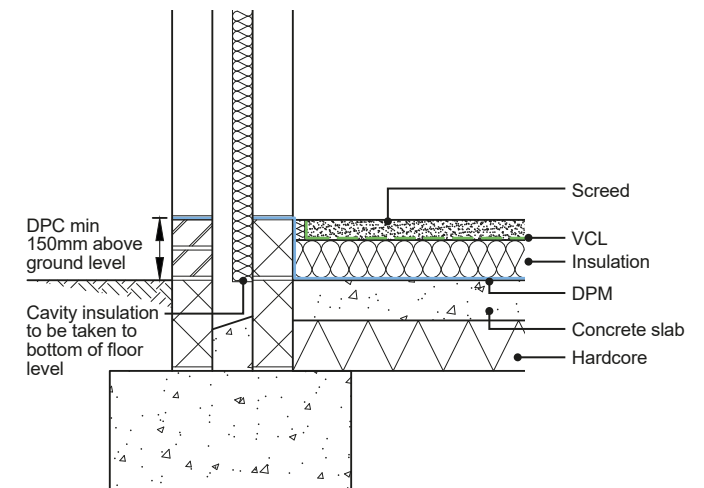

General notes

- If ground conditions consist of clay soils and trees that are, were, or are likely to be present, a suspended floor construction should be used.
- Where required the floor should have appropriate sound and fire resistance in accordance with the relevant Building Regulations.
- Insulation must be installed to meet the manufacturers installation requirements and relevant Building Regulations.

4.

Ground Floors

4.3 Suspended Slab

Provision of information

A full set of design drawings and specifications shall be made available to the Warranty Provider and all other interested parties prior to the associated works starting on site. This may include:

1. An Engineer's full set of structural calculations for the floor construction.
2. Plan details showing dimensions, levels and locations of incoming service penetrations.
3. Details indicating the depth and position of below ground services.
4. Details of junctions between DPM and DPC.
5. Details indicating the locations of all load and non-load bearing walls.
6. Ventilation provision should be detailed by the designer.
7. Manufacturer's third party certification for the proposed insulation to be used within the floor.
8. Details of underfloor heating systems where being used.
9. Detailed on how the slab is to be reinforced.
10. Details of the concrete mix to be used.

The Warranty Surveyor, at their discretion, may also request supporting information that demonstrates suitability for use of any materials or systems contained within the above.

Influence of trees and clay

In clay soils if the foundation depth is greater than 1.5m, allowance should be made in the design for heave. This must incorporate either a clear minimum void of a specified depth under the suspended floor or a proprietary compressible material / void former below the underside of the floor construction. Further guidance can be found in the 'Foundations - Trees and Clay' section.

Site preparation

The material below the proposed floor slab should be compacted sufficiently to support the slab during the pouring and curing stages. Any backfill material should not contain any organic matter, or contaminants that could react with the concrete or be susceptible to swelling, such as colliery waste.

Ground gases

Ground floors must be designed and constructed to ensure adequate protection against ground gases emanating from the ground below.

Contaminants should be identified within the site investigation report and the recommendations provided within the report should be followed. Please refer to the 'Ground Conditions' section for further guidance.

Suspended reinforced in-situ slabs

Structural design

A cast in-situ suspended concrete slab should be designed by an Engineer.

The structural design should include the following information:

- Adequacy of walls that support the concrete slab (intermediate and perimeter walls).
- Suitable thickness, correct durability of concrete and correct provision of reinforcing.
- Provision of anti-crack reinforcing to the perimeter of floors.

Concreting of floors

Prior to concreting, any water or debris that may have collected on top of the DPM should be removed.

The depth of concrete will vary depending upon the load conditions and the span of the floor. The overall reinforced concrete slab design should be designed by an Engineer.

- The reinforced concrete should have a minimum strength of RC35 and be ready mixed and delivered on-site.
- Site mixing of concrete is not considered suitable for concrete suspended floors.
- The poured concrete should be lightly vibrated and well tamped to ensure that no voids are left within the floor slab.

The floor slab should be appropriately shuttered around its perimeter to enable a cavity to be formed between it and the external wall. The shuttering can be expanded polystyrene (which is removed once the concrete has set) or a proprietary shuttering system.

The suspended floor construction must be laid reasonably level and onto suitable solid and level bearings.

Damp proof courses (DPC)

DPC's should be of a flexible material that is suitable for its intended use and the DPC should have appropriate third-party certification. Blue brick or slates will not be accepted as a DPC.

DPC's should be laid on a mortar bed and correctly lapped at junctions and corners. The depth of lap should be the same as the width of the DPC.

DPC's should not bridge any cavities unless it is acting as a cavity tray. Where a cavity tray is required (e.g. over a telescopic floor vent) please refer to the 'External Walls' guidance for cavity tray, weep holes, and stop end requirements.

Damp proof membranes (DPM)

DPM's should be provided beneath all reinforced suspended slab. DPM's should be a minimum thickness of 1200g polythene and linked to the DPC with a minimum 100mm overlap. DPM sheets should be overlapped by at least 300mm. DPM's must be carefully protected where folded up the perimeter walls, and lapped under the DPC particularly at door openings. Temporary protection should be given whilst exposed. The DPM should not be cut at the floor junction as this will prevent correct lapping with the DPC.

Other DPM may be considered if they have appropriate third-party certification and are installed in accordance with the manufacturer's instructions.

Insulation

Insulation that is to be provided to ground floor should be placed above the concrete slab. Insulation should be installed in accordance with the manufacturer's instructions and be durable enough to withstand floor loadings and moisture. A number of insulation products require an additional DPM to protect the surface of the insulation.

In all circumstances, insulation within the floor construction should be chosen to take the following into account:

- The insulation should be durable enough to withstand loadings, moisture and any ground contaminants.
- The insulation should comply with relevant Building Regulations.
- The floor insulation should be compatible with wall insulation.
- Any risk of thermal bridging is mitigated, especially at junctions with the floor and wall. The following can be considered at design stage:
 - Installing perimeter insulation to floors.
 - Linking floor and wall insulation.
 - Extending cavity wall insulation below floor slab level.

Typical suspended slab

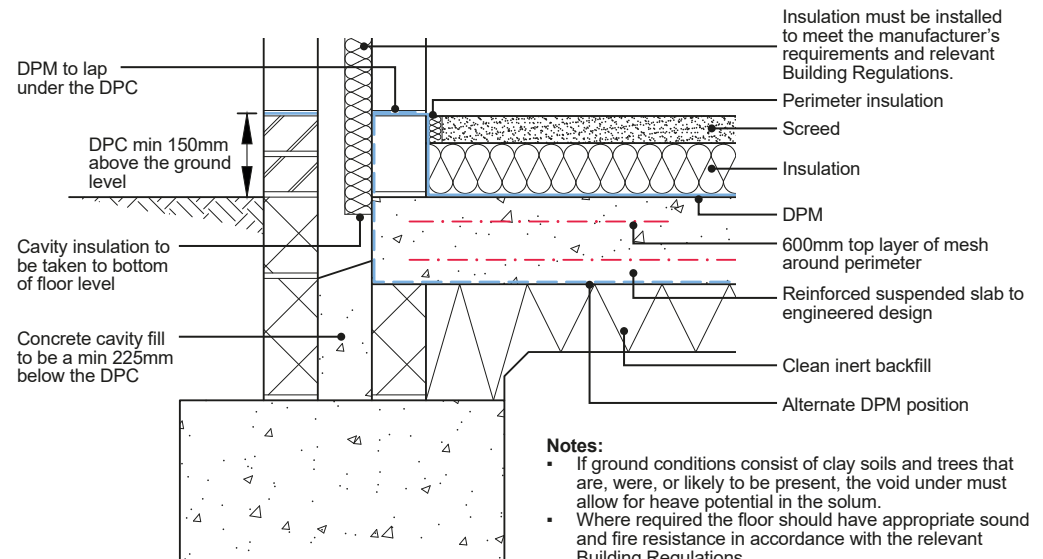

Reinforcing cover

The main reinforcing bars must have a minimum concrete cover of 40mm. Suitable spacers should be provided to support the reinforcing prior to concreting.

Cast in-situ suspended concrete - floor reinforcing cover and support

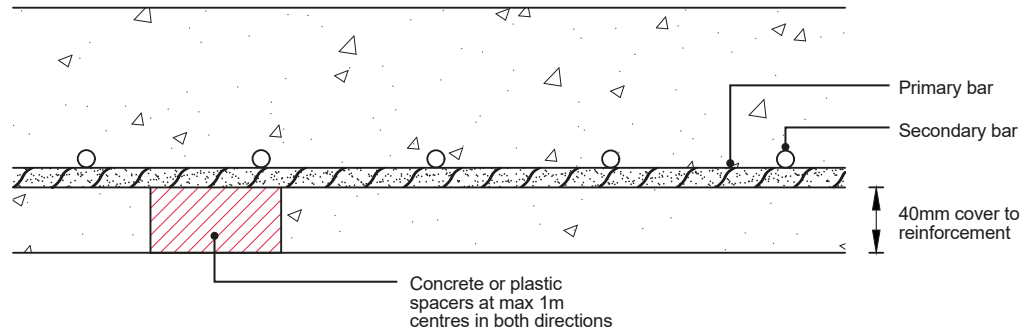

Standard of fabric reinforcing

Reinforcing fabric should be free from loose rust, oil, grease, mud and any other contaminants that may affect the durability of the concrete. Reinforcing fabric should be of a 'B' mesh grade. This can be identified by the size of the primary and secondary bars. Primary bars are spaced at 100mm centres and secondary bars are placed at 200mm centres, as indicated in Table 1.

Table 1: Standard 'B' mesh reinforcing details

BS Reference	Primary Bar			Secondary Bar		
	Size (mm)	Spacing of bars (mm)	Area (mm ² /m)	Size (mm)	Spacing of bars (mm)	Area (mm ² /m)
B1131	12	100	1131	8	200	252
B785	10	100	785	8	200	252
B503	8	100	503	8	200	252
B385	7	100	385	7	200	193
B283	6	100	283	7	200	193
B196	5	100	196	7	200	193

Table 2: Minimum laps for reinforcing

Minimum laps for main reinforcing bars in fabric mesh (1)	
Fabric Type	Minimum lap (mm)
B1131	500
B785	400
B503	350
B385	300
B283	250
B196	200

Note: (1) A minimum lap of 300mm is required for secondary reinforcing bars.

Lapping of reinforcing

It is accepted that reinforcing can consist of a number of sheets that can be joined together as identified in Table 2. The depth of cover may need to be increased to maintain minimum cover depending on the thickness of mesh reinforcing. All loose reinforcement that acts as part of the reinforcing layers must be adequately tied together.

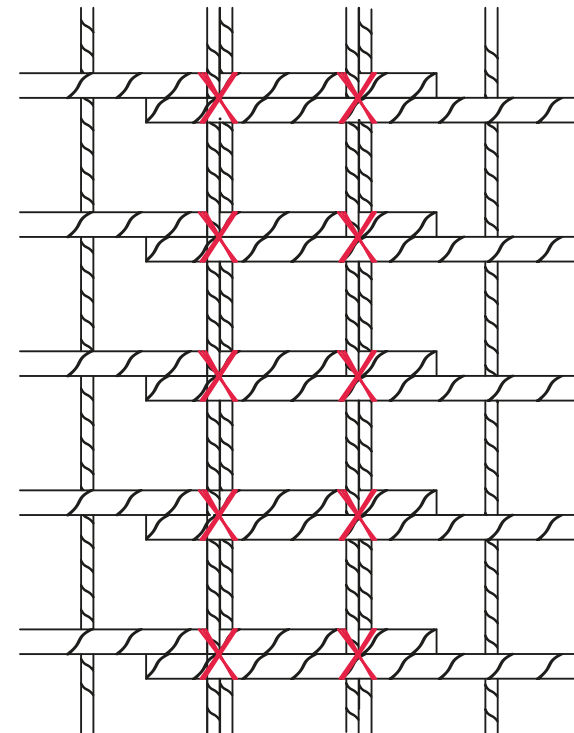

4.

Ground Floors

4.4

General Requirements for Concrete Floors

Provision of information

A full set of design drawings and specifications shall be made available to the Warranty Provider and all other interested parties prior to the associated works starting on site. This may include:

1. Details of proposed floor screeds including thickness and mix.
2. Details of substrates to which the screeds will be laid upon.
3. Details of proposed curing times and environmental constraints.

The Warranty Surveyor, at their discretion, may also request supporting information that demonstrates suitability for use of any materials or systems contained within the above.

Stepped party walls up to 150mm

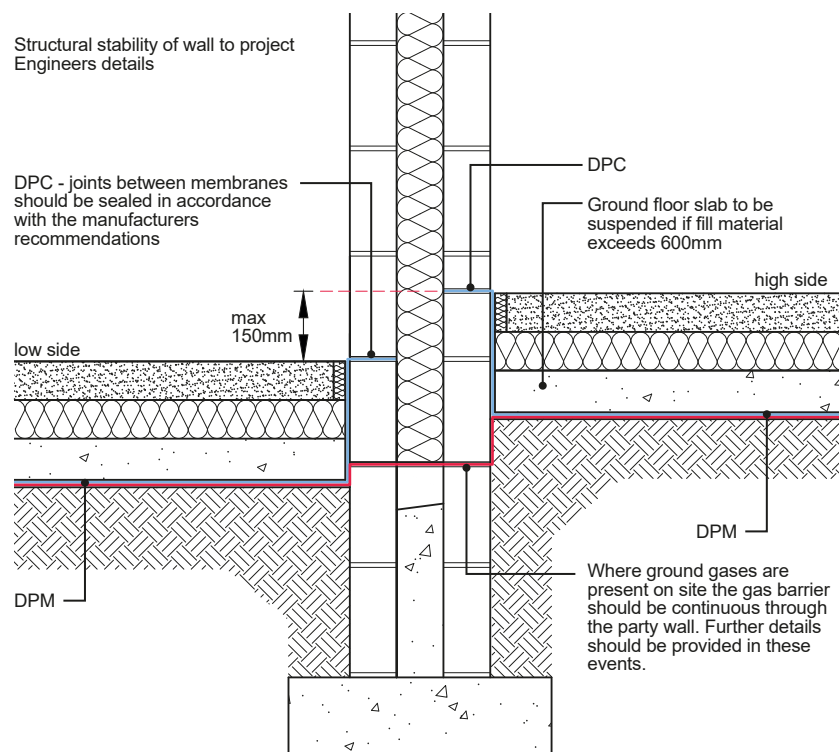

Where a difference between finished floor levels of adjacent ground slabs internally or at a party wall does not exceed 150mm and the external ground levels of the perimeter external walls are a minimum of 150mm below the DPC in all locations, a waterproofing specialist solution is not required, however on sites where ground gases are present it is important that the continuity of the gas barrier is maintained through a party wall.

Stepped party walls up to 600mm

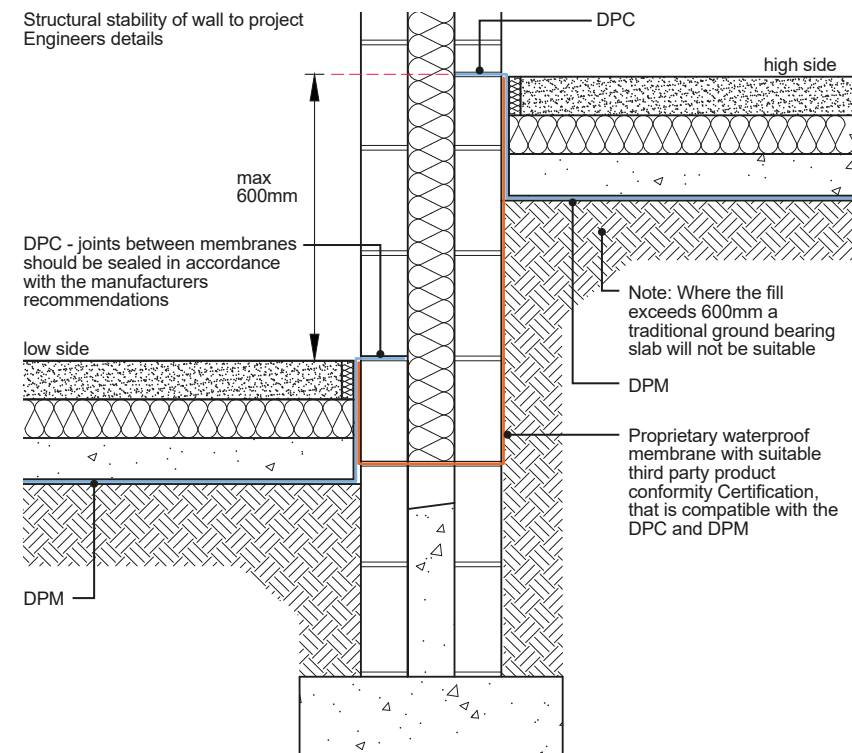

Where the difference between finished floor levels of adjacent ground slabs between party walls does not exceed 600mm and the external ground levels of the perimeter external walls are known to be a minimum of 150mm below DPC in all locations, a self-adhesive waterproof membrane may be used on the primed and prepared substrate. The product however must hold a suitable third party product conformity certification, that demonstrates suitability and resistance to hydrostatic pressure, and that is suitable for the prevailing site conditions to ensure that the grade environment specified can be maintained for the design life.

To protect the waterproofing membrane a suitable drainage protection board should be used and the graded backfill should be specified to provide free drainage of water to a level below the lower slab.

Stepped party walls exceeding 600mm

Where the difference between finished floor levels exceeds 600mm a waterproofing solution from a suitably qualified Waterproofing Design Specialist should be provided.

Detailing of the waterproofing should also be considered at the junction of the party wall changes in levels and the flanking walls as additional waterproofing maybe deemed necessary at this location.

A single line of defence could be acceptable where a fully bonded type 'A' membrane is specified on a primed and prepared substrate. Alternatively a combined and maintainable system will need to be considered by the Waterproofing Specialist

The coordinated design team must take overall responsibility for the design liability including the waterproofing specialist.

For further information relating to "Who is appropriately qualified as a Waterproofing Design Specialist" please refer to the 'Basements' section.

Screeds

Traditional floor screeds consist of sand and cement. If the ratios and properties of these screeds are not correctly controlled; cracking, peeling or collapse of the screed will occur (due to being too strong/weak).

Proprietary screeds typically are pre-blended to achieve greater consistency and strength and more suitable over larger areas. As such where the floor area exceeds 50m² only a proprietary screed installed by the screed manufacturers trained installers will be accepted.

Screeds should be fit for purpose, have a suitable finish and be of an appropriate thickness and provide a reasonably level surface.

Curing

Screeds should be cured naturally and should not be covered for at least three weeks.

Background surfaces

Background surfaces where screeds are being supported should meet the following requirements:

- **Bond**
Background surfaces for bonded screeds should provide an adequate mechanical key. If necessary, cement grouting or a bonding agent should be specified to provide adequate adhesion. Where bonded screeds are used, mechanical means of preparing the concrete should be used to create an adequate bond between the substrate and the screed.
- **Moisture protection**
The floor design should ensure that moisture from the ground does not enter the dwelling.
- **Adequate support**
Substrate structures must be adequately constructed to provide adequate support to the screed. (Note: Timber floor constructions are not suitable to support screeded finishes).
- **Screed mix**
Cement and sand screeds should have a mix ratio of between 1:3 and 1:4½.

Proprietary additives should have been assessed and have third-party certification.

The minimum thicknesses of screeds are as follows:

Screed thickness requirements

Surface	Minimum thickness at any point (mm)
Laid monolithically with base	12
Laid and bonded to a set and hardened base	20
Laid on a separating membrane (e.g. 1000g polyethylene)	50
Laid on resilient slabs or quilts (screed reinforced with galvanised wire mesh)	65

Where service pipes are bedded in the screed, the screed should be deep enough to provide at least 25mm of screed cover over service pipes, insulation and reinforcing.

Maximum areas of screed

Screeds should be laid room by room. Unreinforced screeds should have a maximum area of 40m². Expansion joints should be provided and consistent with joints in the floor slab below.

Finishing of screeds

Screed should provide an even surface as appropriate, as defined in the 'Tolerance' section. Concrete floor slabs may be suitably finished to serve directly as a wearing surface without the need for an additional topping, in accordance with the recommendations of BS 8204. If required, surface sealers or hardeners should only be used in accordance with the manufacturer's instructions.

Anhydrite (liquid) screeds

If an anhydrite screed is used, it must be sealed before the application of any cement based floor finish adhesive is proposed. Anhydrite screeds can be difficult to identify once laid, if the screed type cannot be identified the screed should be fully sealed as a precaution to prevent the possibility of the floor finish adhesive de-bonding from the screed.

The floor screed should be fully dry before the sealant is applied. The screed drying time will depend on the thickness and type of screed.

A decoupling membrane is also recommended as this can reduce the stress on the fixed floor finish layer.

Insulation

Insulation below screeds should have enough compressive strength to support the screed. DPM's should be installed in the correct positions, as indicated by the insulation manufacturer's instructions. Sound insulation should be installed in accordance with the manufacturer's instructions.

Constructing screeds over all substrates:

- Substrates must be level with no pockets or high spots to ensure the thickness of the screed remains even.
- Where screeds are laid over insulation; the insulation must be tightly butted together and level.
- Screeds must be correctly mixed.
- Screeds must not be walked on during the drying period.
- Screeds must not be constructed during cold periods (below 5 degrees).
- Movement joints will be required across door thresholds.
- Movement joints are required if bay sizes exceed 40m² with a maximum of 8m on any one side.
- Movement joints are also required where joints exist or a change of span occurs e.g. beam and block floors.
- The screed must be ready to accept any floor finishes (see guidance below for over insulated substrates).

Drying times

- With cementitious levelling screeds, one day should be allowed for each millimetre of thickness for the first 50 mm, followed by an increasing time for each millimetre above this thickness (BS 8204).
- Polymer modified screeds: strictly follow the manufacturer's specifications and recommendations.
- The developer should keep an accurate record of the screed drying times elapsed before any fixed floor finish is constructed on top is laid and the Warranty surveyor may ask for this information.

Note: The moisture contents of levelling screeds onto which particular floorings are to be laid and methods for measuring moisture content are given in BS 5325, BS 8201, BS 8203 and BS 8425.

Building services

Where building services pass through the screed e.g. underfloor heating, allowance should be made for thermal movement between the screed and the service (so that service pipes can resist chemical attack from the screed).

Additional steps where constructing screeds over concrete substrates

Where a concrete slab is insulated from below and a finishing screed is required to the top surface:

- The concrete substrate slab must be of the correct thickness and not less than 100mm thick.
- Concrete substrate must be adequately dried out and not wet. See drying time guidance.
- Surfaces of hardened in situ concrete bases for bonded screeds should be roughened (Scrabbled) and cleaned to remove laitance and to expose cleanly, but not loosen, the coarse aggregate particles.
- Brushing to remove laitance from a fresh concrete base is inadequate preparation before laying a bonded screed and is not recommended.
- Remove all loose debris, dirt and dust by appropriate means, preferably with vacuum equipment.
- Carry out the preparation of the surface with as little delay as is practicable before the screed is laid so as to reduce the risk of contamination.
- The surface of the prepared slab must be reasonably level to avoid deviations in thickness's of the screed.

Constructing screeds over insulated substrates with under floor heating (UFH) system

1. Provision and construction of movement joints

Movement joints should be provided in the floor screed / fixed floor finish where floor heating is provided in the following places:

- Between independently controlled heating zones.
- Between heated and unheated areas of screed.
- Additional joints should be considered in areas of high thermal gain e.g. large conservatories or glass atria.

Bay joints should be formed using rigid joint formers where possible, which can be placed during the preparation phase and will remain in place during operation. The joint former should be 5mm lower than the finished screed depth to allow a smooth transition in height between bays.

- All joints in the screed should extend through to any subsequent bonded floor covering.
- Joint positions should be specified prior to the installation of the screed and full consultation between all parties including the main contractor, underfloor heating installer, finished flooring installer and the screed installer should take place to determine appropriate locations.
- Movement joints should be carried through the subfloor to the floor finish and all applied layers terminated either side of the joint.
- The joint should be filled with a suitable flexible filler and a proprietary cover strip applied to cover the joint. Grout must not be used.
- Movement joints should not be bridged by any resilient, textile or other adhered floor finish.
- Movement joint covers may be flush, surface mounted or bedded in mortar and metal, metal with a rubber insert or PVC (see typical detail below).

Typical movement joint covers

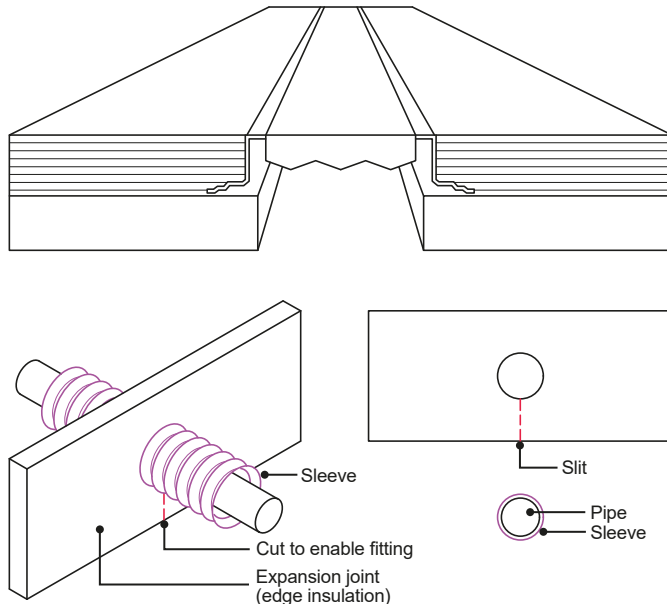

2. Provision of edge strip perimeter expansion joint

When incorporating under floor heating (UFH):

- Screeds should be isolated at all edges, abutments and columns to allow for movement due to thermal loadings.
- The floor screed and finished floor manufacturers guidance to be followed particularly when incorporating under-floor heating to determine the minimum thickness of edge strip required to allow for expansion. Typically, between 6-15mm may be required.
- The joint can be concealed by the skirting.
- These joints must be left empty, or else filled with a compressible material.
- Movement joints must not be filled with grout.

3. Screed drying time

- The drying time allowed must be calculated for the proposed depth of screed, taking account of the environmental conditions present e.g. temperature and humidity. Where polymer modified type screeds are being used the manufacturer's requirements must be strictly followed for the actual depth of screed. Surface finishes placed on a screed too early will fail.
- Drying times for polymer modified screeds could potentially be different to cementitious screeds.
- All subcontractors involved with the screed and floor finishes (including installation of underfloor heating systems) must follow the installation requirements and not deviate or change materials.
- The screed should not be walked on until fully cured.

4. UFH testing and commissioning

- Ensure there are no joints in the heating system loops.
- UFH systems should be commissioned before floor finishes are applied. This will add to the total time before any floor finish can be applied. Note: If floor finishes are installed prior to the UFH being turned on and commissioned, any residual moisture in the floor is driven to the surface of the screed and can potentially cause delamination of the floor finish.
- Pressure testing of the system does not constitute commissioning of the system. The heat source has to be in place and operating in order to deliver the correct temperatures.
- The UFH system must be commissioned in accordance with the manufacturer's recommendations by their approved installers. A commissioning certificate will be required.

5. Moisture testing of the screed where floor finishes are proposed:

- Moisture testing should be carried out after the commissioning of the UFH system but before any floor finishes are laid.
- Where UFH is not installed, moisture testing of the screed should still be carried out before floor finishes are installed.
- Moisture testing is carried out using a suitable approved method such as a flooring hygrometer or carbide bomb test. Due to the potential inaccuracies of using hygrometers at high humidity levels, a direct measurement should be used such as Carbide Bomb or oven dried sample.
- The base is deemed to be sufficiently dry when the relative humidity, as measured by a surface mounted flooring hygrometer/probe is 75% RH or less. For the use of a flooring hygrometer, reference should be made to Dampness testing in BS 5325, BS 8203, BS 8425 and BS 8201.
- If underfloor heating is present in the base, the heating must be switched off 96 hours prior to any hygrometer test being carried out.
- The hygrometer must be allowed to remain in position until full equilibrium has been established. This is generally considered to be 72 hours but could be longer over thick sections and considerably longer on power floated concrete.

6. Screed preparation for finishes

- The top surface of screeds may require to be scored, sanded or keyed in preparation to accept the primer and floor finish.
- Sanding, keying etc. of the screed surface allows the penetration of primers. It also provides a "key" for the adhesive to grip onto.
- The surface must then be cleared of dirt and debris prior to primers being applied.
- Any primers and adhesives must not be applied until the screed has fully hardened and dried out. Drying times vary depending on the type of screed.
- Surfaces to receive fixed floor finishes should be rigid, dimensionally stable, flat with no dips and rises, sound, clean and free from laitance, paints, salts, grease, dust and any contamination which may prevent adhesion.

7. Adhering to the manufacturers' process during the installation of the flooring finish.

All the relevant manufacturers recommendations should be followed which will identify timelines to adhere i.e:

- Removing the laitance by sanding to provide a key for the primer and/or adhesive.
- Commissioning the underfloor heating before installing the fixed floor finish.
- Allowing the UFH system to cool down for at least 48 hours before installing the fixed floor finish.
- Moisture testing to confirm the dryness of the screed before installing the fixed floor finish.
- Ensuring the time from screed completion to installing the fixed floor finish commencement is calculated and adhered to.
- Ensure the fixing of the finished floor finish has stabilized before walking on. Some finishes require typically 12 -24 hours dependent on environmental conditions.
- Ensure the UFH system is not turned on for at least 48 hours after any adhered floor finish is completed.
- If an anhydrite screed is used, it must be sealed before the application of a cement based floor finish adhesive if proposed in conjunction with a finished floor surface covering.

8. Exceeding the maximum 27°C floor temperature

The underfloor heating system must be correctly commissioned to ensure temperature fluctuations are avoided and potential damage to the floor finishes.

BS 8203 Code of Practice for the Installation of Resilient Floor Coverings states: When used with many flooring materials underfloor heating can cause problems if the temperature at the interface between the subfloor and flooring exceeds 27°C, or is subject to rapid fluctuations in temperature.

Where a resilient floor covering is proposed: 'the temperature should never exceed the agreed maximum of 27°C at the underside of the floor covering (the adhesive line).

Note: UFH designers may refer to this as the 'interface' temperature.

Please Note: BS EN 1264 - 2 refers to a max 29°C however for Warranty purposes a maximum 27°C is to be followed.

9. End user information

End users must be aware of how to use an UFH system, as these need to be operated differently than other heating systems both for in use and to avoid damage to screeds and finishes.

4.

Ground Floors

4.5

Suspended Timber

Provision of information

A full set of design drawings and specifications shall be made available to the Warranty Provider and all other interested parties prior to the associated works starting on site. This may include:

1. An Engineer's full set of structural calculations for the floor construction.
2. Plan details showing dimensions, levels and locations of incoming service penetrations.
3. Details indicating the depth and position of below ground services.
4. Details of proposed floor joists to be used including floor joist layouts.
5. Details of junctions between DPM and DPC.
6. Details indicating the locations of all load and non-load bearing walls.
7. Manufacturer's third party certification for the proposed insulation to be used within the floor.
8. Details of underfloor heating systems where being used.

The Warranty Surveyor, at their discretion, may also request supporting information that demonstrates suitability for use of any materials or systems contained within the above.

Influence of trees and clay

In clay soils if the foundation depth is greater than 1.5m, allowance should be made in the design for heave. This must incorporate either a clear minimum void of a specified depth under the suspended floor. Further guidance can be found in the 'Foundations - Trees and Clay' section.

Ground gases

Ground floors must be designed and constructed to ensure adequate protection against ground gases emanating from the ground below.

Contaminants should be identified within the site investigation report and the recommendations provided within the report should be followed. Please refer to the 'Ground Conditions' section for further guidance.

Durability of suspended timber floors

To prevent the decay of timber joists, the suspended timber floor should be constructed in such a way that:

- All joists and wall plates are above the DPC level.
- A minimum void of 150mm is provided between the joists and oversite.
- Air bricks are provided to give adequate cross ventilation to the floor void.
- Joists have adequate bearings and do not protrude into the cavity.

Suspended timber ground floor running parallel to wall

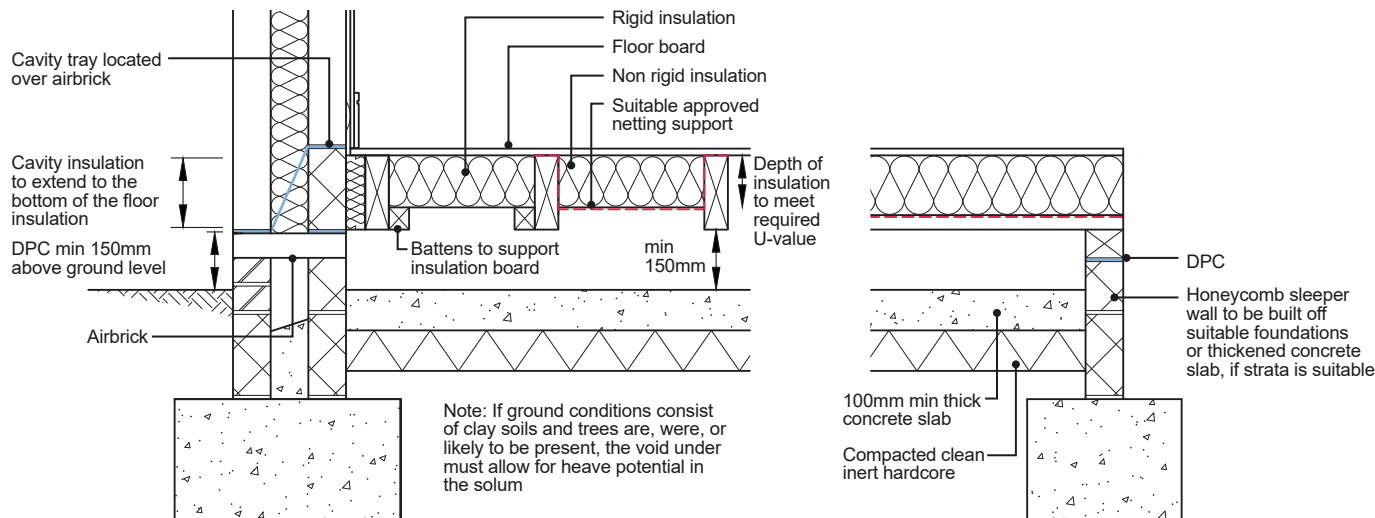

Floor joists

All floor joists must be of a suitable durability and strength grade (minimum C16), be of the correct size and stress grade and be laid at the correct specified centres as indicated on plans and specifications. The joists should have consistent dimensions and be securely nailed to timber wall plates.

The floor joists must be laid reasonably level and onto suitable solid and level bearings.

Please refer to the 'Tolerances' section for guidance on levelness and deflection limits of floor joists. There may be an instance where a joist might be designed to meet permissible deflections within a relevant British Standard; however, our tolerance requirements will take precedence.

Joists at the junction with the external and party walls should be supported on suitable joist hangers and be adequately strutted at mid-span.

Floor joists can be supported internally by sleeper walls. Sleeper walls should be built off an adequate foundation if the ground is of suitable bearing strata, or can be built of a reinforced thickened slab where designed by an Engineer.

Sub floor ventilation requirements

To prevent decaying floor joists, sub-floor ventilation must be provided and give a free cross flow of air. External air bricks should be provided in two opposing walls and must meet the provision detailed in Table 1.

Table 1: Minimum cross ventilation provision

Floor area of building (m ²)	Minimum ventilation provision (mm ²)
40	20,000
60	30,000
80	40,000
100	50,000
120	60,000
140	70,000
160	80,000

Air bricks should be evenly spaced along the two opposing walls that meet the ventilation provision. Typical ventilation areas for various types of air bricks are identified in Table 2.

Table 2: Typical air brick net ventilation area capabilities (ventilation rates vary between different manufacturers)

Air brick type	Dimensions WxH (mm)	Net area (mm ²)
Clay air brick square holes	225x75	1400
	225x150	4300
	225x225	6400
Clay air brick louvred	225x150	2000
	225x225	6400
PVC air brick	225x75	4645

The cross flow of air must not be interrupted by internal walls or low hanging insulation. All internal walls must have air bricks to allow the free flow of air, or be built using a honeycomb technique.

Suspended timber ground floor bearing onto an external wall

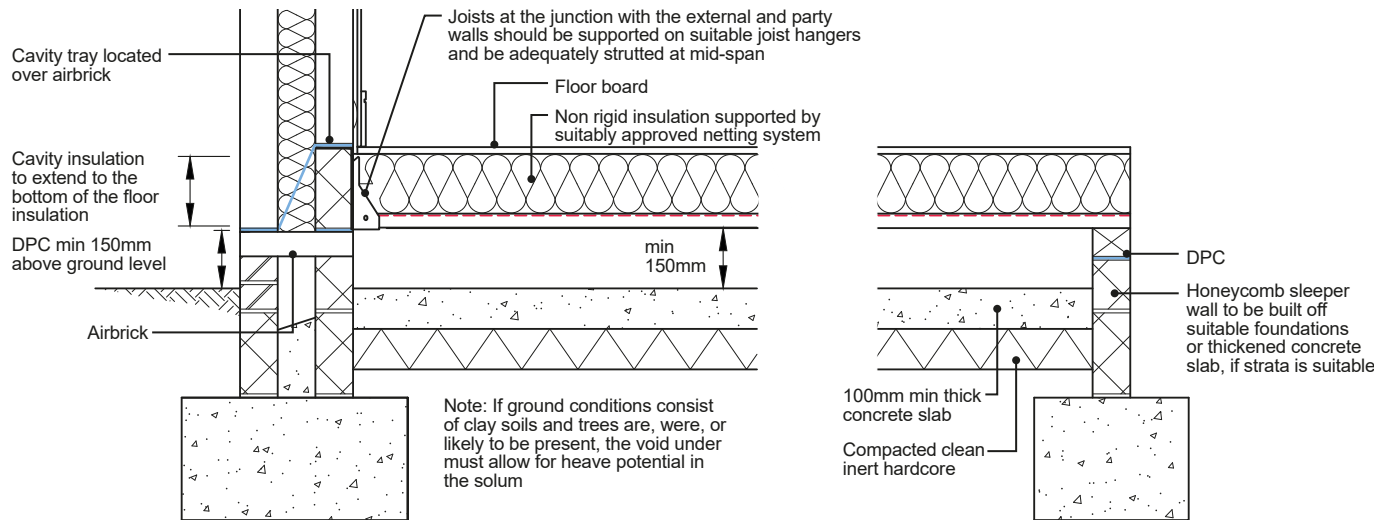

Damp proof courses (DPC)

Damp Proof Courses should be of a flexible material that is suitable for its intended use and the DPC should have appropriate third-part certification. Blue brick or slates will not be accepted as a DPC.

DPC should be laid on a mortar bed and correctly lapped at junctions and corners. The depth of lap should be the same as the width of the DPC.

DPC should not bridge any cavities unless it is acting as a cavity tray. Where a cavity tray is required (e.g. over a telescopic floor vent) please refer to the 'External Walls' section for cavity tray, weep holes, and stop end requirements.

Stepped floors

For lower ground floors on sloping sites and semi basements timber suspended ground floors are not recommended.

Concrete oversite

A suitable oversite should be provided at least 150mm below the timber suspended floor.

The oversite should be either:

- 100mm thick concrete over-site (GEN 3) on well-compacted hard core, or;
- 50mm thick concrete over-site on a 1200g DPM laid on 25mm sand blinding and well-compacted hard core.

For sites that are susceptible to gas migrations, the oversite should incorporate gas protection measures designed by a suitable specialist.

Where the joists are supported on joist hangers

It is necessary to ensure that:

- The hanger is bedded directly on the masonry and there is no gap between the hanger back-plate and the face of the masonry.
- At least 450mm of masonry is provided above the hanger or as per manufacturer's requirements.
- Hangers are spaced at centres of floor joists included in the design.
- The hanger is suitable for the loadings and masonry strength.

Do not:

- Apply load while the mortar is still green and has not gained sufficient strength.
- Use brick courses in block walls under joist hangers as the thermal insulation of the wall may be reduced unless similar units to the blocks are used.

Typical restraint type joist hanger

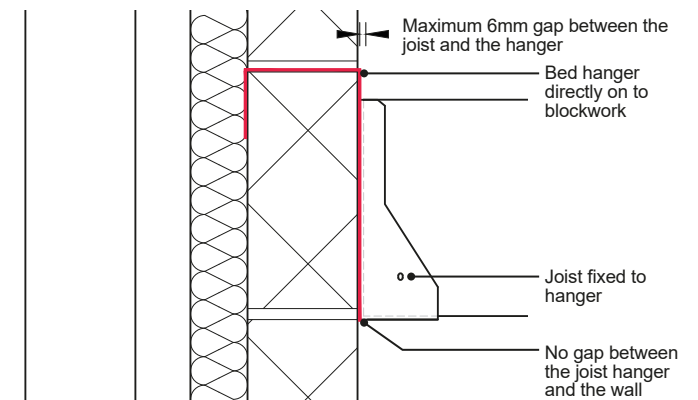

Strutting of joists with a span between 2.5m and 4.5m

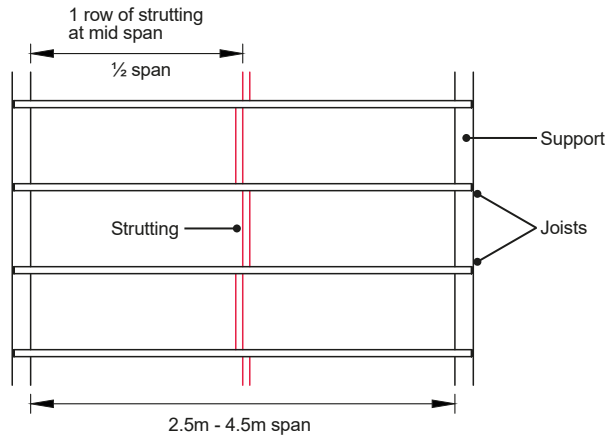

Where the span of a floor joist is more than 2.5m, strutting is necessary. This should be provided either by timber bridging or strutting in accordance with Figure 3 of BS 8103-3 or by a proprietary system.

Strutting of joists with a span over 4.5m

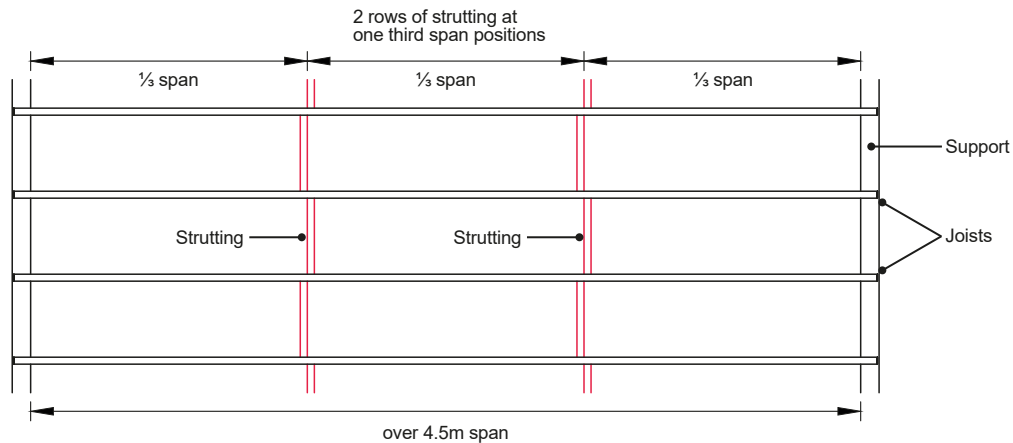

Where the span of a floor joist or flat roof joist is more than 4.5m, two rows of strutting at $\frac{1}{3}$ the span position will be necessary.

Strutting or bridging of solid timber floor joists

Where the span of a floor joist is more than 2.5m, strutting is necessary. This should be provided either by timber bridging or strutting in accordance with Figure 3 of BS 8103-3 or by a proprietary system.

Timber strutting can be in the form of solid bridging of at least 38mm basic thickness and with a depth equal to at least three-quarters of the depth of the joists; or it can consist of herringbone strutting with members of at least 38mm by 38mm basic size. Herringbone strutting should not be used where the distance between the joists is more than approximately three times the depth of the joists.

Deflection of floors

For timber floors (intermediate floors), designers and Engineers must observe our tolerance requirements for levelness of floors and deflection limits. Please refer to the 'Tolerances' section for further guidance.

There may be an instance where a joist might be designed to meet permissible deflections within a relevant British Standard; however, our tolerance requirements will take precedence.

Typical trimming detail (plan)

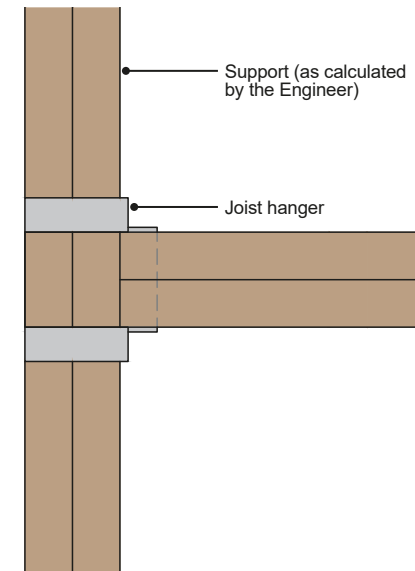

Joists should have a minimum end bearing of 90mm, unless joist hangers are used, where a 35mm bearing is acceptable (subject to the manufacturer's details).

Double joists should be bolted together at 600mm centres using minimum 10mm diameter bolts with large washers that will prevent the bolt head and nut from penetrating the joist. It is recommended that the bolting of double joists is along the centre line of joists. Suitably sized trimmer joists shall be provided around floor openings.

Trimmed openings may be needed around chimneys. Solid trimmed joists may be supported using either joist hangers or a structurally designed connection; timber trimmers around openings should consist of at least two members and be designed by an Engineer.

Sizing of floor joists

For advice on 'sizing of certain timber members in floors for dwellings', the Designer should refer to the following sources:

- Span tables for solid timber members in floors, ceilings and roofs (excluding trussed rafter roofs) for dwellings. Published by TRADA. Note: Reference should be made to the version of the TRADA document current at the time of construction of the floor/timber or roof.
- BS 8103-3, Structure design of low rise buildings, Code of Practice for timber floors and roofs for dwellings.
- BS EN 1995-1, Eurocode 5 design of timber structures. General: Common rules and rules for buildings.

To prevent the distortion of finishes, joists should be stopped from twisting over supports and provision provided to accommodate up to 12mm of drying shrinkage in floor joists supported by steel beams.

It is essential that joists are not overloaded during construction. Joints in joists should only be in place over a load-bearing support, or the joint be designed by an Engineer.

Joists should be restrained at supports using tightly fitted strutting.

Permissible areas for the notching of joists

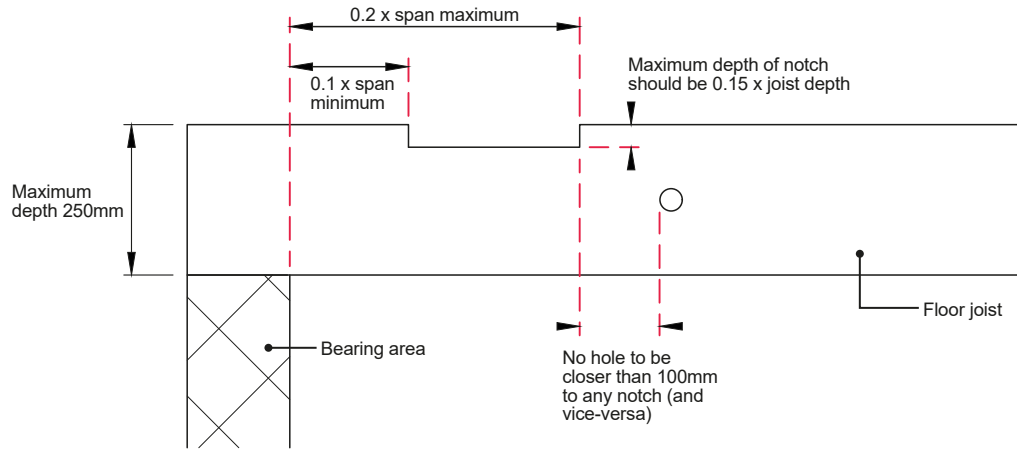

Permissible areas for the drilling of joists

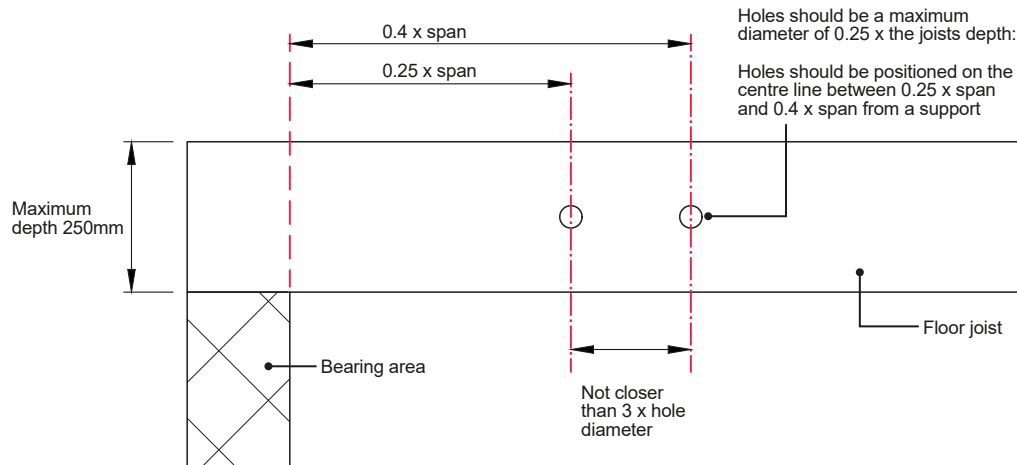

Notching and drilling in solid timber joists

Requirements for notching and drilling of solid timber joists (further guidance can be found in BS 8103, TRADA span tables, BS EN 1996 and PD 6693-1).

This guidance is for joists up to 250mm deep, notching and drilling for joists exceeding this depth should be designed by the Engineer.

Notches: Notches should be made in between 0.1 and 0.2x span. Notches should be no deeper than 0.15x depth of the joists in this area e.g. for a 250mm deep joist, the maximum notch depth should not exceed 35mm.

Holes: Holes should be drilled on the centre line of the joist. Holes should be between 0.25 and 0.4 x the span. Holes should be a maximum diameter of 0.25x the joists depth and kept apart by at least 3x the diameter. The maximum hole diameter should not exceed 65mm.

Note: Notches and holes should be a minimum of 100mm apart.

The table below gives an indication of the areas in a joist which are suitable for notching and drilling.

Typical permissible zones for notching and drilling of solid timber joists

Span (m)	Notches to be taken out only within these zones (m)		Holes only to be drilled within these zones (m)	
1.5	0.15	0.3	0.375	0.6
2	0.2	0.4	0.5	0.8
2.5	0.25	0.5	0.625	1
3.0	0.3	0.6	0.75	1.2
3.5	0.35	0.7	0.875	1.4
4	0.4	0.8	1	1.6
4.5	0.45	0.9	1.125	1.8
5	0.5	1	1.25	2

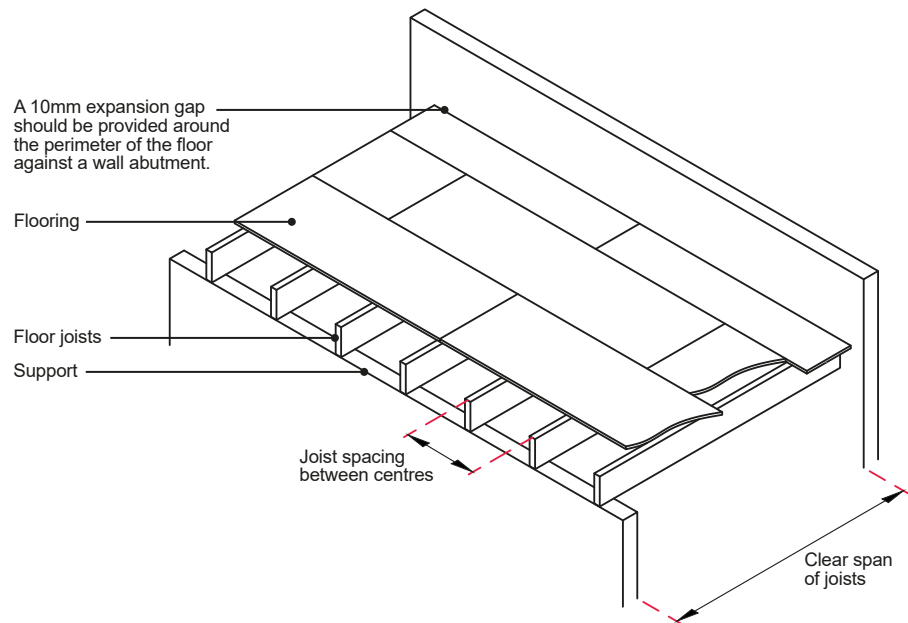
Floor joists arrangement**Insulation**

Suitable provision for insulation should be provided to meet the relevant local Building Regulations.

The insulation should be installed in accordance with the manufacturer's instructions, be suitable for the intended use and adequately supported between the floor joists.

Structural floor boarding

Suitable floor boards and decking include tongue and grooved softwood flooring, with a maximum moisture content at the time of fixing of between 6 -19% in accordance with BS 8103 - 3 (see table A1 in Annex A of the standard which gives a range of moisture content for softwood flooring, dependent on the intensity of the heating to be provided in the building e.g. where under floor heating is provided the maximum moisture content of the floor must be limited to 6 -8%, whereas in an unheated building the maximum moisture content of the floor is 15 - 19%). All boards must be double nailed or secret nailed to each joist using nails that are at least three times the depth of the board. The boards must have a minimum thickness, as indicated in the table below.

Softwood floor boarding: Minimum thickness and centres of support

Finished board thickness (mm)	Maximum centres of joist (mm)	Typical nail fixings (mm)
15	Max 450	45mm lost head nail
18	Max 600	60mm lost head nail

Particle boarding

Acceptable particle boards consist of Oriented Strand Board (OSB) or chipboard. Chipboard should be tongue and grooved and all joints glued. The boards should be laid so that the shortest length is laid parallel to the span. OSB boards should be type 3 or 4 to BS EN 300, and should be laid with the major axis at right angles to the joists (the major axis is indicated on the OSB board by a series of arrows).

Particle boards should be either screwed or nailed to the joists at 250mm centres. Nails should be annular ring shanks that are at least three times the depth of the board.

A 10mm expansion gap should be provided around the perimeter of the floor against a wall abutment.

Particle floor boarding: Minimum thickness and centres of support

Thickness (mm) (chipboard)	Thickness (mm) (OSB)	Maximum span (mm)	Typical nail fixing (mm)
18 and 19	15	450	60mm annular ring shank
22	18 and 19	600	65mm annular ring shank

Floor coverings should be fixed in accordance with BS8103 - 3.

Fire resistance

Where required the floor should have appropriate fire resistance in accordance with the relevant Building Regulations.

Sound insulation and air tightness

Due to the construction methods, it is more likely to be difficult to demonstrate satisfactory levels of air tightness and sound insulation for suspended timber ground floors. In ensuring that a reasonable level of air tightness and sound resistance is achieved, the following provisions should be incorporated:

- All joists to be supported off proprietary joist hangers at the junction with party walls and external perimeter walls.
- Floor boarding to be sealed against the wall using a sealant or proprietary tape.
- Internal floors shall where necessary, have adequate resistance to the transmission of sound transmission to meet the requirements of the relevant Building Regulations.
- The resilient layers where required should be fitted as per manufacturers instructions.
- The resilient layer and subsequent floor makeup should be suitable to support the design loads, any point loads or additional loading may have special requirements.

Floor finishes

For guidance on floor finishes onto the floor boarding, please refer to 'Appendix A - Finishes'.

T 0800 183 1755 **E** enquiries@labcwarranty.co.uk **labcwarranty.co.uk**



@LABC_Warranty



LABC Warranty



LABC Warranty

MD Insurance Services Ltd. is the scheme administrator for LABC Warranty and is authorised and regulated by the Financial Conduct Authority. Registered in England No: 3642459. **TS-11A-11.00-010223**

