



TECHNICAL MANUAL

VERSION 11

APPENDIX C

C.

Appendix C

Contents

Functional Requirements

C.1 Materials, Products, and Building Systems

C.2 Suitability of Products and Systems

Limitations of Functional Requirements

1. These Functional Requirements do not and will not apply to create any policy liability for any remedial works carried out by the contractor or otherwise, nor to any materials used in those remedial works
2. The guidance provided in this Section is guidance that provides a suggested solution to meeting the Functional Requirements. If an alternative solution is selected, then this must still meet the Functional Requirements.

Workmanship

1. All workmanship must be within the tolerance requirements set out in this Technical Manual.
2. All work is to be carried out by a technically competent person in a workmanlike manner.
3. Concreting shall not take place during cold weather periods where the working temperature is below 2°C or where ground conditions are frozen.

Materials

1. All materials should be stored, installed and protected correctly in a manner that will not cause damage or deterioration of the product.
2. All materials, products and building systems shall be appropriately tested and approved for their intended purpose.
3. All load bearing structural elements providing support to the Home will have a service life of not less than 60 years, unless specifically agreed otherwise with us. All other parts of the Home will have a lesser durability and need planned maintenance, repair or replacement during that reduced period.
4. Whilst there is and can be no Policy responsibility and/or liability for any roof covering, window/ door or 'Decorative external cladding' (i.e. Cladding which is decorative only and the substrate wall provides the main weather proof barrier) to achieve a performance service life of 60 years or less, such elements shall be designed and constructed so they have an intended service life of not less than where stipulated within this Manual.
5. Timber should be adequately treated or finished to resist insect attacks and be suitable for the position used within the structure. All timber treatment should be in accordance with relevant British standards and Codes of Practice.
6. Timber used in the building to provide support to the structure must be appropriately seasoned to prevent excessive shrinkage and movement.
7. All materials should be suitable for the relative exposure of the building in accordance with the relevant British Standards.
8. Reclaimed materials may only be reused with the prior agreement with the Warranty Surveyor. Independent certification and/or testing of the suitability may be required.

Design

1. All products must be independently proven and/ or have a third party product approval certification by recognised UKAS or equivalent product conformity body to verify suitable for the intended use.
2. All MMC systems must be designed and built using certified materials, have Quality management systems in place for the manufacture of the system and have been accepted by our Warranty Innovations Department prior to an offer of Warranty is issued.
3. The design and specifications shall provide a clear indication of the design intent and demonstrate a satisfactory level of performance.
4. The following additional elements shall be supported by structural calculations designed by an Engineer:
 - a. Structural elements outside the parameters of Building Regulations.
 - b. Specialist structural works.
 - c. Reinforced concrete elements.
 - d. Precast structural elements.
 - e. Any engineered beams/posts manufactured off-site.
5. Damp proofing works should prevent any external moisture passing into the internal environment of the building.
6. Projects consisting of Non-standard/Modern methods of construction must be supported with evidence of valid independent third party product conformity certification before an offer of Warranty is provided. These types of constructions must be declared before commencement.

C.

Appendix C

C.1

**Materials, Products, and
Building Systems**

Timber

Storage

Timber should be stored correctly to ensure it does not deteriorate. It should be kept dry and covered in cold conditions to prevent surface freezing, and should be kept off the ground and spaced to allow air to move around freely. Timber should be kept flat to prevent warping or twisting.

Storage of timber on site

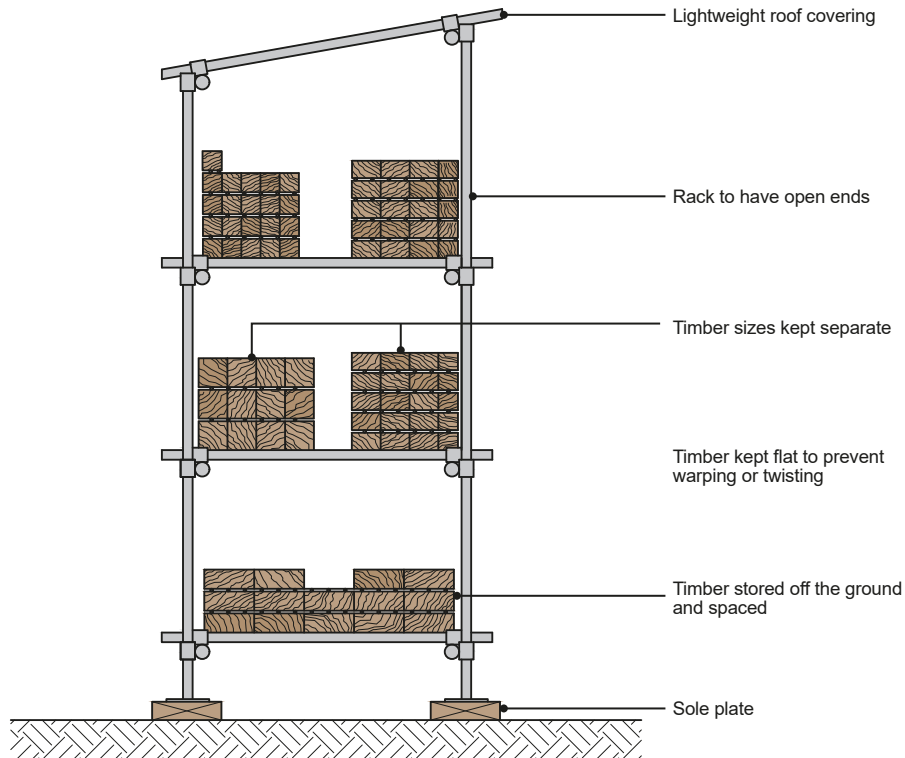

Timber treatment

Timber and joinery used in the construction shall either have adequate natural durability or, where preservative treated against fungal decay and insect attack, the timber preservative treatment should be in accordance with BS 8417 which provides information to establish the appropriate type of treatment according to the particular element and conditions of use. Tables 1 to 3 of BS 8417 must be referred to to identify 'Use classes', 'Service Factor code' and durability class of wood for the desired service life.

It is important that any pre-treated timber be re-treated if it is cut to expose untreated end grain. The treatment should be coloured so it can be proven that the end grain has been treated.

Timber durability

Timber should be appropriately treated to resist fungal decay and insect attacks. Some timber species have a natural ability to resist attack. Please refer to BS 8417 to determine the need for preservative treatment depending on the 'use class' of the timber component.

Timber grading

Timber should be of the appropriate strength classification in order to meet its design intention. For timber that is to be used for structural purposes e.g. floor joists, rafters and ceiling joists, the minimum strength classification should be C16.

Site storage of roof trusses

The delivery of trussed rafters should be planned so as to minimise the period of storage necessary on-site. When delivered the trusses should, at all times, be kept clear of the ground and vegetation and be supported by level bearers sited under or adjacent to the points of support assumed by the design.

To prevent any distortion, there is a need to ensure that the trusses are stored in a vertical position, as in 'vertical storage of trusses' below.

Horizontal storage is sometimes possible, as in 'Horizontal storage of trusses' below. In both cases, stacks of trusses should be covered with a weather proof cover, whilst maintaining adequate ventilation to prevent the occurrence of condensation. Trusses should be checked visually upon arrival on the site for damage occurring during transportation, and again before site use for damage occurring during storage. Trusses with a moisture content exceeding 20% should not be installed.

Vertical storage of trusses

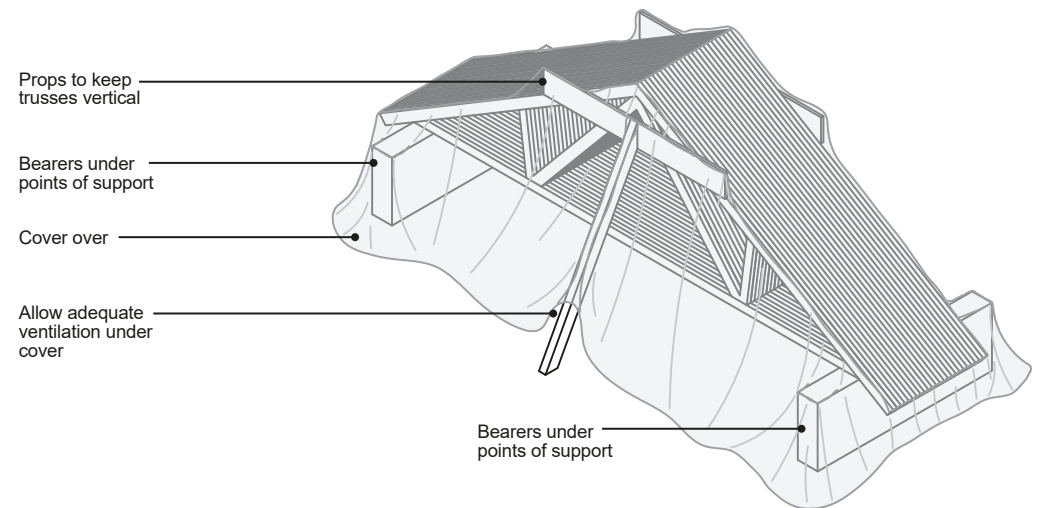

Horizontal storage of trusses

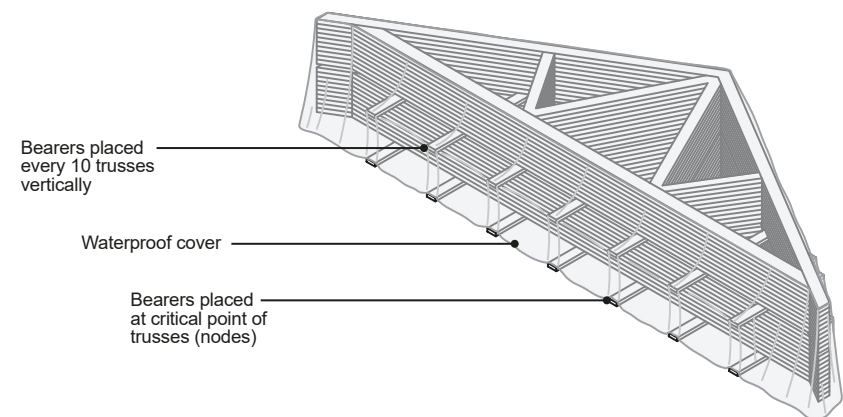

Green and air dried/seasoned oak

For the purposes of this section there are three types of oak we are referring to:

- Green Oak- Recently felled oak with a moisture content typically between 60%-80%.
- Air Dried (seasoned) Oak- Naturally stored oak with a natural seasoning process moisture content up to 30%.
- Certified Kiln Dried Oak- Processed seasoned timber with a moisture content of 12% or less.

Green Oak, air dried/seasoned oak is not acceptable for including in the external wall construction, frame, window/door construction, internal wall, or roof constructions, regardless of whether it forms part of the waterproof envelope or not, AND will not be acceptable for Warranty cover except where described below.

Green Oak or air dried oak will not be acceptable for projects requiring Warranty cover in the following situations:

- A structural element/component, either internally or externally of the property to be constructed, regardless of whether it forms part of the waterproof envelope or not.
- Windows and doors.

Air dried oak may only be acceptable in the following location:

- External cladding finish materials, subject to moisture content at the time of installation (max.16%) and a suitable second line of weather proof envelope defence provided between the cladding to protect the structural substrate and internal linings.

Certified kiln dried Oak is not acceptable for use:

- As an external 'structural' element/component of the property to be constructed, regardless of whether it forms part of the waterproof envelope or not.

Certified kiln dried Oak with a certified maximum moisture content of 12% may only be acceptable for:

- Parts of the internal structure where any movement of the oak will not affect the waterproof envelope e.g. floor beams, floor joists, roof trusses and purlins; providing the Engineer proves that any shrinkage / twisting in the oak will be catered for and be isolated from the waterproof envelope.
- Windows and doors, see guidance in the 'External Windows and Doors - Timber' section for manufacturing criteria/testing.

Please note: independent cladding/decorative cladding (i.e. Mock Tudor Cladding) which is not built into the wall should have a certified moisture content of 16% +/- 2%.

Natural durability recommendations for timber components (based on natural durability against fungi given in BS EN 350-2)

Component	Use Class (table 1 BS 8417)	Minimum durability class of wood for which heartwood can be used without treatment		Examples of service situations
		Desired service life =		
		15 years	60 years	
Internal joinery	1	5	5	Internal joinery and timbers in upper/ intermediate floors not built into solid walls
Roof timbers (dry)	1	5	5	Wood in pitched roofs except tiling battens and valley gutter members
Roof timbers (dry) (Longhorn beetle area)	1	3	3	As above
Roof timbers (risk of wetting)	2	4	2	Tiling battens, Wood in pitched roofs with high condensation risk, flat roof timbers, ground floor joists
External walls/ground floor joists	2	4	2	Frame timbers in timber frame houses, ground floor joists
Sole plates above DPC	2	3	2	Sole plates
External Joinery (non-load-bearing coated) and cladding (coated)	3 coated	4	2	Coated cladding, soffits, fascias, windows and doors, valley gutter timbers
Fence rails, deck boards and joists, external joinery (non load-bearing uncoated) and cladding uncoated	3 uncoated	3	1	Uncoated cladding, decking timber that are not in contact with the ground
Deck posts	4	2	1	
Poles	4	2	1	
Sleepers	4	2	1	

Above table is adapted from BSI Standards Publication BS8417:2011+A1:2014 Preservation of wood – Code of practice, Tables 1 & 3

Preservative treatment of roof timbers is normally unnecessary, except where specifically required under relevant standards and Codes of Practice, and in the following circumstances:

- Roof timbers should be preservative treated where the insulation and ceiling line follow the roof pitch.
- Trussed rafter construction which is cut back at eaves or where the rafter 'feet' are trimmed to sit into the external walls. Preservative treatment will be required to the cut ends.
- The Approved Document of Regulation 7 of the Building Regulations for England requires that in certain geographical areas, all softwood roof timbers should be treated against attack by the House Longhorn Beetle.

The areas at risk are:

- The District of Bracknell Forest.
- The Borough of Elmbridge.
- The Borough of Guildford (other than the area of the former Borough of Guildford).
- The District of Hart (other than the area of the former Urban District of Fleet).
- The District of Runnymede.
- The Borough of Spelthorne.
- The Borough of Surrey Heath.
- In the Borough of Rushmoor, the area of the former district of Farnborough.
- The District of Waverley (other than the parishes of Godalming and Haslemere).
- In the Royal Borough of Windsor and Maidenhead, the parishes of Old Windsor, Sunningdale and Sunninghill.
- The Borough of Woking.

The timber should be impregnated with a preservative suitable for use in 'Use Class 1' in pitched roofs (Class 2 if in pitched roofs with high condensation risk) and 'Use Class 2 flat roofs', in accordance with BS 8417, for a 60 year anticipated service life. Cut ends must be liberally brushed or dipped with an end-grain preservative.

It is strongly recommended that, where punched metal fasteners are proposed to roof trusses, only micro-emulsion or organic solvent preservatives should be used for timber treatment, to limit the possibility of corrosion of the fasteners and so as not to adversely affect glued joints.

Metal fixings

Metal components should be austenitic stainless steel, sherardized or galvanized where they are to be fixed or used adjacent to treated timber.

Standards referred to

- BS EN 1912 Structural timber-strength classes - Assignment of visual grade and species.
- BS EN 1995-1-1 Eurocode Design of timber structures.
- BS 8417 Preservative of wood - Code of Practice.
- BS EN 335 Durability of wood and wood based products.

Concrete

Cold weather working

To meet the Functional Requirements, the minimum working temperature should not fall below 2°C. It is important that during cold weather periods, regular temperature readings should be taken. Thermometers should be placed away from direct sunlight, preferably in a shaded area. When assessing the temperature, it is also important to consider wind chill and weather exposure, and make the necessary allowances for sites that have a higher level of exposure.

Ready mixed concrete

It is a requirement of BS 8500 and BS EN 206-1 that the temperature of fresh concrete shall not be below 5°C at the time of delivery. Measures should also be put in place to ensure immature concrete is prevented from freezing before sufficient strength has been achieved.

Site mixed concrete

Site mixing is acceptable at low temperatures, provided:

- The minimum temperature is no less than 2°C.
- The concrete is appropriately protected during curing.
- Ground conditions are not frozen.

Concreting of foundations and oversite

Concrete should not be poured if the ground is frozen as frozen ground can change in stability and volume during thawing, and therefore may cause damage to the recently poured concrete.

During cold weather, it may be appropriate to cover the ground to prevent freezing and, in some extreme cases, heating of the ground may be required.

Other concreting

Concrete reinforcing and formwork should not be frozen and be free from snow and ice.

Curing of concrete

Concrete may take longer to cure in cold conditions, and an additional six days may be required in extreme cases. Concrete may be covered with a rigid insulation to prevent freezing during curing periods. This is particularly useful for oversized slabs. Concrete should not be poured if the ground is frozen, or if the temperature is less than 2°C.

Concrete curing in cold weather conditions

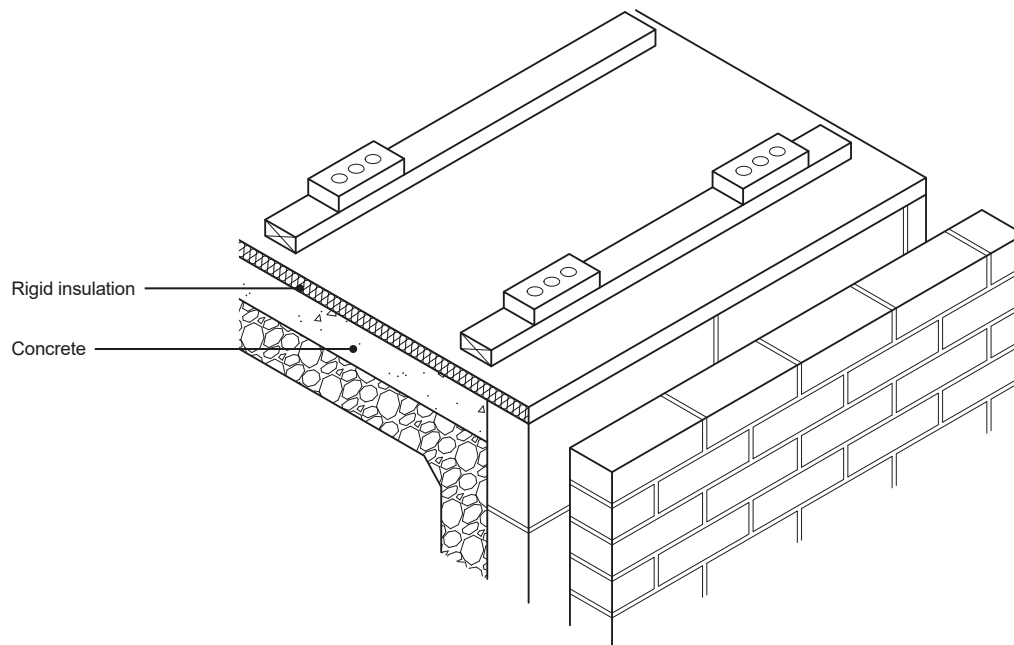

Concrete suitability

Concrete of the appropriate durability and strength should be used in all circumstances. The Table below gives details of the correct concrete for varying applications.

Please note: Non-cement based concrete products need prior approval by us.

Application	Ready mixed concrete	Site mixed concrete	Consistence class
Substructure Blinding (unreinforced) Backfilling	GEN1	N/A	S3
Substructure (unreinforced) Structural blinding Strip, trench, and mass filled foundations Concreting of cavity walls to ground level	GEN1	N/A	S3/S4 ⁽¹⁾
Floor (unreinforced and unsuspended) with screed added or other floor finish	GEN1	N/A	S2
Floor slab as finish (e.g. power float)	GEN2	N/A	S2
Garage floors (unreinforced and unsuspended)	GEN3	N/A	S2
Reinforced slabs (buildings and garages suspended or unsuspended)	RC35	N/A	S2
Superstructure	As specified by an Engineer	N/A	As specified by an Engineer
External works: Pathways	PAV1	ST5	S2
Bedding for paving slabs	GEN1	ST1	S1

Note:
1. Consistence class S3 should be used for strip foundation concrete and consistence class S4 should be used for trench fill foundation concrete.

Concrete mixes

Site mixed concrete

Site mixed concrete should generally be avoided unless it is for non-structural applications e.g. backfilling or bedding of paving slabs etc. There may be exceptional circumstances where site mixing is unavoidable. Where this is the case, extra caution must be taken to ensure that the correct mix proportion is used; delivery notes should be provided if necessary, and a provision for testing may be required.

Ready mixed concrete

Concrete must be mixed using the correct proportions of cement, sand, aggregate and water. Ready mixed concrete should be delivered as close as possible to the site works and should be poured immediately to prevent settlement or separation of the mix. Ideally, ready mixed concrete should be poured within two hours of the initial mixing at the concrete plant.

Ready mixed concrete should only be sourced from a supplier who has a quality control system in place to ensure the correct standard of concrete is delivered. The quality control scheme should be either QSRMC (Quality Scheme for Ready Mixed Concrete) or a relevant British Standard Kite mark scheme.

It is important to pass all design specifications of the concrete to the ready mixed supplier to ensure that the delivered concrete meets the design intention.

Delivery notes should be kept and made available for inspection if required.

Additional water should not be added to the concrete on-site, nor should the ready mixed concrete be poured into water-filled trenches unless the concrete has been specifically designed for this purpose.

Reinforcing

Reinforcing bars and mesh should be clean and free from loose rust and any other contaminants that may cause deterioration of the reinforcing material or the durability of the concrete.

Reinforcing bars and mesh should be placed in accordance with structural drawings; bars that are to be bent should be done so using the correct tools for the job.

Reinforcing bars in concrete beams

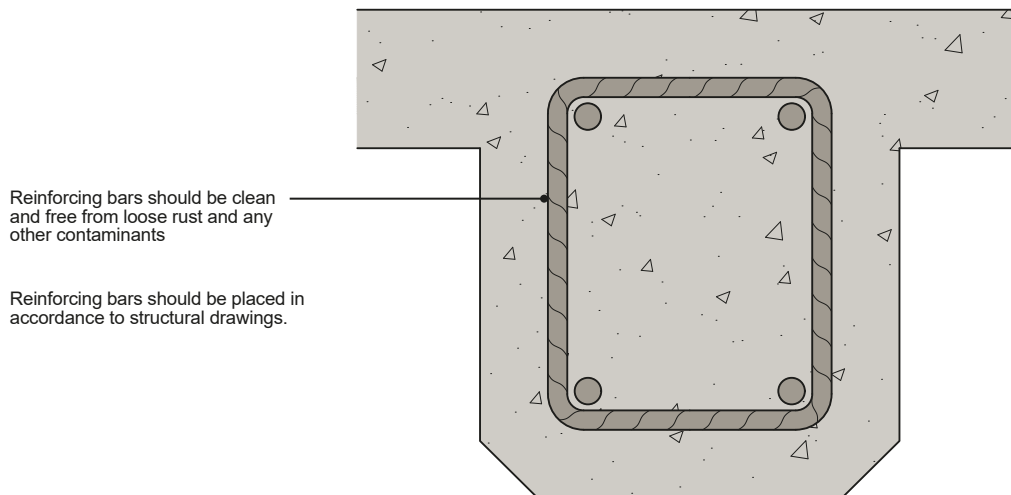

Position of bars on reinforced concrete slab

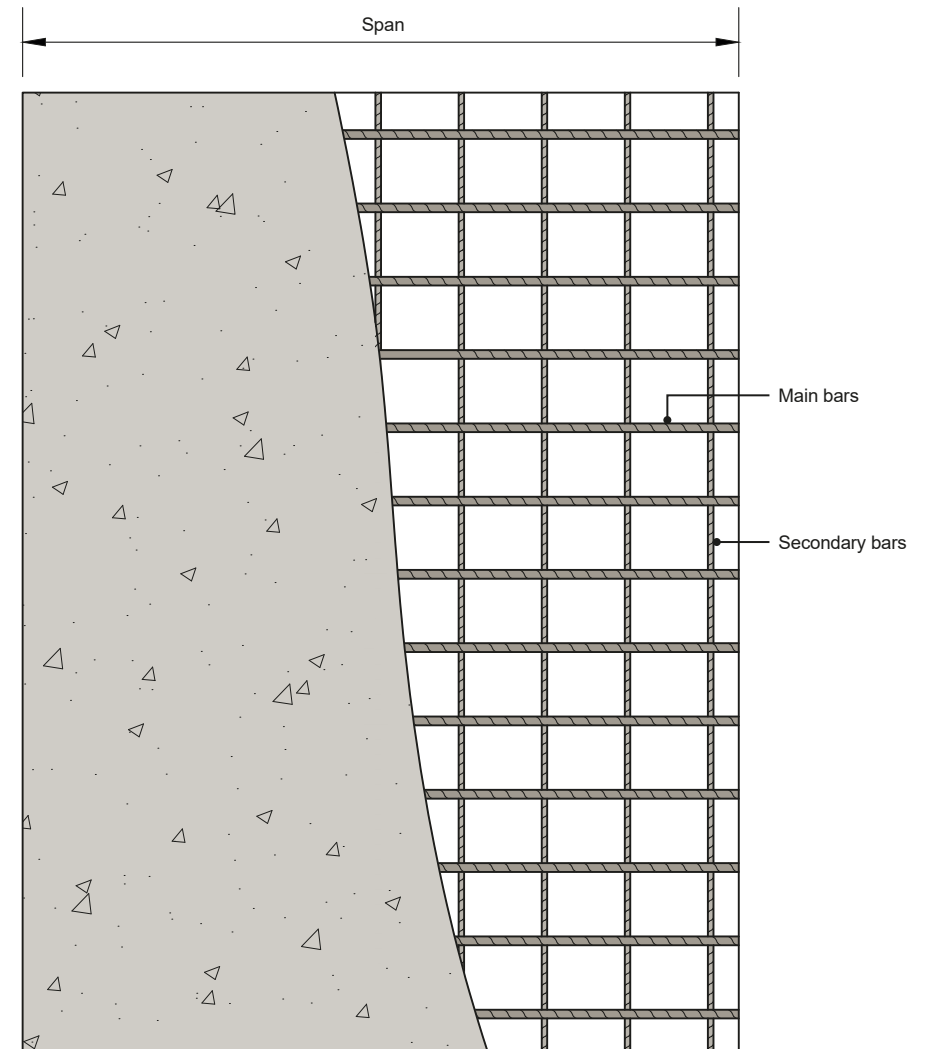

Reinforcing bars should be correctly positioned, ensuring there is appropriate concrete cover, and reinforcing mesh placed in the right direction (main bars parallel to span).

Reinforcing cover

An appropriate level of concrete cover should be provided to the reinforcement; the cover thickness will depend on the exposure of the concrete and its application. Concrete cover should be specified by an Engineer, or alternatively by using the table below.

Minimum concrete reinforcing cover

Application (concrete position)	Minimum cover (mm)
Concrete in direct contact with the ground	75
All external applications e.g. shuttered walling	50
Floor slabs and other applications where concrete is cast onto a membrane	40
Concrete over blinding concrete	40
Internal conditions	25

Reinforcing should be supported by proprietary chairs or spacers, and can be made of concrete, plastic or steel. The thickness and depth of a concrete spacer should not exceed 50mm x 50mm. Spacers should be placed at a maximum of 1m centres, and when supporting mesh should be staggered.

Position of spacers

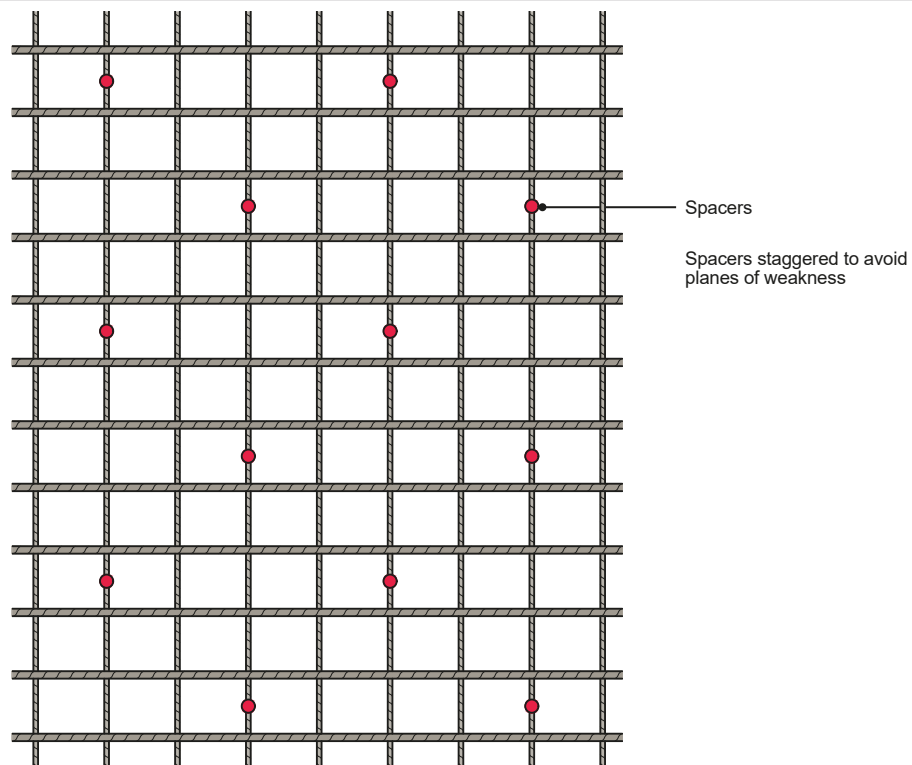

Admixtures

Admixtures should only be used if stipulated as part of the original design specification. If an admixture is to be proposed where it was not intended as part of the design, an Engineer must confirm that the admixture is appropriate and required.

It is important that the appropriate amount of admixture is applied to any mix. Any overdosing may cause concrete deterioration or poor workability.

Common admixtures

- Plasticisers - improve the workability of concrete, especially when pumped; they can also improve concrete adhesion, which is particularly enhanced when concrete is reinforced.
- Air entraining agents - increase the air void volume of concrete, which in turn produces a surface more resilient to cold weather, and is therefore ideally suited to outdoor conditions where cold weather exposure is high, such as pathways or roads.
- Accelerators - provide an improved curing time, but caution should be taken to allow for reasonable time to 'finish' the concrete.

Admixtures in cold weather

Admixtures may be used in cold weather, but usually will not assist in preventing concrete from freezing; therefore, they should not be relied upon to compensate for freezing conditions. The guidance for cold weather working should be followed in these circumstances.

Admixtures and reinforcing

Admixtures containing chloride will cause corrosion to occur, meaning they should not be used in concrete containing reinforcing.

Expansion/movement joints

Joints in concrete should be provided to prevent cracking caused by shrinkage; shrinkage will be less significant if the concrete is reinforced.

A larger number of expansion joints should be provided to concrete where weak spots may occur. This could include a narrowing width of floor slab for example.

Vibration and compaction of concrete

Reinforced concrete should be compacted using a vibrating poker, but care must be taken to ensure the concrete is not over-compacted and the concrete mix separated.

Curing of concrete

Concrete should be adequately cured before loads are applied. It is acceptable that masonry walls may be built up to damp proof course (DPC) on a foundation that is not fully cured; however, care must be taken to prevent any damage to the foundation. The concrete should be at least durable enough to carry the masonry.

The speed at which concrete mixes cure depends on the mix ratio and whether there are any additives within the concrete. Where curing time is critical, such as cast in-situ upper floors, curing times should be indicated as part of the design and formwork struck, as advised by an Engineer.

To prevent concrete curing too rapidly after initial drying, exposed concrete should be covered with hessian, polythene or sand. This prevents the surface drying too quickly and protects the concrete. This level of protection is particularly critical in hot or adverse weather conditions.

Standards referred to:

- BS 8110 Structural use of concrete.
- BS EN 1992-1-1 Design of concrete structures, general rules and rules for buildings (incorporating UK National Annex to Eurocode).
- BS 8500 Concrete - Complementary British Standard to BS EN 206-1.
- BS EN 206-1 Concrete. Specification, performance, production and conformity.
- BS EN 12620 Aggregates for concrete.
- BS EN 197 Cement. Conformity evaluation.

Cold weather working

To meet the Functional Requirements of this Technical Manual, the minimum working temperatures should not fall below 2°C when working with masonry. It is important that during cold weather periods, regular temperature readings should be taken.

Thermometers should be placed away from direct sunlight, preferably in a shaded area. When assessing the temperature, it is also important to consider wind chill and weather exposure, and make necessary allowances for sites that have a higher level of exposure.

Protection of materials

Covers should be provided to protect materials from frost, snow and ice, particularly bricks, blocks, sand and cement. Frozen materials should never be used under any circumstances.

Protection of blockwork

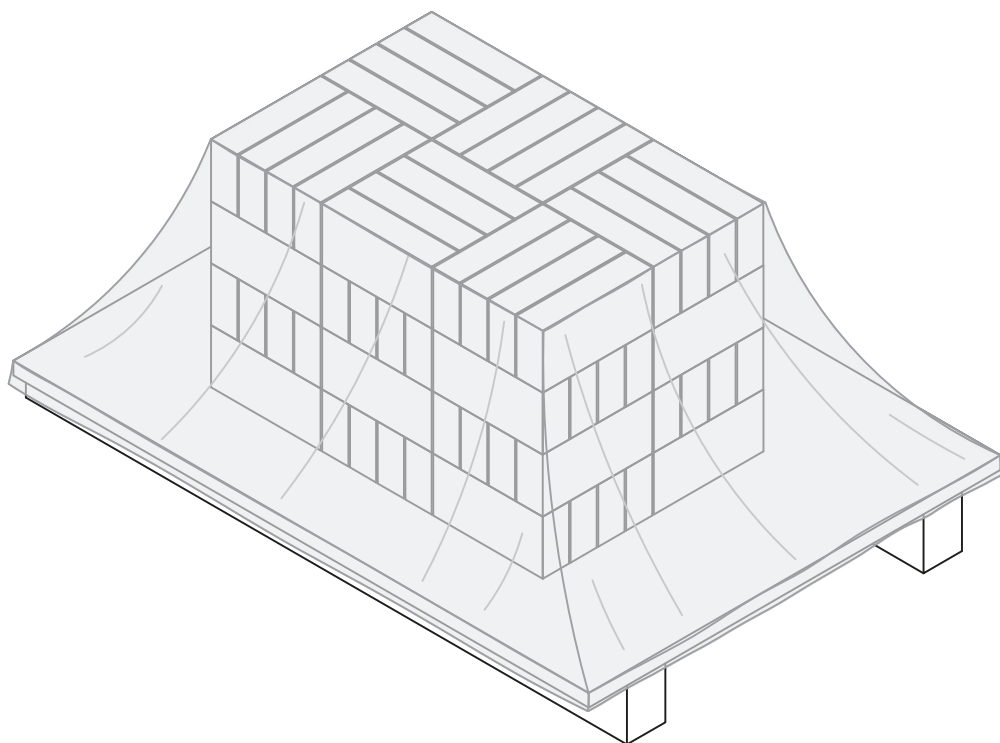

Protection of masonry walls

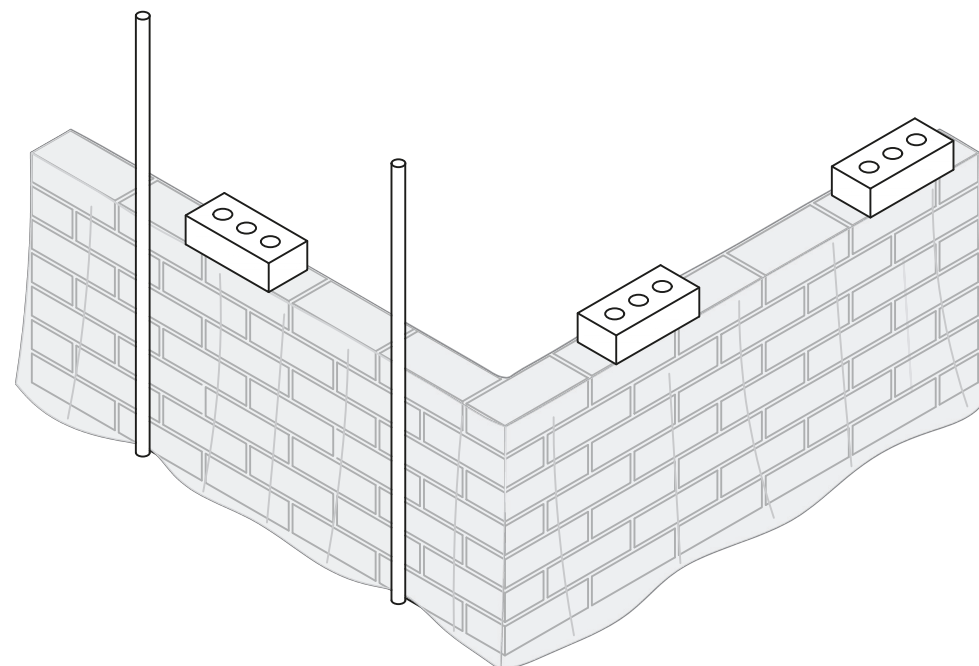

Protection of masonry

Any new walls or other masonry construction will require protection against frost where temperatures are expected to drop below 2°C. Ideally, all masonry should be protected with polythene or hessian. If temperatures are expected to fall to an extremely low level, insulation boards may be required, and heating may even be considered.

Finishes including rendering, plastering and screeds

Rendering should only be completed if the outside temperature is at least 2°C; there should be no frost within the construction that is to be rendered and, where possible, rendering should not take place where freezing weather conditions are anticipated prior to adequate curing.

No plastering or screeding should take place unless the building is free from frost. It is acceptable to use internal heating to warm the building effectively; however, it is important to ensure that heaters do not emit excessive vapour into the building. Adequate ventilation should be provided to allow moist air to escape. The building should be appropriately pre-heated before plastering, and continue to be heated whilst the plaster dries.

Masonry units

Masonry units should be of an appropriate durability to meet the design intention. The type of masonry unit to be used will affect the specification of the mortar. Masonry units with greater durability should be used where there is a higher potential for saturation or severe exposure to wind-driven rain. Refer to the masonry unit manufacturer when making this selection.

Due to difficulties in testing the durability of the exact batch proposed to be used, reclaimed bricks should not be used for Warranty purposes.

The following table is derived from PD 6697 - Durability of masonry in finished construction and provides guidance of the suitability of masonry in different areas of construction. This table should be read in conjunction with the following table 'Classification of micro conditions of exposure of completed masonry which gives further guidance on the masonry condition or saturation.

Please note: Non-cement based concrete products need prior approval by us.

Durability of masonry in finished construction (derived from PD 6697 - 2019)

Masonry condition or situation ^(A)	Quality of masonry units and appropriate mortar designations				Remarks
	Clay units	Calcium silicate units	Aggregate concrete bricks	Aggregate concrete, autoclaved aerated concrete blocks and manufactured stone units	
(A) Work below or near external ground level					
A1 - Low risk of saturation without freezing MX2.1	P – F0 and S0 or U – F0, F1 or F2 and S0, S1 or S2 in M12, M6 or M4	Without or with freezing Compressive strength class 20 or above in M4 or M2 (see remarks)	Without or with freezing Mean compressive strength 16.5 N/mm ² or above in M4	Without or with freezing a) of net density ≥ 1500 kg/m ³ ; or b) made with dense aggregate conforming to BS EN 12620; or c) having a mean net compressive strength ≥ 7.3 N/mm ² ; or d) most types of autoclaved aerated unit (see remarks) or e) all types of manufactured stone units. All in M4 or M2 (see remarks)	Some types of autoclaved aerated concrete block may not be suitable. The manufacturer should be consulted. In sulfate bearing ground conditions, the recommendations in 6.2.9.4 (see PD 6697:2019) should be followed. Where designation M2 mortar is used it is essential to ensure that all masonry units, mortar and masonry under construction are protected fully from saturation and freezing. Some manufacturers of clay units do not recommend the use of their U -F1 units for work below or near external ground level.
A2 - High risk of saturation without freezing MX2.2	U – F1 or F2, and S1 or S2 in M12, M6 or M4 unless a manufacturer advises against the use of F1	Compressive strength class 20 or above in M6 or M4	Mean compressive strength 16.5 N/mm ² or above in M6 or M4	As for A1 in M6 or M4	Masonry most vulnerable in situations A2 and A3 is located between 150 mm above and 150 mm below finished ground level. In this zone masonry will become wet and can remain wet for long periods, particularly in winter. Where S1 clay units in designation M6 mortar are used in A2 or A3 locations, the recommendations in 6.2.9.4 (see PD 6697:2019) should be followed.
A3 - High or low risk of saturation with freezing MX3.1, MX3.2	U – F2 and S2 in M12 or M6 (see remarks)	Compressive strength class 20 or above in M6 or M4	Mean compressive strength 22 N/mm ² or above in M6 or M4	As for A1 in M6	In conditions of highly mobile groundwater, consult the manufacturer on the selection of materials (see 6.2.8.1.10 to 6.2.8.1.14).
(B) Masonry DPCs (masonry DPC's are not acceptable for Warranty purposes)					
(C) Unrendered external walls (other than chimneys, cappings, copings, parapets, sills)					
C1 - Low risk of saturation MX3.1, MX4, MX5	U – F2 and S2 in M12, M6 or M4	Compressive strength class 20 or above in M4 or M2 (see remarks)	Mean compressive strength 7.3 N/mm ² or above in M4	Any in M4 or M2 (see remarks)	To minimize the risk of saturation, walls should be protected by roof overhang and other projecting features. However, such details may not provide sufficient protection to walls in conditions of very severe driving rain (see 6.2.7.4 of PD 6697:2019). Certain architectural features, e.g. brick masonry below large glazed areas with flush sills, increase the risk of saturation (see 6.2.8.5 of PD 6697:2019).
C2 - High risk of saturation MX3.2, MX4, MX5	U – F2 and S2 in M12 or M6 (see remarks)	Compressive strength class 20 or above in M4	Mean compressive strength 18 N/mm ² or above in M4	Any in M4	Where designation M2 mortar is used it is essential to ensure that all masonry units, mortar and masonry under construction are protected fully from saturation and freezing.
D) Rendered external walls (B) (other than chimneys, cappings, copings, parapets, sills)					
Rendered external walls. Any exposure condition.	U – F1 or F2 and S1 or S2 in M12, M6 or M4 (see remarks)	Compressive strength class 20 or above in M4 or M2 (see remarks)	Mean compressive strength 7.3 N/mm ² or above in M4	Any in M4 or M2 (see remarks)	Rendered walls are usually suitable for most wind-driven rain conditions (see 6.2.7.4 of PD 6697:2019). Where S1 clay units are used, the recommendations in 6.2.9.4 (see PD6697:2019) should be followed for the jointing mortar and the base-coat of render. Clay units of F1/S1 designation are not recommended for the rendered outer leaf of a cavity wall with full fill insulation (see 6.2.7.4.2.9 of PD 6697:2019) For Warranty purposes render on an external leaf of clay bricks (F2, S1, or F1, S1 designation bricks BS EN771) in severe or very severe exposures is not permitted where the cavity is to be fully filled with insulation.

Masonry condition or situation ^(A)	Quality of masonry units and appropriate mortar designations				Remarks
	Clay units	Calcium silicate units	Aggregate concrete bricks	Aggregate concrete, autoclaved aerated concrete blocks and manufactured stone units	
(E) Internal walls and inner leaves of cavity walls					
Internal walls and inner leaves of cavity walls MX1	P – F0 and S0 or U – F0, F1 or F2 and S0, S1 or S2 in M12, M6, M4 or M2 (see remarks)	Compressive strength class 20 or above in M4 or M2 (see remarks)	Mean compressive strength 7.3 N/mm ² or above in M4 (see remarks)	Any in M4 or M2 (see remarks)	Where designation M2 mortar is used it is essential to ensure that all masonry units, mortar and masonry under construction are protected fully from saturation and freezing
(F) Unrendered parapets (other than cappings and copings)					
F1 - Low risk of saturation with freezing, e.g. low parapets on some single storey buildings MX3.1, MX4	U – F2 and S2 in M12, M6 or M4	Compressive strength class 20 or above in M4	Mean compressive strength 22 N/mm ² or above in M4	a) Of net density ≥ 1 500 kg/m ³ ; or b) Made with dense aggregate conforming to BS EN 12620; or c) Having a mean net compressive strength ≥ 7.3 N/mm ² ; or d) Most types of autoclaved aerated unit (see remarks); or e) All types of manufactured stone unit f) All in M4	Most parapets are likely to be severely exposed irrespective of the climatic exposure of the building as a whole. Copings and DPCs should be provided wherever possible. Some types of autoclaved aerated concrete block may not be suitable. The manufacturer should be consulted.
F2 - High risk of saturation with freezing e.g. where a capping only is provided for the masonry MX3.2, MX4	U – F2 and S2 in M12 or M6 (see remarks)	Compressive strength class 20 or above in M4	Mean compressive strength 22 N/mm ² or above in M4	As for F1 in M6	
(G) Rendered parapets (other than cappings and copings)					
Rendered parapets MX3.1, MX3.2, MX4	U – F1 or F2 and S1 or S2 in M12, M6 or M4 (see remarks)	Compressive strength class 20 or above in M4	Mean compressive strength 7.3 N/mm ² or above in M4	Any in M4	Single-leaf walls should be rendered only on one face. All parapets should be provided with a coping. Where S1 clay units are used, the recommendations in 6.2.8.4 (see PD6697:2019) should be followed.
(H) Chimneys					
H1 - Unrendered with low risk of saturation MX3.1, MX4, MX5	U – F2 and S2 in M12, M6 or M4 (see remarks)	Compressive strength class 20 or above in M4 (see remarks)	Mean compressive strength 12 N/mm ² or above in M4 (see remarks)	Any in M4	Chimney stacks are normally the most exposed masonry on any building. Because of the possibility of sulfate attack from flue gases the recommendations in 6.2.9.4 (see PD6697:2019) should be followed.
					Brick masonry and tile cappings cannot be relied upon to keep out moisture. The provision of a coping is preferable.
H2 - Unrendered with high risk MX3.2, MX4, MX5	U – F2 and S2 in M12 or M6 (see remarks)	Compressive strength class 20 or above in M4 (see remarks)	Mean compressive strength 16.5 N/mm ² or above in M4 (see remarks)	a) Of net density ≥ 1 500 kg/m ³ ; or b) Made with dense aggregate conforming to BS EN 12620; or c) Having a mean net compressive strength ≥ 7.3 N/mm ² ; or d) Most types of autoclaved aerated unit (see remarks) or e) All types of manufactured stone unit	Some types of autoclaved aerated concrete block may not be suitable for use in situation H2. The manufacturer should be consulted.
H3 - Rendered MX3.1, MX3.2, MX4, MX5	U – F1 or F2 and S1 or S2 in M12, M6 or M4 (see remarks)	Compressive strength class 20 or above in M4 (see remarks)	Mean compressive strength 7.3 N/mm ² or above in M4 (see remarks)	Any in M6	Where S1 clay units are used, see 6.2.8.4.
(I) Cappings, copings and sills					
Cappings, copings and sills MX3	U – F2 and S2 in M12	Compressive strength class 30 or above in M6	Mean compressive strength 33 N/mm ² or above in M6	a) Of net density ≥ 1 500 kg/m ³ ; or b) Made with dense aggregate conforming to BS EN 12620; or c) Having a mean net compressive strength ≥ 7.3 N/mm ² ; or d) All types of manufactured stone unit e) All in M6	Autoclaved aerated concrete blocks are not suitable for use in situation I. Where cappings or copings are used for chimney terminals, the recommendations in 6.2.8.4 (see PD6697:2019) should be followed. DPCs for cappings, copings and sills should be bedded in the same mortar as the masonry units.
(J) Freestanding boundary and screen walls (other than cappings and copings). (This section is not produced for Warranty purposes. For further information please see PD 6697-2019)					

Masonry condition or situation ^(A)	Quality of masonry units and appropriate mortar designations				Remarks
	Clay units	Calcium silicate units	Aggregate concrete bricks	Aggregate concrete, autoclaved aerated concrete blocks and manufactured stone units	
(K) Earth retaining walls (other than cappings and copings)					
K1 - With water-proofing on retaining face and coping MX3.1, MX3.2, MX4	U – F2 and S2 in M12 or M6. Refer to (B) for units from foundation to 150 mm above ground level.	Compressive strength class 20 or above in M6 or M4	Mean compressive strength 16.5 N/mm ² or above in M6	a) of net density $\geq 1\,500\text{ kg/m}^3$; or b) made with dense aggregate conforming to BS EN 12620; or c) having a mean net compressive strength $\geq 7.3\text{ N/mm}^2$; or d) most types of autoclaved aerated unit (see remarks); or e) all types of manufactured stone unit f) All in M4	Because of possible contamination from the ground and saturation by ground waters, in addition to subjection to severe climatic exposure, masonry in retaining walls is particularly prone to frost and sulfate attack. Careful choice of materials in relation to the methods for exclusion of water recommended in 6.2.8 (see PD6697:2019) is essential. It is strongly recommended that such walls be backfilled with freedrainng materials. The provision of an effective coping with a DPC (see 6.2.8 of PD 6697:2019) and waterproofing of the retaining face of the wall (see 6.8.6 of PD 6697:2019) is desirable. Some types of autoclaved aerated concrete block are not suitable for use in situation K1; the manufacturer should be consulted.
K2 -With coping or capping but no water-proofing on retaining face MX3.1, MX3.2, MX4, MX5	Consult the manufacturer	Compressive strength class 30 or above in M6	Mean compressive strength 33 N/mm ² or above in M12 or M6	As for K1 but in M12 or M6 (see remarks)	Some aggregate concrete blocks are not suitable for use in situation K2; the manufacturer should be consulted.
(L) Drainage and sewage, e.g. inspection chambers, manholes					
L1 - Surface water MX3.1, MX3.2, MX5	Max. water absorption 7 % in M12 (in line with historic DPC and engineering brick categories) or F2 and S2 in M12 (see remarks)	Compressive strength class 20 or above in M6 or M4	Mean compressive strength 22 N/mm ² or above in M4	a) Of net density $\geq 1\,500\text{ kg/m}^3$; or b) Made with dense aggregate conforming to BS EN 12620; or c) Having a mean net compressive strength $\geq 7.3\text{ N/mm}^2$; or d) All types of manufactured stone unit in M4	If sulfate ground conditions exist, the recommendation in 6.2.8.4 (see PD6697:2019) should be followed. Some types of autoclaved aerated block are not suitable for use in situation L1; the manufacturer should be consulted."
L2 - Foul drainage (continuous contact with masonry) MX3.1, MX3.2, MX5	Max. water absorption 7 % in M12 (in line with historic DPC and engineering brick categories) or F2 and S2 in M12 (see remarks)	Compressive strength class 50 or above in M6 (see remarks)	Mean compressive strength 48 N/mm ² or above with cement content $\geq 350\text{ kg/m}^3$ in M12 or M6	Not suitable	Some types of calcium silicate brick are not suitable for use in situations L2 or L3; the manufacturer should be consulted.
L3 - Foul drainage (occasional contact with masonry) MX3.1, MX3.2, MX5	Max. water absorption 7 % in M12 (in line with historic DPC and engineering brick categories) or F2 and S2 in M12 (see remarks)	Compressive strength class 20 or above in M6 or M4 (see remarks)	Mean compressive strength 48 N/mm ² or above with cement content $\geq 350\text{ kg/m}^3$ in M12 or M6	Not suitable	
A) For the classification of micro conditions of exposure of completed masonry MX1, 2, 3, 4 and 5, see BS EN 1996-2:2006, Annex A, and NA to BS EN 1996-2:2006. B) For Warranty purposes a specialist render system and mortar should be employed for parapets, chimneys, retaining walls and walls below DPC. LD - Clay masonry units with a low gross density for use in protected masonry. HD - Clay masonry unit for unprotected masonry as well as clay masonry unit with high gross dry density for use in protected masonry.					

The table below should be read in conjunction with table above 'Durability of masonry in finished construction'. The table below provides further information on the environment in which the masonry may be suitable.

Classification of micro conditions of exposure of completed masonry (reproduced from BS EN 1996-2:2006)

Class	Micro condition of masonry	Examples of masonry in this condition
MX1	In a dry environment	Interior of buildings for normal habitation and for offices, including the inner leaf of external cavity walls not likely to become damp. Rendered masonry in exterior walls, not exposed to moderate or severe driving rain, and isolated from damp in adjacent masonry or materials.
MX2	Exposed to moisture or wetting	
MX2.1	Exposed to moisture but not exposed to freeze/thaw cycling or external sources of significant levels of sulfates or aggressive chemicals.	Internal masonry exposed to high levels of water vapour, such as in a laundry. Masonry exterior walls sheltered by overhanging eaves or coping, not exposed to severe driving rain or frost. Masonry below frost zone in well drained non-aggressive soil.
MX2.2	Exposed to severe wetting but not exposed to freeze/thaw cycling or external sources of significant levels of sulfates or aggressive chemicals.	Masonry not exposed to frost or aggressive chemicals, located: in exterior walls with capping's or flush eaves; in parapets; in freestanding walls; in the ground; under water.
MX3	Exposed to wetting plus freeze/thaw cycling	
MX3.1	Exposed to moisture or wetting and freeze/thaw cycling but not exposed to external sources of significant levels of sulfates or aggressive chemicals.	Masonry as class MX2.1 exposed to freeze/thaw cycling
MX3.2	Exposed to severe wetting and freeze/thaw cycling but not exposed to external sources of significant levels of sulfates or aggressive chemicals.	Masonry as class MX2.2 exposed to freeze/thaw cycling.
MX4	Exposed to saturated salt air seawater or de-icing salts	Masonry in a coastal area. Masonry adjacent to roads that are salted during the winter
MX5	In an aggressive chemical environment	Masonry in contact with natural soils or filled ground or groundwater, where moisture and significant levels of sulfates are present. Masonry in contact with highly acidic soils, contaminated ground or groundwater. Masonry near industrial areas where aggressive chemicals are airborne.
<p>Note: In deciding the exposure of masonry the effect of applied finishes and protective claddings should be taken into account.</p>		

Acceptable assumed equivalent mixes for prescribed mortars (reproduced from BS EN 1996-1 UK National Annex to Euro Code 6: Design of Masonry Structures Table NA.2)

Compressive strength class a)	Prescribed mortars (proportion of materials by volume) (see note)				Mortar designation	Suitable for use in environmental condition
	Cement b): Lime : Sand with or without air entrainment	Cement b): Sand with or without air entrainment	Masonry cement c): Sand	Masonry cement d): Sand		
M12	1: 0 to ¼: 3	1 : 3	Not suitable	Not suitable	(i)	Severe (S)
M6	1 : ½ : 4 to 4 ½	1 : 3 to 4	1 : 2 ½ to 3 ½	1 : 3	(ii)	Severe (S)
M4	1 : 1 : 5 to 6	1 : 5 to 6	1 : 4 to 5	1 : 3 ½ to 4	(iii)	Moderate (M)
M2	1 : 2 : 8 to 9	1 : 7 to 8	1 : 5 ½ to 6 ½	1 : 4 ½	(iv)	Passive (P)
<p>a) The number following the M is the compressive strength for the class at 28 days in N/mm². b) Cement or combinations of cement in accordance with N.A.2.3.2, except masonry cements. c) Masonry cement in accordance with N.A. 2.3.2 (inorganic filler other than lime). d) Masonry cement in accordance with N.A. 2.3.2 (lime).</p> <p>Note 1: When the sand portion is given as, for example, 5 to 6, the lower figure should be used with sands containing a higher proportion of fines whilst the higher figure should be used with sands containing a lower proportion of fines.</p> <p>Note 2: For Class 2 of execution control site compressive strength testing is not required for these traditional mixes and checking of prescribed mortars should only be done by testing the proportions of the constituents</p>						

Specification of mortars for masonry

Mortar for masonry can be:

- General purpose or thin layer or lightweight.
- Factory made (pre-batched or pre-mixed) or semi-finished factory made (both to BSEN998-2) or site made (to BSEN1996-2).
- Designed (performance concept) or prescribed (recipe concept).

Designed masonry mortar has a composition and method of manufacture chosen by the producer in order to achieve specified properties.

Prescribed masonry mortar is made in predetermined proportions whose properties are assumed from the stated proportion of constituents.

Historically mortars were generally specified in terms of a prescription or recipe as, for example, in BS 5628. The updated British Standard for masonry mortar, BS EN 998-2, is a performance based standard.

Mortar should be specified, manufactured and installed in accordance with:

- BS EN 1996: Design of masonry structures.
- BS EN 998-2: Specification for mortar for masonry.
- PD 6678: Guide to the specification of masonry mortar.
- PD 6697: Recommendations for the design of masonry structures to BSEN1996-1-1 and BSEN1996-2.

Specification of factory-made or semi-finished factory-made to BS EN 998-2

For prescribed mortars:

- The prescribed mortar specification should be drafted so that the quality is controlled by stated compositional requirements.
- The compressive strength shall be declared using publicly available references establishing the relationship between same mix proportions of the same constituents and compressive strength. The proportion of the prescribed constituents required to provide the stated "M" values for prescribed masonry mortars are given in table NA.2 of the National Annex to BS EN 1996-1-1.
- The mix proportions by volume or by weight of all the constituents shall be declared by the manufacturer. The manufacturer shall verify the conformity of the mortar to the specification by referring to any production records and delivery documentation. CE marking/UKCA marking of prescribed factory made mortar signifies that the product conforms to the European Commission's Construction Products Directive. Conformity is demonstrated by initial type testing and factory production control to BS EN 998-2.

For designed mortars:

- The compressive strength of masonry mortar shall be declared by the manufacturer. The manufacturer may declare the compressive strength class with the compressive strength designated by a 'M' followed by the compressive strength class in N/mm², which it exceeds.
- CE marking/UKCA marking of a designed factory made mortar signifies that the product conforms to the essential requirements of the European Commission's Construction Products Directive (CPD). Producing designed factory made mortar in accordance with BS EN 998-2 ensures that the mortar conforms to the CPD and can therefore be CE marked/UKCA marked.
- BS EN 998-2, Annex ZA specifies that if designed mortar carries the CE mark/UKCA mark, the factory production control system will have been certified by a notified body (third party certification body).

Specification of site-made mortar to BS EN 1996-2.

Prescribed and designed mortars:

- The design specification should state the required product performance characteristics and the means of their verification including the requirements for sampling and frequency of testing.
- Where the designer is satisfied that a prescriptive specification will provide the required performance, a detailed specification of the constituent materials, their proportions and the method of mixing may be given either on the basis of tests carried out on trial mixes and/or on the basis of authoritative publicly available references acceptable in the place of use.
- When the mix prescription is not given in the design specification, the detailed specification of constituent materials, their proportions and the method of mixing should be selected on the basis of tests carried out on trial mixes and/or on the basis of authoritative publicly available references acceptable in the place of use. When tests are required, they should be carried out in accordance with the design specification and BS EN 1015. When test results indicate that the mix prescription is not giving the required performance characteristics, the mix prescription should be amended and if it is part of the design specification any amendments should be agreed with the designer.
- Where designed mortars are manufactured on site, and not within a factory control system, the mortar specification should state how conformity is to be assessed. This can range from infrequent but regular testing of samples to visual inspection and random testing of samples with statistical analysis of results. The specification should describe the supervision, inspection and testing that is required in order to confirm that the mortar conforms to the specifiers chosen BS EN 998-2 requirements.

Testing and conformity evaluation

Conformity evaluation methods for both factory and site made masonry mortar can range from examination of production records to testing and comparison of the results with tabulated values for known compositions.

General notes

Mortar in masonry shall be sufficiently durable to resist the relevant micro exposure conditions for the intended life of the building and shall not contain constituents which can have a detrimental effect on the properties or durability of the mortar or abutting materials. Acceptable masonry unit specifications and mortar can be selected from PD 6697:2019. It is strongly recommended that you check with the manufacturers for suitability in specific applications when making your selection.

Mortar should be designed to take account of any requirement for bed joint reinforcement.

Factory made mortars and pre-batched mortars shall be used:

- In accordance with the manufacturer's instructions, including mixing time and type of mixer.
- Before the expiry of the workable life stated by the manufacturer.
- Taking account of weather conditions.

Site made mortar shall be:

- Ready for use when it is discharged from the mixer, and no subsequent additions of binders, aggregates, admixtures or water should be made.
- Be mixed so as to have a sufficient workability for it to fill the space into which it is placed, without segregation.
- Used before its working life has expired.
- Used taking account of weather conditions.

Standards referred to:

- BS 6399 Loadings for buildings.
- BS 8103 Structural design of low rise buildings.
- BS 187 Specification for calcium silicate (sand lime and flint lime) bricks.
- BS 3921.
- BS 5628 Parts 1, 2 and 3 Code of Practice for use of masonry.
- BS EN 771-1.
- BS EN 998 Specification for mortar for masonry.
- BS EN 1996-1 Design of masonry structures.
- PD 6697:2019.

Corrosion protection and protective coatings

Corrosion protection to steelwork (including lintels)

All materials on buildings are subject to wear during use, this is caused by mechanical, chemical, electrochemical, thermal, microbiological and radiation related impacts. Mechanical reactions lead to wear, chemical and electrochemical reactions cause corrosion.

Corrosion is defined as the physical interaction between a metal and its environment which results in changes to the metals properties, and which may lead to significant functional impairment of the metal, the environment, or the technical system of which they form part of (BS EN ISO 8044).

Corrosion resistance is the ability of a metal to maintain its operational capability in a given corrosion system. When selecting suitable construction materials which are protected to resist corrosion during its service life, it is important to consider the building, its location, the surrounding environment, the atmosphere and climatic conditions.

There are several types of corrosion that must be considered to ensure that the material(s) selected will not corrode and lead to functional impairment:

- Uniform surface corrosion.
- Electrolytic corrosion.
- Crevice corrosion.
- Pitting corrosion.
- Stress corrosion.
- Contact corrosion.

Steel lintels in coastal locations

Steel lintels in coastal locations, used in both leaves of an external wall openings on projects within 500m of the shoreline, should be austenitic stainless steel and, in addition protected by a separate damp proof system/ cavity tray.

For sites between 500m and 5km of the shoreline, the lintel manufacturer should confirm their product is suitable for use in this environment– if not made from austenitic stainless steel and confirm will remain durable for 60 years. The durability of this element should not be reliant on maintenance

Standards

- ISO 8044 - Corrosion of metals and alloys - Basic terms and definitions.
- ISO 9223 - Corrosion of metals and alloys - Corrosively of atmospheres - Classification.
- ISO 9224 - Corrosion of metals and alloys - Corrosively of atmospheres - Guiding values for the corrosively categories.
- ISO 12944-2: Paints and varnishes - Corrosion protection of steel structures by protective paint systems - Part 2: Classification of environments.
- BRE Digest 301 - Corrosion of metals by wood.
- PD 6484 - Commentary on corrosion at bi-metallic contacts and its alleviation.

Note: The CWCT Technical Note 24 provides guidance on corrosion and corrosion protection to cladding.

Protective coatings and finishes to metals

All metals must have a suitable protective coating to minimise or prevent corrosion during its life and be selected to comply with the appropriate standards and with the corrosion category described in the following table.

The classification of environmental corrosion conditions has been taken from BS EN ISO 9223 Table 4 and BS EN ISO 12944-4 Table 1. This provides a verbal description of the corrosion categories. Note: to determine the corrosion rates for aluminium, copper, steel and zinc, please refer to the standards listed.

Classification of Environmental Corrosion Conditions - Reproduced from BS EN ISO 9223 Table 4 and BS EN ISO 12944-4 Table 1

Corrosion Category C	Corrosion Level	Indoor Environment	Outdoor Environment (Distances are specified from the coastal shore line)
C1	Very low	Heated spaces with low relative humidity and insignificant pollution e.g. offices, schools, museums.	Dry or cold zones with a very low pollution environment or times of wetness.
C2	Low	Unheated spaces with varying temperature and humidity, low pollution and where condensation may occur e.g. storage depots, light industry, sports halls.	Temperate zones to dry or cold zones with a low pollution environment e.g. Rural areas and small towns more than 10km from the coast or an estuary.
C3	Medium	Spaces with moderate frequency of condensation and pollution from production processes e.g. Residencies, Food processing plants, laundries, breweries, dairies.	Temperate zones with a medium pollution environment or small effects from chlorides, e.g. Urban and industrial areas with moderate sulphur dioxide pollution, coastal areas and estuaries with low salinity (approximately 5-10km).
C4	High	Spaces with a high frequency of condensation and pollution from production processes e.g. Boatyards, industrial processing plants and swimming pools.	Temperate zones, atmospheric environment with medium pollution and medium effects from chlorides e.g. polluted urban areas, industrial areas, coastal areas and estuaries with moderate salinity (approximately 1-5km) and areas exposed to de-icing salts.
C5	Very High	Spaces with very high frequency of condensation and pollution from production processes, e.g. Buildings with high levels of pollution and condensation.	Temperate to sub-tropical zones, high pollution area or a substantial effect from chlorides, e.g. Industrial areas, coastal areas (approximately 500m-1km), sheltered positions on the coastline (without salt spray).
CX	Extreme	Spaces with almost permanent condensation or periods of exposure to extreme humidity effects and with a high concentration of pollution.	Tropical zones with high sulphur dioxide pollution including the effects of chlorides, e.g. industrial areas with high humidity and an aggressive atmosphere, coastal (approximately 0-500m) and offshore areas with high salinity (occasional salt spray).

For Warranty purposes:

- Exposed steel frame construction used on sites with an atmospheric corrosivity of C4 or C5 to BS EN ISO 12944, including sites within 500m from a coastal shoreline, should be galvanised to a rate of 710 g/m².
- Decorative finishes must be compatible with the protective coat specification. Refer to BS EN 12944 'paints and varnishes: corrosion protection of steel structures by protective paint systems' and the manufacturers recommendations.
- Any section of previously galvanised or other protected steel which is then cut or drilled must be provided with appropriate remediation to the exposed parts of steel to ensure adequate corrosion protection is maintained.
- The designer should specify the protective coating system where any steelwork is to be welded.
- Surface preparation should be to BS EN 12944-4.
- The use of Intumescent paint for achieving fire protection should be compatible with any corrosion protective coating applied and the manufacturer's guidance should be followed.

Fixings

Fixings that are exposed to weathering, moisture and corrosive environments or applications where concentrations of corrosive agents may accumulate should be made from high grade austenitic stainless steel (e.g. A4) or a protective coating suitable for the corrosion category described in the table above.

Roof fixings

In addition to the guidance found in the 'Roofs' section, the following is applicable:

- For clay, concrete and slate roofing a full roof fixing specification from the slate or tile manufacture must be provided and the exposure and orientation of the site taken into account.
- All fixings must be durable for the environment location.
- For metal cladding:
 - The designer must establish the environment's corrosivity when specifying metal cladding for roofs in coastal locations as well as the potential for wind uplift and movement in a cladding system during severe wind conditions, particularly over party wall positions.
 - The designer should ensure capillary action at the overlapped joints is prevented which with high saline water could also cause pitting corrosion to take place, leading to the failure of the roof panels.

Durability of fixings

ISO 12944 also classifies three different durability ranges 'low, medium & high' for protective paint systems. Therefore, in severe and very severe environments, external paints and varnishes, and other protective coatings must be chosen to have a 'high' durability rating.

Whilst the durability range is not a 'guarantee time', consideration has to be made to the Functional Requirements of this Technical Manual (see the Service Life table at the end of this section).

Due to the environment, certain materials and particularly the finishes may require on-going maintenance in order to keep a satisfactory finish e.g. balcony timber decking. In these circumstances it will be the building owner's responsibility to ensure that regular maintenance of exposed components and finishes is undertaken to ensure they perform correctly. Maintenance plans will need to be in place during the lifetime of the building to ensure premature failure of coatings or components is avoided.

Materials, products and building systems should be chosen to take into account wind driven rain exposure maps.

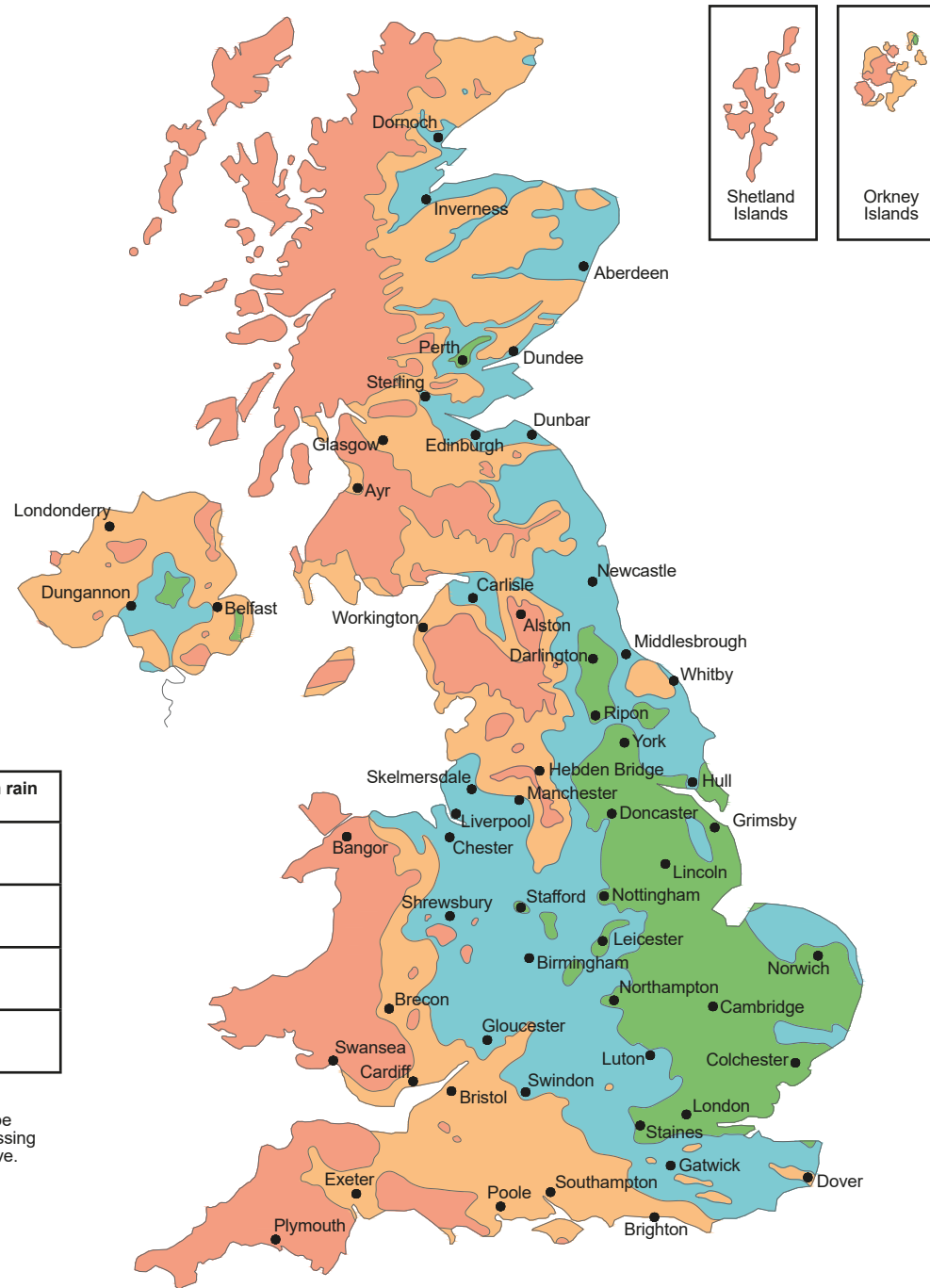

Exposure zones		Exposure to wind driven rain (litres/m ² per spell)
Very severe		100 or more
Severe		56.5 to less than 100
Moderate		33 to less than 56.5
Sheltered		less than 33

Note:
Variations to the exposure shown on the map can only be made by site-specific calculations using BS 8104 "Assessing exposure of walls to wind driven rain" and the table above.

C.

Appendix C

C.2

**Suitability of Products and
Systems**

Suitability of 'products'

It is important to ensure that products used in construction:

1. Meet the requirements of British Standards, Codes of Practice or equivalent European Standards current at the time of application, AND/OR;
2. Hold full third party product approval from an independent approval body which is accepted by us. This could either be a UKAS, European equivalent product conformity accredited organisation or other body accepted by us, which looks at the product/system as a whole and reports on its suitability and scope of accepted use. Such third party approval can assist in demonstrating compliance with our Warranty, but, the Functional Requirements in the Technical Manual must also be complied with. There are also certain systems and products which whilst they may hold a third party approval, represent an enhanced Warranty risk and are not acceptable to us. If in doubt please contact our Technical team for further clarification.
3. Where a corresponding Euro Standard exists, bear CE marking in accordance with the Construction Products Directive. This shall be supported by evidence of testing carried out on the product - CE marking is acceptable until 30th June 2025 for construction products to the GB market.

Third party product approval

Where a third party approval is proposed to assist in demonstrating meeting our Technical Manual requirements, the details of the testing body accreditation will need to be supplied, as well as the certification document.

The third party product conformity approval certificate 'should cover' following areas, relevant to the use of the product:

- Structural integrity, including serviceability of product.
- Safety in case of fire.
- Hygiene, Health & Environment including:
 - a) Vapour permeability and moisture resistance.
 - b) Water tightness.
 - c) Release of dangerous substances.
- Safety in use (where appropriate).
- Sound Insulation.
- Thermal performance, air tightness and movement characteristics.
- Durability; including:
 - a) Compatibility of materials (interaction between components, structural or otherwise).
 - b) Longevity of materials (identifying it achieves a 60 year service life in accordance with CML requirements where used in the structure or lesser period where identified in the Service Life table contained within this section of the Manual).
 - c) Maintenance issues.

Please note:

- We will require to assess the third party approval to determine if it provides sufficient information to confirm the product or system meets the requirements of this Technical Manual and that it is being used within the scope of that approval.
- Some of the above factors are not always included or do not take account of specific risk areas that our Warranty requires to be addressed.
- A product may not have been tested for the particular application on site. To avoid doubt, Developers and Builders should seek clarification from the Warranty provider, that the third party accreditation for the product/system will be acceptable.
- Certain systems and products which hold third party certification may not be acceptable as they are considered an enhanced risk for Warranty cover purposes. Please refer to our Technical team for further clarification.

European Technical Assessment (ETA)

Products or systems with an ETA certificate will need to be reviewed by our Technical Team as these do not always potentially cover all the factors that a full third party product conformity approval certificate may provide and aspects such as durability or the quality management systems that are in place may not be included.

In addition:

- Where bearing a CE marking/UKCA marking in accordance with the

Construction Products Directive, this shall be supported by evidence of the testing carried out on the product.

- CE marking is acceptable until 30th June 2025 for construction products to the GB market.

Construction products that do not meet the Warranty requirements may not be acceptable for Warranty approval. It is advised that the design team must approach the Warranty provider early in the design stage to discuss the viability of the use of such a material, and determine what further independent third-party testing may be required in advance of the final design proposal.

Products that hold full third-party product conformity approval will still need to be structurally accepted on a site-by-site basis depending on the layout and loading of the component. Thermal properties and measures to prevent condensation will also require specific assessment depending on exposure, orientation etc.

Timber frame systems: Warranty requirements

'Conventional' timber frame open panel* systems made off-site under factory conditions. Such panel systems are required to be manufactured and erected on-site under quality assured systems to either structural timber association (STA) 'gold' or 'silver' level or approved under the BM TRADA 'Q Mark' approval system, or CATG – Frame Mark. Confirming in all cases that there is an ISO 9001 based quality control system in place for the materials supply, design and manufacture of the frame, and trained competent installers erect the frames. Alternatively, any off-site manufactured timber frame kit, system or wall panel that has been accepted via the Warranty System Acceptance process will be acceptable.

For a 'non-accredited' manufacturer who are not accredited with STA, BM TRADA or CATG, a current ISO9001 certificate and Innovation Team acceptance must be in place and structural design and calculations for each site for each building/house type must be endorsed by an Engineer (subject to plot number limitation)

*Open panel/Semi-open panel systems are defined as systems which may include the external breather membrane and sheathing board, insulation internally between the studs and a translucent VCL which is left unfixed in order that the connections between panels can be viewed upon inspection. This type of panel system should be based on conventional connection details (mechanically fixed inside the panel, both vertically and horizontally, not relying on skew fixings/plates/straps etc.)

Timber frame panels which arrive to site with additional elements e.g. external cladding or a non-translucent VCL will need to undergo our in house Warranty Acceptance process. Systems must be accepted before Warranty quote is offered. Requirements for quality control systems (STA/TRADA/CATG/ISO9001) are the same as for open-panel systems above.

Closed panel/enclosed panel systems should be assessed and accepted by the Warranty Innovations team prior to manufacture and before a Warranty quote applied for.

One off site assembled timber frame/traditional stick built open panel systems that do not have any QA procedures and are not STA or BM TRADA approved (as above) will need independent Engineer supervision and monitoring of the installation, erection and completion (sign off) of the system. The systems should be erected by trained, experienced timber frame erectors.

Where an independent Engineer is engaged to monitor the design, installation, erection and completion of the Timber Frame system, the Engineer must confirm, in writing prior to sign off, that the timber frame system has been installed:

- In accordance with the design and fixing specification.
- In accordance with the structural calculations.
- With all structural timbers appropriately preservative treated in accordance with BS 8417.

Off-site manufactured or 'one-off' timber frame kits that include Green Oak in the construction are not acceptable. See the 'External Walls - Timber Frame' section for further information.

Light gauge steel frame systems: Warranty requirements

Off-site manufactured systems, must be provided with Steel Construction Institute Stage 1 assessment as a minimum, and/or independent UKAS or equivalent third party system approval. Any external wall make up incorporating external cladding or where elements of the system cannot be inspected on site must be subject to independent third party certificate and/or Warranty Innovations Team review and acceptance. Further guidance can be found in the 'External Walls' section.

All light steel frame systems must be provided with a detailed structural appraisal and supporting calculations on a site by site basis. The materials used should be part of a documented supply chain process linked to a ISO 9001 Quality management system covering the manufactured of the panels. Evidence of a Quality management system certification should be made available, if requested, to the Warranty Surveyor.

Please note: where light steel frame ring beams or floor joists are used in ground floors these should be a minimum of 150mm above ground level and be galvanised to a minimum 450g/m². Alternately where sited between 150mm and ground level (or waterproofing layer of a flat roof, balcony or terrace) and the lowest steel or base rail cannot be guaranteed, (e.g. at localised areas for level access) the steel should be galvanised to a minimum 600g/m².

Provision of cavities to all framed structures

All timber and light steel frame external wall panels must be provided with a drained cavity between the cladding and the structural frame. In addition; the cavity will be required to be ventilated for timber framed external walls. The frame should also be protected by a suitable third party approved breather membrane. Breather membranes should be of minimum Class W2 zero leakage in accordance with BS EN 13859, higher Class W1 will be requested when used in areas of high exposure to wind driven rain or where rain penetration of the cladding is expected.

CE / UKCA marking

The UKCA marking is a new GB product marking that is to be used for goods being placed on the market in England, Wales and Scotland and it applies to most goods previously subject to the CE marking.

For 'Construction products', CE marked products will be accepted in UK until 30th June 2025.

All construction products in circulation in the England, Wales and Scotland markets must change their marking to UKCA mark by 1st July 2025.

There are separate requirements for the Northern Ireland market.

UK approved bodies

From 1st January 2021, UK notified bodies operating under the EU Construction Products Regulation and based in the UK were granted new UK 'approved body' status and listed in a new UK database.

Approved bodies are able to undertake conformity assessment activity for UK 'designated standards'. Where an approved body has undertaken the assessment, the manufacturer (or their authorised representative) must affix the UK marking. Rules around affixing the new UK marking will be equivalent to current CE marking.

For the Northern Ireland market, UK 'approved bodies' will be designated by the United Kingdom Accreditation Service (UKAS) and be allowed to assess the performance of construction products to EU harmonised standards. This will enable economic operators to use the CE marking with the UK (NI) indication and place their product on the Northern Ireland market.

These bodies are listed on the UK Market Conformity Assessment Body ('UKMCAB') database.

Modern methods of construction (MMC)

It is important to ensure that MMC, products or systems meet the same requirements as detailed in 'Suitability of products'.

Construction methods that cannot meet the requirements of this Technical Manual must be submitted for acceptance by the Warranty provider in advance of the Warranty application, at the design stage, well before commencement on-site.

MMC, products or systems that have third-party approval will still need to be structurally accepted on a site-by-site basis depending on the layout and loading of the component. Thermal properties and measures to prevent condensation will also require specific assessment depending on exposure, orientation etc.

Where the components of the Innovative MMC system cannot be inspected on site (e.g. closed panels or volumetric modules), the system should be subject to review by Innovations Team.

Modern Methods of Construction (MMC) are pre manufactured/off-site produced systems and components which are used in the construction industry, particularly for housing, as they potentially represent savings in time and materials, and provide higher standards of quality than more conventional methods of construction.

Key points to note are:

- Off-site assembly means quick erection times on-site and a quick, weather tight construction achieved.
- The accurate setting out of foundations etc. needs to be managed and may require pre-levelling checks to be completed prior to delivery of MMC systems to site.
- MMC, particularly volumetric modular systems and large panel systems, will require advanced planning of the site for access, off-loading, installation and possibly storage of systems.
- The construction, design and layout of a typical system is planned in advance, so last-minute changes have to be avoided by good project management and what is known as a 'design freeze', imposed in advance of production commencing in the factory.
- The quality of the final product will rely on accurate assembly on-site by factory-trained or authorised Specialist Contractors.
- Where on site zip-up works are required, it is expected that these works will be undertaken by suitability trained staff and overseen by a supervisor directly employed by the system manufacturer as a minimum.
- MMC takes advantage of standardised construction, and may not be adaptable for complex architectural or planning design requirements. Additional testing may be necessary to ensure standards for durability and weather tightness can be achieved e.g. incorporating flat roof drainage outlets through closed panel parapet extensions.
- The key to good quality MMC system is protection of building elements in transit, storage and during erection until the building receives final weather protection. Water trapped in closed-panel systems could damage both structure and insulation, therefore Quality Assurance is crucial at every stage of the off-site manufactured construction process.

Types of modern methods of construction (MMC)

The definition of MMC spans a range of approaches from, off-site, near site and on site pre manufacturing, process improvements and technology applications.

Some typical examples of MMC are defined below:

- Category 1 – Pre-manufactured (3D primary structural system) – Volumetric
- Category 2 – Pre-manufactured (2D primary structural system) – Panelised
- Category 3 – Pre-manufactured non-systemised primary structure) – Pre-manufactured structural members
- Innovative new components and systems new to the market that may or may not demonstrate compliance with a British or European standards.

The Modern Methods of Construction (MMC) categorisation as per Government definition framework.

Many MMC components are usually site-based assembled e.g. Insulated Concrete Formwork systems.

Volumetric - Pre manufactured 3D primary structural systems

Volumetric construction (also known as modular construction) involves the 'off-site' production of pre manufactured three-dimensional units. ISO 9001 accredited or equivalent quality controlled systems of production in the factory should be in place and expected.

Modules may be brought to site in a variety of different forms, ranging from a basic structural shell to one where all the internal and external finishes and services are already installed.

Volumetric construction can consist of timber frame (including engineered timber), light gauge steel, and concrete or composite constructions. External cladding may form part of the prefabricated system, with only localised on-site specialist sealing required.

Alternatively, traditional masonry cladding may need to be constructed; in this case, specific detailing for the support of claddings, cavity barriers and DPCs must be pre-agreed, Building Control compliant and checked by Site Managers.

Panelised- Pre manufactured 2D primary structural systems

Panelised systems are a systemised approach using flat panel units used for basic floor, wall, and roof structures (sometimes referred to as cassettes). These can comprise of varying materials and are produced in a factory environment. The panels are assembled on-site at the final workforce to produce a final three-dimensional structure. The most common approach is to use open panels, or frames, which consist of a skeletal structure only e.g. stick frame, with services, insulation, external cladding and internal finishes being installed on site.

More complex panels can be produced, these are typically referred to as closed panels. Closed panels involve more factory based fabrication and can include lining materials and insulation. These may also include services, windows, doors, internal wall finishes, and external claddings.

Hybrid

Again off-site manufactured, this combines both panelised and volumetric approaches, and typically volumetric units.

Sub-assemblies and components

This category covers factory-built sub-assemblies or components in an otherwise traditionally built structural form, typically schemes incorporating the use of floor or roof cassettes, precast concrete foundation assemblies, preformed service installations, and cladding systems etc.

Site-based systems

These are structural systems that fall outside the 'off-site manufactured' categories, such as Insulated Concrete Formwork (ICF). Only systems with independent third-party approval will meet the requirements of the Technical Manual. The acceptability of these systems relies heavily on the quality procedures in place for the installation of the system on-site, in accordance with third-party approval.

Innovative systems and products

These are 'Products and Systems' that are new to the market and do not demonstrate meeting the requirements of a relevant British or European standard and therefore not able to be CE/UKCA marked. These products and systems will need to be discussed with the Warranty provider at the earliest stage possible and before an offer of Warranty is given.

The Developer/Designer must provide evidence to confirm:

- Durability, Structural integrity, Water tightness, Sound Insulation, Thermal performance, Maintenance etc. of the product/system,
- The quality management systems in place for the construction/installation, and
- Evidence of a suitable third party product conformity certification (see notes in 'Suitability of products').
- Have agreement with the Warranty provider before it is integrated into the building works.

Where the components of the system cannot be inspected on site such as all off-site manufactured systems category 1 and all closed panel, or complex category 2 systems, these will require to be submitted to our Warranty Innovations Team for review and acceptance.

Suitability of MMC systems

(Please also refer to the requirements in 'Appendix C - Materials, Products, and Building Systems).

Building systems including 'off-site' manufactured systems should have independent third-party product approval, which must also recognise UK Building Regulation requirements. The Independent third party product/system approval must provide details of performance and testing carried out in the following areas to demonstrate acceptability to the Warranty provider:

- Structural integrity.
- Performance in fire situations.
- Resistance to water penetration (consider exposure rating of location), vapour permeability and dangerous substances.
- Safety in use.
- Acoustic characteristics.
- Thermal and movement characteristics.
- Compatibility of materials (interaction between components, structural or otherwise).
- Durability and longevity of materials (60 year service life where used in the structure or lesser period identified in the Service Life table in this section of the Technical Manual).
- Maintenance requirements and provisions.

Structural performance must be identified against appropriate BS EN standards. The Developer must provide structural calculations for each project on a case-by-case basis, and the design shall allow for robustness to disproportionate collapse.

Systems and components must be manufactured under a recognised quality management process. Systems and components might not have an overall full third-party product conformity approval but the individual components used must have the required full third party conformity certification. There must also be a current ISO 9001 Quality management system in place for the design, manufacture and erection of the system process (completed by a UKAS accredited organisation).

Where third-party product conformity certification is provided for a system or product, and the independent certification does not recognise our Warranty requirements, additional checks may be required to confirm the system is acceptable e.g. the need to provide a drained cavity behind some insulated cladding systems and to external cladding systems on timber and steel-framed systems. Supporting evidence of testing undertaken to prove the system may be asked for.

Durability and weather tightness are key aspects of the Warranty requirements, and the track record of the system will need to be established. Evidence of experience gained elsewhere, where environmental conditions may be significantly different, will need to be assessed, in comparison with conditions here in the UK.

Treatment of timber components will need to be assessed with regard to the species of timber used. The natural durability and the need for preservative treatment are dependent on the component's location in the construction and the Warranty requirement for durability. Treatment for insect attack in certain parts of the country will also be required. Certain European countries do not accept use of preservatives however for our Warranty requirements preservative treatment may be necessary unless evidence can be provided to demonstrate the timber species, heartwood used in the system is sufficiently durable without treatment for the position used in the building.

Detailing is critical in providing integrity to the building e.g. connections between a wall panel and a window unit. Supporting documentation must show the make-up of the tested system. When assessing projects, a particular design detail may not have been covered by the certification e.g. a balcony junction. This information must be made available at an early stage.

Certain components of a building have particular functions and may not be replaced by components that look similar but might structurally behave in a different manner. Similarly, a product with a third party assessment for a particular use may not be acceptable in a different form of construction.

The continuation of Quality Management Systems from manufacture to erection on-site must be demonstrated. The level of supervision of the systems on-site is critical to meet the Warranty requirements.

Structurally Insulated Panels (SIPs)

Structurally Insulated Panels (SIPs) are a form of composite panel. Only systems which hold full third party product conformity approval will meet the requirements of the Technical Manual. The third party accreditation must also cover how panels interconnect and not just cover a panel in isolation.

Where the SIP system is manufactured by a third party product approval certificate holder (the SIP Manufacturer) but is marketed under another name by 'another company': Where the openings are formed and erected by this 'another company' they must be authorised by the SIP Manufacturer/certificate holder to undertake such alterations, and the erection/installation of the panels.

Requirements for quality control systems (such as ISO9001) are the same as for open-panel systems.

Insulated concrete formwork (ICF)

Insulated concrete formwork (ICF) utilizes polystyrene (mainly) as a temporary formwork, with concrete poured into the formwork core at staged lifts to provide the structural 'wall' component to carry the loads of the building down to foundations, this can be both external and internal walls.

The insulation formwork (usually either expanded or extruded polystyrene (EPS or XPS)) is left in place after the concrete has cured to form a permanent integral part of the insulation of the building. An external weatherproof cladding system will be required as the ICF system alone is not proven to be resistant to weather.

For the purposes of this Technical Manual:

- The system proposed must have a current third party 'product approval'.
- ICF systems will be acceptable for a maximum of 3 storeys in height (including the ground floor level) and must be accompanied with a full Engineers design package. ICF systems may be accepted above the 3 storeys limit when third party independent Engineer is involved in pre-pour inspections and will provide final sign-off for the whole structure.
- Basements formed from ICF construction will not be acceptable. Alternative forms of Basement construction will be required and then only permitted if a CSSW qualified Waterproofing specialist takes responsibility for the design of the waterproofing to ensure the design meets the requirements of BS 8102. Further guidance can be found in the 'Basements' section of the Technical Manual.

Types of ICF structure

The formwork is usually one of the following four formats; Blocks, planks, panels, or composites with planks or panels where tie devices are used to secure the 'outer and inner' components together.

It is expected that all ICF type structures are to be erected by the ICF manufacturer's approved contractors that meet our Warranty conditions.

Weatherproof envelopes to ICF structures

Details of the type and construction of the external cladding system must be agreed with the Warranty Surveyor before installation:

- The provision for a horizontal damp proof course must be appropriate for the type of ICF system.
- The design must allow for effectively preventing water penetration at window/door openings. Using mastic as the only means of weather protection between the frame and the ICF will not suffice. The ICF manufacturer or the ICF association recommendations should be followed e.g. use of a compriband or similar third party product approved gasket DPC system around frame junctions. Particular attention should also be given to the joints between the windows and doors and the surrounding cladding system.
- The designer must provide details for prior approval of any lean-to/flat roof abutments, parapets or balcony constructions to determine how water penetration at these junctions to the inside of the building will be prevented.
- Claddings:
 - Masonry/stone cladding: a minimum 50mm cavity will be required and the wall tie fixings taken into the concrete core.
 - Timber cladding: a drained and vented 19mm minimum cavity will be

required. If open boarding, additional weather protection to the ICF may be required e.g. a render coat or a suitable breather membrane.

- External wall insulation systems (including a cladding finish) will only be acceptable if the system has a current third party 'product approval' stating it will provide a weather resistant cladding specifically for ICF structures and clearly state in which exposure zones it can be used. The method of fixing the EWI system may require both mechanical and bonded systems. Dot and dab adhesive will not suffice.
- Direct render cladding is only acceptable if it is a third party product approved render system which is accepted by the Warranty provider. Please refer to 'External Walls - Render' section of this Technical Manual. Note: The third party certification must also cover the maximum exposure rating for the direct applied render.

Installation

The ICF system must be installed by the ICF manufacturers recommended contractors. The height of lifts (stages of filling with concrete) must be properly controlled to avoid distortion to the formwork and honeycombing in the concrete core (due to incorrect placement). The installation of the formwork must ensure that after pouring the concrete core the requirements of the 'Tolerances' section of our Technical Manual will be met.

T 0800 183 1755 **E** enquiries@labcwarranty.co.uk **labcwarranty.co.uk**

 @LABC_Warranty  LABC Warranty  LABC Warranty

MD Insurance Services Ltd. is the scheme administrator for LABC Warranty and is authorised and regulated by the Financial Conduct Authority. Registered in England No: 3642459. **TS-11A-11.00-010223**

