

TECHNICAL UPDATE

Vertically stacked coupled window assemblies – warranty requirements



Introduction

We've recently witnessed a growing trend of window frames being of stacked or coupled vertically on site. From what we've seen in the past, this setup hasn't always considered the horizontal joint where the two window frames are connected and as a result we have been seeing various issues such as water ingress and structural integrity issues post completion.

We've renamed our sub-section in the upcoming 2024 Technical Manual to 'Additional Requirements for Vertically Stacked Coupled Window Assemblies'. This is to better reflect the type of window system covered and to align ourselves with the phrase 'coupled window assembly' which is used throughout the industry.

This article will highlight our updated requirements based on analysis we've carried out and consultations we've had with various industry professionals.

What is a vertically stacked coupled window assembly?

Vertically stacked coupled window assemblies for the purposes of Warranty, are more than one separate glazed panel and frame unit coupled together vertically in an external wall elevation. (Regardless of whether the assembly is contained within a single storey or extending to more stories)

The guidance within this article is limited to where coupled window assemblies are:

- Specified in low rise construction (Buildings of 5 storey or lower – including the ground floor level); and,
- Coupled in a vertical position.

The guidance within this article should be read in conjunction with the guidance in the 'External Windows and Doors' section of our Technical Manual.

General requirements

Vertically stacked coupled window assemblies must be part of a fully specified system and this must include details of dual sealed coupling joints, seals, fixings and other ancillary components.

Vertically stacked coupled window assemblies must be manufactured to BS 7412, BS 4873 or BS 6510. Timber coupled window and door assemblies are not acceptable for Warranty purposes.

Where vertically stacked coupled window assemblies are proposed, thermal breaks should be incorporated into the dual sealed coupling joints.

Vertically stacked coupled window assemblies need to be sealed at the edges and drained at the front to prevent water ingress at the edges.

TECHNICAL UPDATE

Vertically stacked coupled window assemblies – warranty requirements



Testing

Where any coupled window assemblies are proposed, they will require both off-site and on-site testing as detailed below.

Off-site testing

Coupled window assemblies require off-site testing to BS EN 14351-1 and this must be for the complete coupled window assembly (with the dual sealed coupling joint in place), not just individual units.

Vertically stacked coupled window assemblies with higher levels of performance will be required for locations exposed to high levels of driving rain and this should be detailed by the system manufacturer.

Please note: individual units with third party certification usually do not cover a coupled window assembly scenario.

On-site testing

Where vertically stacked coupled window assemblies are proposed, on-site testing of water penetrations to critical joints (such as dual sealed coupling joints) in accordance with CWCT test methods is required to check to site workmanship of the building envelope as constructed. Areas and method of testing is to be agreed with the Warranty Surveyor prior to construction commencing. See CWCT Technical Note 41 and 102 for guidance.

Minimum requirements for on-site testing may be increased for areas subject to extreme weather conditions, exposed locations or coastal locations. The testing may also be increased where bespoke jointing systems are proposed as part of the construction.

Dual sealed coupling joints

Where vertically stacked coupled window assemblies are specified, pre-fabricated dual sealed coupling joints should be used for creating a weather tight joint. A dual sealed coupling joints must include:

- Outer seals as the primary water barrier.
- Inner seals providing an air barrier and secondary water barriers. The air barrier must be fully continuous around the full perimeter of the window.
- A drained cavity to remove any water that by passes the outer seal. This should be detailed to prevent water entering parts of the structure which are not intended to becoming wet.

Inner seals within the coupling joint must be placed within the joint during the assembly operation and be suitable for the proposed detailing. Suitable inner seals include impregnated foam tapes or flexible polymer gaskets. Wet sealants must not be solely relied upon.

If sealants (internal or external) are inaccessible or not easy to replace, their service life should match the service life of the window system as a minimum.

TECHNICAL UPDATE

Vertically stacked coupled window assemblies – warranty requirements



All seals must be permanently flexible and resistant to weathering.

All external sealants must be easy to replace.

Window sills

Vertically stacked coupled window assemblies must incorporate a sill which projects from the wall by at least 25mm. The water drip must project the wall by at least 10mm.

Large glazed areas including vertically stacked coupled window assemblies will result in a rapid run off of rainfall across the surface area of the glazing in comparison to rainfall falling onto a masonry surface. This should be taken into account with the window system design to ensure rainwater is effectively discharged away from the building and does not impact on the weatherproof envelope.

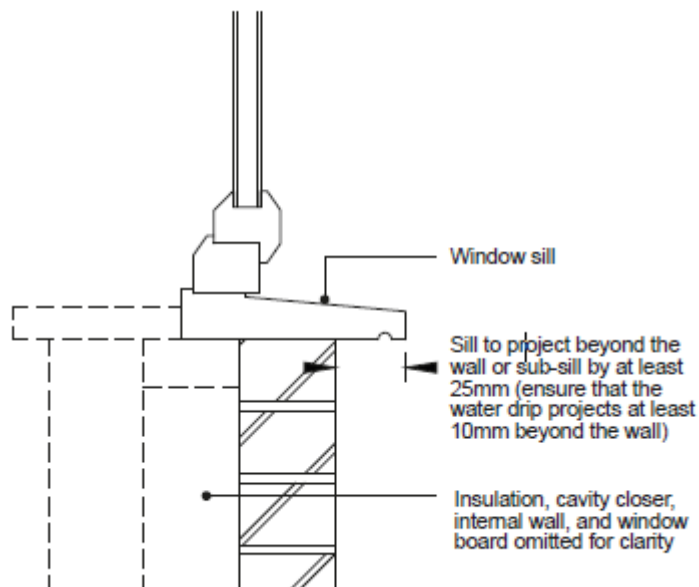

Structural integrity

Vertically stacked coupled window assemblies must be designed to be able to appropriately transfer its self-weight and imposed loads to the supporting structure.

The frame of the window needs to be able to resist the wind load in deflection, alternatively, the coupling joint needs to provide support and contribute to the overall stiffness of the system in resisting deflection.

Where the vertically stacked coupled window assembly extends to more than one window in both directions, the coupling joint in one direction must span the full width or height of the assembly and

TECHNICAL UPDATE

Vertically stacked coupled window assemblies – warranty requirements



will have to carry all the load at the junction(s) between the window frames. It will also have to support the ends of the joining components running in the transverse direction.

Accommodating movement

Movement gaps are required around all external windows and doors to accommodate differences in movement between the window and the surrounding wall construction as specified in our 'External Windows and Doors – General requirements' section of our Technical Manual.

However, where vertically stacked coupled window assemblies are specified, the gap sizes between the frame and wall construction may need to be greater and this should be specified by the system manufacturer.

Where a vertically stacked coupled window assembly extends across a horizontal movement joint (in a timber framed building with lightweight cladding for example), the design should allow for suitable jointing of the window assembly that will accommodate predicted structural movement whilst remaining weather tight and transferring loads to the building structure.

Vertically stacked couple window assemblies over 5 storeys

While the guidance within this article is predominantly for low rise developments, it should be noted for developments of 5 storeys or over, developers and designers should consult with our Major Projects team for further advice. For testing the following will be required:

- A minimum performance of 600 pascals water tightness will need to be achieved for vertically stacked coupled window and door assemblies.
- Vertically stacked coupled window assemblies will need to comply with CWCT Technical Note 95.

Every care was taken to ensure information in this article was correct at the time of writing (August 2023). Guidance provided does not replace the reader's professional judgement and any construction project should comply with the relevant building regulations or applicable technical standards. For the most up to date LABC Warranty technical guidance please refer to your risk management surveyor and the latest version of the [LABC Warranty Technical Manual](#).